

---

# OWNER'S MANUAL

---

## ELECTRIC CHAIN HOIST ER and NER SERIES

1/8 Ton through 5 Ton Capacity

Code, Lot and Serial Number

### **▲WARNING**

This equipment should not be installed, operated or maintained by any person who has not read and understood all the contents of this manual. Failure to read and comply with the contents of this manual can result in serious bodily injury or death, and/or property damage.

**HARRINGTON**  
HOISTS AND CRANES

## Table of Contents

<b>Section</b>	<b>Page Number</b>
1.0 Important Information and Warnings .....	4
1.1 Terms and Summary	
1.2 Warning Tags and Labels	
2.0 Technical Information.....	8
2.1 Specifications	
2.2 Dimensions	
3.0 Preoperational Procedures .....	12
3.1 Fill Gear Box with Oil	
3.2 Chain	
3.3 Mounting Location	
3.4 Mounting the Hoist	
3.5 Electrical Connections	
3.6 Preoperational Checks and Trial Operation	
4.0 Operation .....	19
4.1 Introduction	
4.2 Shall's and Shall Not's for Operation	
4.3 Hoist Controls	
5.0 Inspection .....	22
5.1 General	
5.2 Inspection Classification	
5.3 Frequent Inspection	
5.4 Periodic Inspection	
5.5 Occasionally Used Hoists	
5.6 Inspection Records	
5.7 Inspection Methods and Criteria	

<b>Section</b>	<b>Page Number</b>
6.0 Maintenance & Handling .....	29
6.1 Count/Hour Meter	
6.2 Lubrication	
6.3 Motor Brake	
6.4 Load Chain	
6.5 Friction Clutch and Mechanical Load Brake with Friction Clutch	
6.6 Storage	
6.7 Outdoor Installation	
7.0 Troubleshooting .....	35
8.0 Material Safety Data Sheets .....	38
8.1 ER Model Gear Box Oil	
8.2 NER Model Gear Box Oil	
8.3 (N)ER Model Load Chain Grease	
9.0 Warranty .....	51
10.0 Parts List .....	53

## 1.0 Important Information and Warnings

### 1.1 Terms and Summary

This manual provides important information for personnel involved with the installation, operation and maintenance of this product. Although you may be familiar with this or similar equipment, it is strongly recommended that you read this manual before installing, operating or maintaining the product.

#### Danger, Warning, Caution and Notice

Throughout this manual there are steps and procedures that can present hazardous situations. The following signal words are used to identify the degree or level of hazard seriousness.

**▲▲ DANGER** Danger indicates an imminently hazardous situation which, if not avoided, **will** result in **death or serious injury**, and property damage.

**▲▲ WARNING** Warning indicates an imminently hazardous situation which, if not avoided, **could** result in **death or serious injury**, and property damage.

**▲▲ CAUTION** Caution indicates a potentially hazardous situation which, if not avoided, **may** result **minor or moderate injury** or property damage.

**NOTICE** Notice is used to notify people of installation, operation, or maintenance information which is important but not directly hazard-related.

### ▲▲ CAUTION

These general instructions deal with the normal installation, operation, and maintenance situations encountered with the equipment described herein. The instructions should not be interpreted to anticipate every possible contingency or to anticipate the final system, crane, or configuration that uses this equipment. For systems using the equipment covered by this manual, the supplier and owner of the system are responsible for the system's compliance with all applicable industry standards, and with all applicable federal, state and local regulations/codes.

This manual includes instructions and parts information for a variety of hoist types. Therefore, all instructions and parts information may not apply to any one type or size of specific hoist. Disregard those portions of the instructions that do not apply.

Record your hoist's Code, Lot and Serial Number (see section 10) on the front cover of this manual for identification and future reference to avoid referring to the wrong manual for information or instructions on installation, operation, inspection, maintenance, or parts.

Use only Harrington authorized replacement parts in the service and maintenance of this hoist.

## **WARNING**

Equipment described herein is not designed for and **MUST NOT** be used for lifting, supporting, or transporting people, or for lifting or supporting loads over people.

Equipment described herein should not be used in conjunction with other equipment unless necessary and/or required safety devices applicable to the system, crane, or application are installed by the system designer, system manufacturer, crane manufacturer, installer, or user.

Modifications to upgrade, rerate, or otherwise alter this equipment shall be authorized only by the original equipment manufacturer.

Equipment described herein may be used in the design and manufacture of cranes or monorails. Additional equipment or devices may be required for the crane and monorail to comply with applicable crane design and safety standards. The crane designer, crane manufacturer, or user is responsible to furnish these additional items for compliance. Refer to ANSI/ASME B30.17, "Safety Standard for Top-Running Single Girder Cranes"; ANSI/ASME B30.2 "Safety Standard for Top-Running Double-Girder Cranes"; and ANSI/ASME B30.11 "Safety Standard for Underhung Cranes and Monorails".

If a below-the-hook lifting device or sling is used with a hoist, refer to ANSI/ASME B30.9, "Safety Standard for Slings" or ANSI/ASME B30.20, "Safety Standard for Below-the-Hook Lifting Devices".

Hoists and cranes, used to handle hot molten material may require additional equipment or devices. Refer to ANSI Z241.2, "Safety Requirements for Melting and Pouring of Metals in the Metalcasting Industry".

Electrical equipment described herein is designed and built in compliance with Harrington's interpretation of ANSI/NFPA 70, "National Electrical Code". The system designer, system manufacturer, crane designer, crane manufacturer, installer, or user is responsible to assure that the installation and associated wiring of these electrical components is in compliance with ANSI/NFPA 70, and all applicable Federal, State and Local Codes.

Failure to read and comply with any one of the limitations noted herein can result in serious bodily injury or death, and/or property damage.

## **DANGER**

### **HAZARDOUS VOLTAGES ARE PRESENT IN THE CONTROL BOX, OTHER ELECTRICAL COMPONENTS, AND CONNECTIONS BETWEEN THESE COMPONENTS.**

Before performing ANY mechanical or electrical maintenance on the equipment, de-energize (disconnect) the main switch supplying power to the equipment; and lock and tag the main switch in the de-energized position. Refer to ANSI Z244.1, "Personnel Protection – Lockout/Tagout of Energy Sources".

Only trained and competent personnel should inspect and repair this equipment.

## **NOTICE**

It is the responsibility of the owner/user to install, inspect, test, maintain, and operate a hoist in accordance with ANSI/ASME B30.16, "Safety Standard for Overhead Hoists", OSHA Regulations and ANSI/NFPA 70, National Electric Code. If the hoist is installed as part of a total lifting system, such as an overhead crane or monorail, it is also the responsibility of the owner/user to comply with the applicable ANSI/ASME B30 volume that addresses that type of equipment.

It is the responsibility of the owner/user to have all personnel that will install, inspect, test, maintain, and operate a hoist read the contents of this manual and applicable portions of ANSI/ASME B30.16, "Safety Standard for Overhead Hoists", OSHA Regulations and ANSI/NFPA 70, "National Electric Code". If the hoist is installed as part of a total lifting system, such as an overhead crane, the applicable ANSI/ASME B30 volume that addresses that type of equipment must also be read by all personnel.

If the hoist owner/user requires additional information, or if any information in the manual is not clear, contact Harrington or the distributor of the hoist. Do not install, inspect, test, maintain, or operate this hoist unless this information is fully understood.

A regular schedule of inspection of the hoist in accordance with the requirements of ANSI/ASME B30.16 should be established and records maintained.

## 1.2 Warning Tags and Labels

The warning tag illustrated below in [Figure 1-1](#) is supplied with each hoist shipped from the factory. If the tag is not attached to your hoist's pendant cord, order a tag from your dealer and install it. Read and obey all warnings attached to this hoist. Tag is not shown actual size.

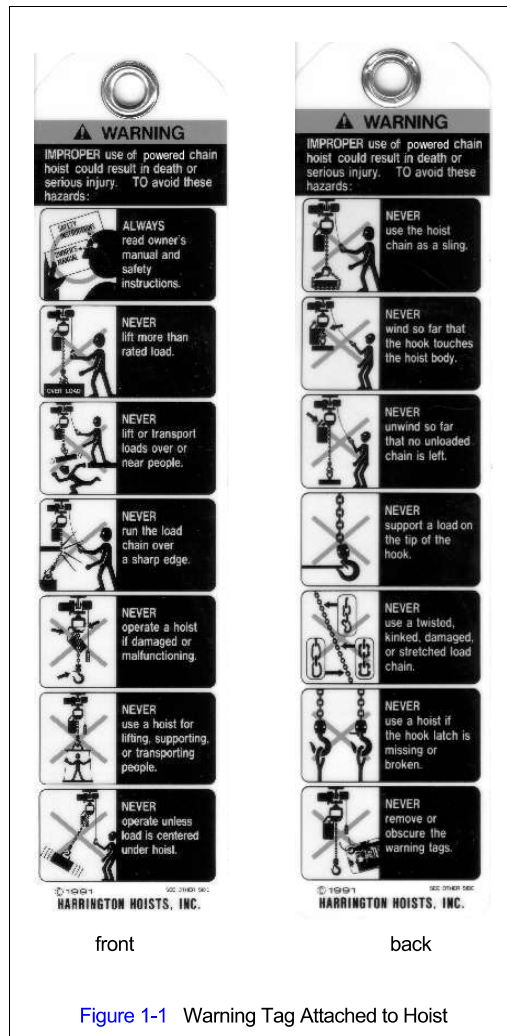

## 2.0 Technical Information

### 2.1 Specifications

#### 2.1.1 Product Code

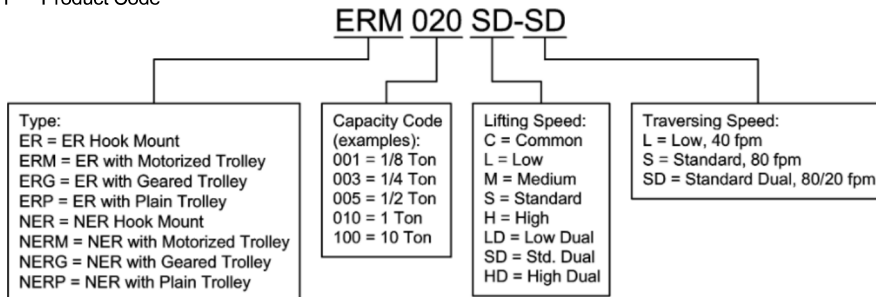

2.1.2 ER and NER Models - Harrington ER series hoist are available in two versions, the ER and NER. These two versions are equipped with different options as standard equipment. The NER has a friction clutch mechanism that provides over winding protection. The ER has a mechanical load brake/friction clutch combination and an electronic count/hour meter in the control circuit. Refer to [Figure 2-1](#) for the visual differences between the ER and NER.

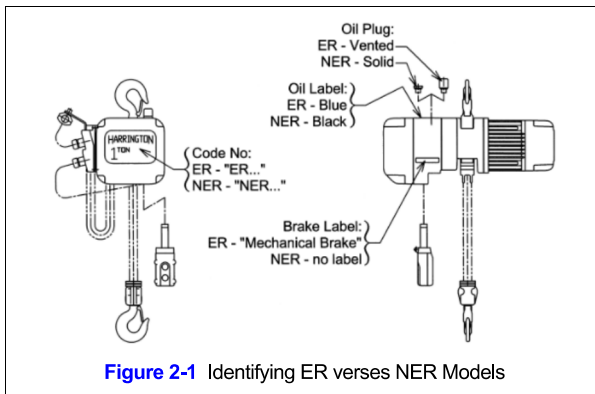

#### 2.1.3 Operating Conditions and Environment

Temperature range:  $-4^{\circ}$  to  $+104^{\circ}\text{F}$  ( $-20^{\circ}$  to  $+40^{\circ}\text{C}$ )  
 Humidity: 85% or less  
 Enclosure Rating: Hoist Meets IP 55, Pendant Meets IP65  
 Supply Voltage: Standard 208-230/460V-3-60, Optional 575V-3-60, Special Voltages Available

	Single Speed	Dual Speed
ASME Duty Classification:	H4	H4
Intermittent Duty Rating:	60% ED 360 starts per hour	40/20% ED 120/240 starts per hour
Short Time Duty Rating:	60 min.	30/10 min.

**Table 2-1 Hoist Specifications**

Capacity (Ton)	Code	Lifting Speed (ft/min)	Motor			Load Chain Wire Diameter (mm) x Chain Fall Lines	Load Sheave Pockets	Net Weight (lbs)	Weight for One Addnl. FT. of Lift (lbs)	
			Output (Hp)	Current Draw (amps)						
				208V or 230V	460V					
SINGLE SPEED	1/8	(N)ER001H	57	0.75	4.2	2.1	5.0 x 1	5	68	0.37
	1/4	(N)ER003S	39	0.75	4.2	2.1	5.0 x 1	5	68	0.37
	1/4	(N)ER003H	60	1.2	5.7	2.9	6.3 x 1	5	84	0.57
	1/2	(N)ER005L	15	0.75	4.2	2.1	6.3 x 1	4	70	0.57
	1/2	(N)ER005S	30	1.2	5.7	2.9	6.3 x 1	5	84	0.57
	1	(N)ER010L	16	1.2	5.7	2.9	8.0 x 1	4	90	0.93
	1	NER010M	24	1.9	7.3	3.7	8.0 x 1	4	110	0.93
	1	(N)ER010S	29	2.4	10.5	5.3	8.0 x 1	5	134	0.93
	1 1/2	(N)ER015S	20	2.4	10.5	5.3	10.0 x 1	4	152	1.5
	2	(N)ER020L	14	2.4	10.5	5.3	10.0 x 1	4	154	1.5
	2	NER020M	24	3.8	14.9	7.5	10.0 x 1	4	181	1.5
	2	(N)ER020S	28	4.7	18.3	9.2	10.0 x 1	5	240	1.5
	2 1/2	(N)ER025S	23	4.7	18.3	9.2	11.2 x 1	4	247	1.9
	3	NER030C	12	3.8	14.9	7.5	10.0 x 2	4	216	3.1
	3	(N)ER030L	16	4.7	18.3	9.2	12.5 x 1	4	256	2.3
	3	(N)ER030S	22	6.2	25.1	12.6	12.5 x 1	4	269	2.3
5	(N)ER050L	12	4.7	18.3	9.2	11.2 x 2	4	306	4.0	
DUAL SPEED	1/8	(N)ER001HD	58/19	0.6/0.2	2.9/2.4	1.5/1.2	5.0 x 1	5	79	0.37
	1/4	(N)ER003SD	29/10	0.6/0.2	2.9/2.4	1.5/1.2	5.0 x 1	5	79	0.37
	1/4	(N)ER003HD	60/20	1.2/0.4	5.7/5.1	2.9/2.6	6.3 x 1	5	104	0.57
	1/2	(N)ER005LD	14/5	0.6/0.2	2.9/2.4	1.5/1.2	6.3 x 1	4	84	0.57
	1/2	(N)ER005SD	30/10	1.2/0.4	5.7/5.1	2.9/2.6	6.3 x 1	5	104	0.57
	1	(N)ER010LD	14/5	1.2/0.4	5.7/5.1	2.9/2.6	8.0 x 1	4	108	0.93
	1	(N)ER010SD	29/10	2.4/0.8	9.1/5.7	4.6/2.9	8.0 x 1	5	152	0.93
	1 1/2	(N)ER015SD	20/7	2.4/0.8	9.1/5.7	4.6/2.9	10.0 x 1	4	165	1.5
	2	(N)ER020LD	15/5	2.4/0.8	9.1/5.7	4.6/2.9	10.0 x 1	4	168	1.5
	2	(N)ER020SD	29/10	4.7/1.6	19.6/9.4	9.8/4.7	10.0 x 1	5	284	1.5
	2 1/2	(N)ER025SD	23/8	4.7/1.6	19.6/9.4	9.8/4.7	11.2 x 1	4	295	1.9
	3	(N)ER030LD	17/6	4.7/1.6	19.6/9.4	9.8/4.7	12.5 x 1	4	300	2.3
3	(N)ER030SD	23/8	6.1/2.0	24.1/10.6	12.1/5.3	12.5 x 1	4	320	2.3	
5	(N)ER050LD	12/4	4.7/1.6	19.6/9.4	9.8/4.7	11.2 x 2	4	355	4.0	

## 2.2 Dimensions

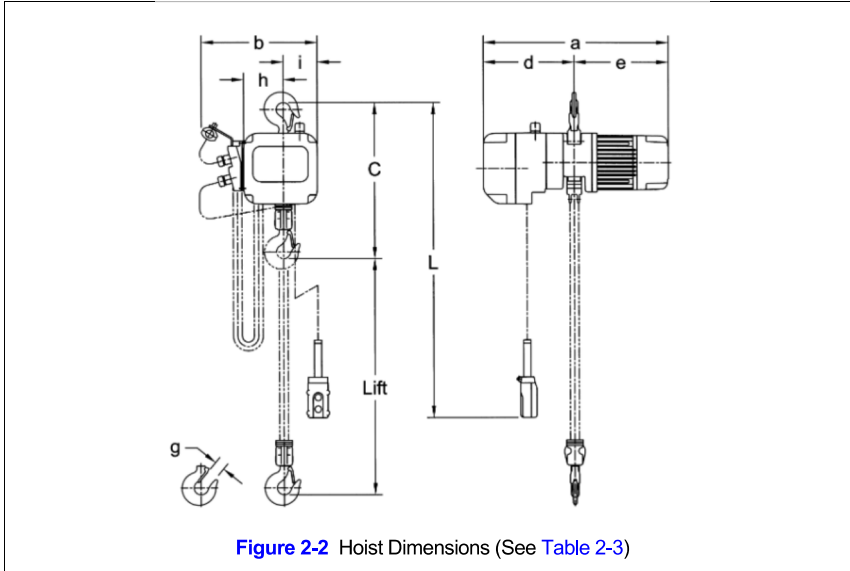

**Table 2-2** Hook Dimension\*

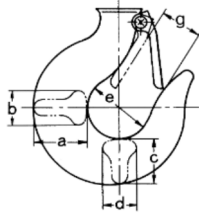

T = Top Hook  
 B = Bottom Hook  
 Units = inch

Capacity Code	Hook	a	b	c	d	e	g
001H, 003S, 003H, 005L, 005S	T	1.1	0.7	0.9	0.7	1.4	1.1
	B	1.1	0.7	0.9	0.7	1.4	0.9
010L, 010M, 010S	T & B	1.4	0.9	1.2	0.9	1.7	1.2
015S	T	1.9	1.1	1.6	1.1	2.0	1.5
	B	1.7	1.0	1.4	1.0	1.9	1.3
020S, 020M, 020L	T & B	1.9	1.1	1.6	1.1	2.0	1.5
025S	T	2.2	1.4	1.9	1.4	2.4	1.7
	B	2.0	1.2	1.7	1.2	2.1	1.6
030C, 030L, 030S	T & B	2.2	1.4	1.9	1.4	2.4	1.7
050L	T & B	2.6	1.7	2.2	1.7	2.5	1.8

\*Refer to Section 5.7 for inspection dimensions and limits.

**Table 2-3 Hoist Dimensions**

Hoist Code	Minimum Headroom: C (in)	L* (ft)	a (in)	b (in)	d (in)	e (in)	g (in)	h (in)	i (in)	
SINGLE SPEED	(N)ER001H	13.8	7.2	21.1	13.0	10.4	10.7	0.9	4.0	3.9
	(N)ER003S	13.8	7.2	21.1	13.0	10.4	10.7	0.9	4.0	3.9
	(N)ER003H	14.6	7.2	21.9	13.8	10.8	11.1	0.9	4.7	4.1
	(N)ER005L	14.0	7.2	21.1	13.0	10.4	10.7	0.9	4.0	3.9
	(N)ER005S	14.6	7.2	21.9	13.8	10.8	11.1	0.9	4.7	4.1
	(N)ER010L	16.1	7.2	21.9	13.8	10.8	11.1	1.2	4.7	4.1
	NER010M	16.1	7.2	23.2	13.8	10.6	12.6	1.2	4.7	4.1
	(N)ER010S	17.3	7.2	25.6	16.5	12.6	13.0	1.2	6.1	5.2
	(N)ER015S	19.9	7.2	25.6	16.5	12.6	13.0	1.3	6.1	5.2
	(N)ER020L	22.0	7.2	25.6	16.5	12.6	13.0	1.5	6.1	5.2
	NER020M	22.0	7.2	26.9	16.5	12.4	14.4	1.5	6.1	5.2
	(N)ER020S	24.0	8.2	30.9	18.9	15.5	15.5	1.5	7.2	6.5
	(N)ER025S	24.6	8.2	30.9	18.9	15.5	15.5	1.6	7.2	6.5
	NER030C	29.5	8.2	26.9	16.5	12.4	14.4	1.7	8.2	3.0
	(N)ER030L	26.0	8.2	30.9	18.9	15.5	15.5	1.7	7.2	6.5
	(N)ER030S	26.0	8.2	30.9	18.9	15.5	15.5	1.7	7.2	6.5
(N)ER050L	32.9	8.2	30.9	18.9	15.5	15.5	1.8	9.6	4.0	
DUAL SPEED	(N)ER001HD	13.8	7.2	22.2	13.0	10.4	11.9	0.9	4.0	3.9
	(N)ER003SD	13.8	7.2	22.2	13.0	10.4	11.9	0.9	4.0	3.9
	(N)ER003HD	14.6	7.2	23.2	13.8	10.6	12.6	0.9	4.7	4.1
	(N)ER005LD	14.0	7.2	22.2	13.0	10.4	11.9	0.9	4.0	3.9
	(N)ER005SD	14.6	7.2	23.2	13.8	10.6	12.6	0.9	4.7	4.1
	(N)ER010LD	16.3	7.2	23.2	13.8	10.6	12.6	1.2	4.7	4.1
	(N)ER010SD	17.3	7.2	26.9	16.5	12.4	14.4	1.2	6.1	5.2
	(N)ER015SD	20.5	7.2	26.9	16.5	12.4	14.4	1.3	6.1	5.2
	(N)ER020LD	22.6	7.2	26.9	16.5	12.4	14.4	1.5	6.1	5.2
	(N)ER020SD	27.0	8.2	32.2	18.9	15.5	16.8	1.5	7.2	6.5
	(N)ER025SD	27.0	8.2	32.2	18.9	15.5	16.8	1.6	7.2	6.5
	(N)ER030LD	28.5	8.2	32.2	18.9	15.5	16.8	1.7	7.2	6.5
	(N)ER030SD	28.5	8.2	32.2	18.9	15.5	16.8	1.7	7.2	6.5
(N)ER050LD	35.2	8.2	32.2	18.9	15.5	16.8	1.8	9.6	4.0	

\*The "L" dimensions are based on the standard lift of 10 feet.

## 3.0 Preoperational Procedures

### 3.1 Fill Gear Box with Oil

- 3.1.1 **CAUTION** The ER (with mechanical load brake/friction clutch) uses different gear oil than the NER (with friction clutch). DO NOT use any oil or quantity other than that listed below.
- 3.1.2 For a new hoist the correct quantity and type of oil is supplied with the hoist in separate container(s). Remove the fill plug from the top of the hoist and connect the flexible pour tube to the oil container. Pour in all of the oil from the separate container(s), then replace the fill plug.
- 3.1.3 Refer to [Section 6.2](#) when replacing the gear oil or checking the gear oil level.

Capacity Code	quarts	liters
001H, 003S, 005L	0.74	0.7
003H, 005S, 010L, 010M	1.06	1.0
010S, 015S, 020L, 020M, 030C	1.80	1.7
020S, 025S, 030L, 030S, 050L	3.17	3.0

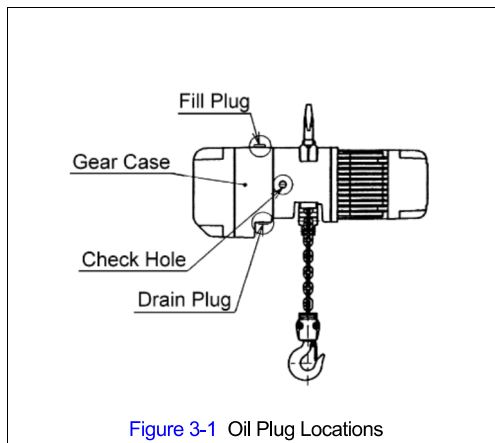

#### NER Gear Oil:

- Harrington standard: Bonnoc M260 (NIPPON OIL)
- Acceptable equivalent: Meropa 320 (TEXACO)
- Acceptable equivalent: Meropa 320 (CALTEX)

#### ER Gear Oil:

- Harrington standard: Antoil super B (NIPPON OIL)
- Acceptable equivalent: Meropa No.68 (TEXACO)

### 3.2 Chain

- 3.2.1 The quantity and location of the chain components including cushion rubbers, chain springs and striker plates depend on the hoist model, capacity and limits switches. Never operate the hoist with incorrect, missing or damaged chain components. Refer to the hoist's nameplate, [Table 3-2](#), and [Figures 3-2, 3-3, and 3-4](#) and ensure that all chain components are in the correct location and properly installed.
- 3.2.2 When the hoist is used without a chain container, the free end of the chain is attached to the hoist body as shown in [Figure 3-4](#). Connect the no load end of the chain to Chain Guide A with the End Wire or End Suspender provided. For 5 ton hoist, connect the no load end of the chain directly to Chain Guide A if Chain Guide A is notched to accept the chain. Make sure the chain remains free of twists and the chain Stopper is installed on the correct link. Refer to [Table 3-2](#) for proper placement of Stopper.

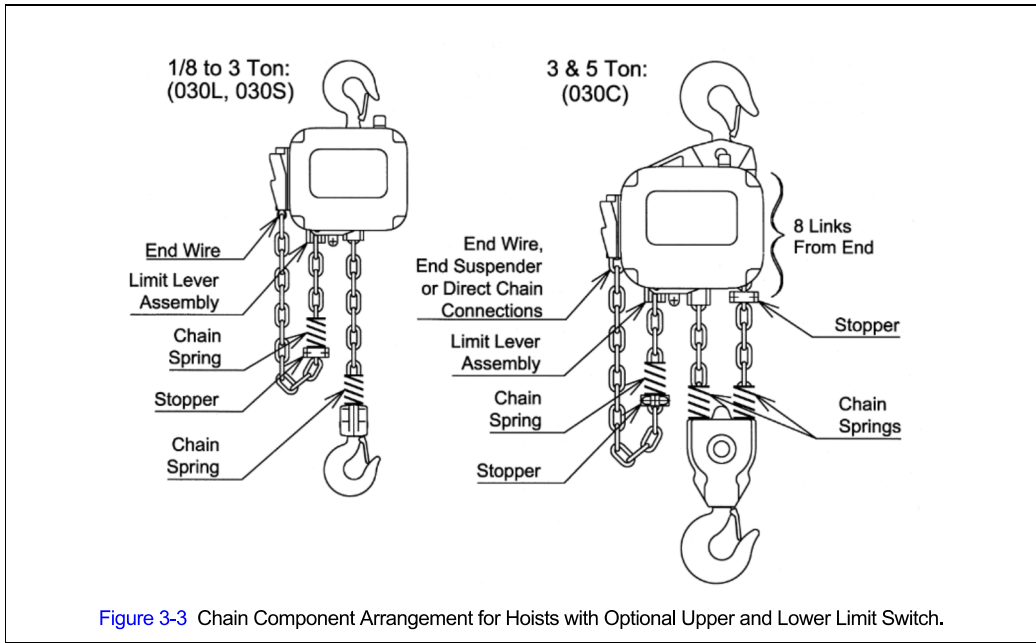
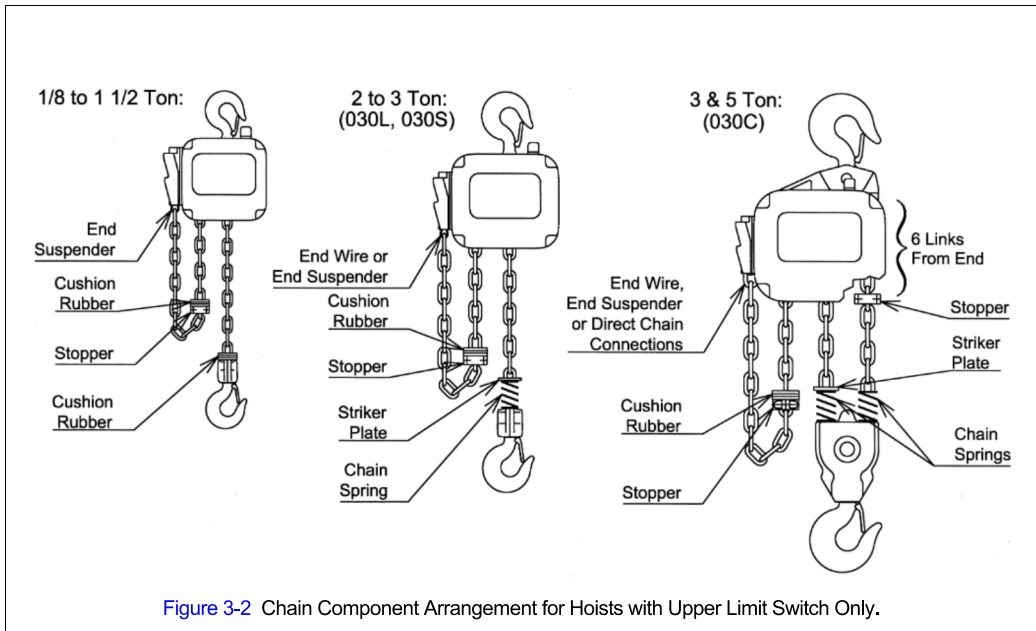

Table 3-2 Chain Stopper Placement		
Capacity Code	Without Chain Container	With Chain Container
001HD, dual speed with optional upper/lower limit switch	25 <sup>th</sup> link from the free end	3 <sup>rd</sup> link from the free end
001H, 003S, 003H, 005L, 005S, 010L, 010M, 010S, 015S, 020L, 020M, 030C	15 <sup>th</sup> link from the free end	3 <sup>rd</sup> link from the free end
020S, 025S, 030L, 030S, 050L	13 <sup>th</sup> link from the free end	3 <sup>rd</sup> link from the free end

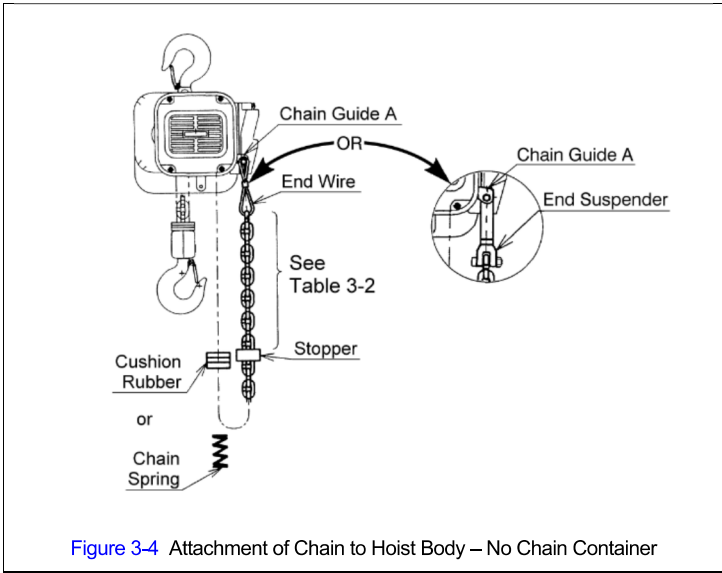

Figure 3-4 Attachment of Chain to Hoist Body – No Chain Container

- 3.2.3 When the optional canvas chain container is used, unfold it fully and install it on the hoist body as shown in Figure 3-5. In this case the free end of the chain is not attached to the hoist body and the chain stopper is installed on the third link from the free end. To place the chain into the chain container, feed the chain into the chain container beginning with the free end. Take care to avoid twisting or tangling the chain. NEVER put all the chain into the container at once. Lumped or twisted chain may:
- Upper Limit Switch Only - jam against the hoist body activating the friction clutch and potentially damaging the chain.
  - Upper and Lower Limit Switch (Optional) - activate the down limit switch and stop the hoist during lowering.
- 3.2.4 **⚠ CAUTION** Each chain container indicates the maximum length of the load chain that can be stored in the container. The amount of chain the container must hold is equal to the lift on the hoist. DO NOT use a chain container with a storage capacity less than the lift length on the hoist. If all of the chain can not be stored in the container, the limit switch will not operate properly.

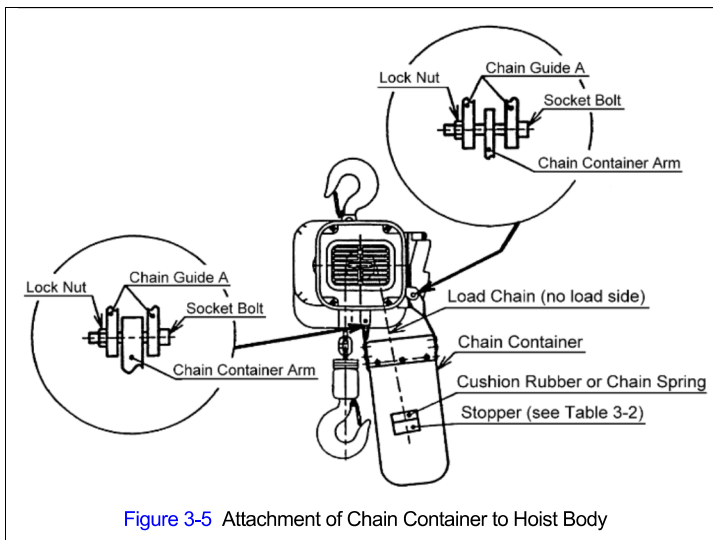

Figure 3-5 Attachment of Chain Container to Hoist Body

3.2.5 When using an optional steel chain container, refer to the assembly drawing and instructions provided with the container for correct assembly and attachment.

3.2.6 **⚠ WARNING** Verify that the load chain is not twisted or tangled prior to operating the hoist. Make sure the bottom hook on 3 and 5 Ton double fall models is not capsized. See Figures 3-6 and 3-7. Correct all chain irregularities before conducting the first hoist operation.

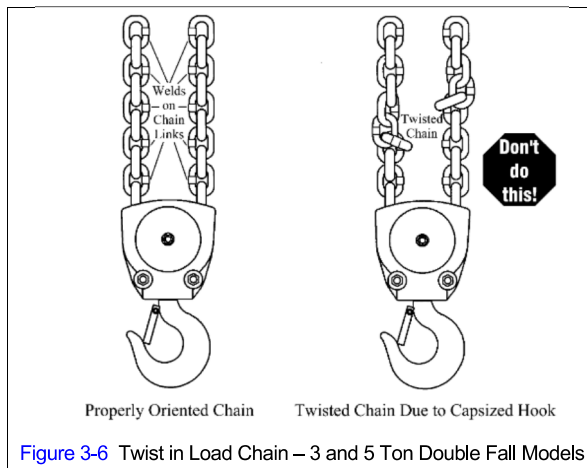

Figure 3-6 Twist in Load Chain – 3 and 5 Ton Double Fall Models

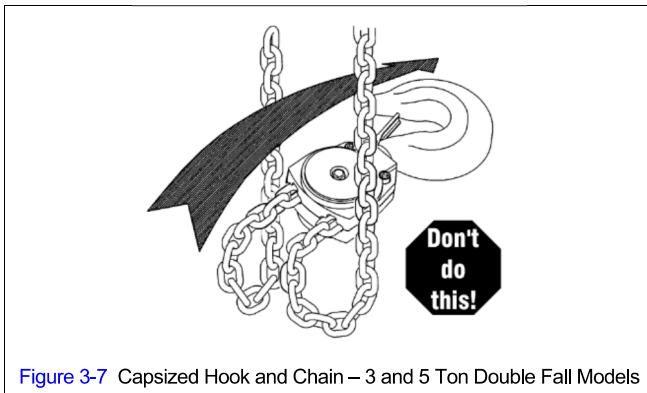

Figure 3-7 Capsized Hook and Chain – 3 and 5 Ton Double Fall Models

### 3.3 Mounting Location

- 3.3.1 **▲▲WARNING** Prior to mounting the hoist ensure that the suspension and the supporting structure are adequate to support the hoist and its loads. If necessary consult a professional that is qualified to evaluate the adequacy of the suspension location and its supporting structure.
- 3.3.2 **NOTICE** See [Section 6.7](#) for outdoor installation considerations.

### 3.4 Mounting the Hoist

- 3.4.1 Manual Trolley - Follow instructions in Owner's Manual provided with the trolley.
- 3.4.2 Motorized Trolley - Follow instructions in Owner's Manual provided with the trolley.
- 3.4.3 Hook Mounted to a Fixed Location - Attach the hoist's top hook to the fixed suspension point.
- 3.4.4 **▲▲WARNING** Ensure that the fixed suspension point rests on the center of the hook's saddle and that the hook's latch is engaged.

### 3.5 Electrical Connections

- 3.5.1 **▲▲CAUTION** Ensure that the voltage of the electric power supply is proper for the hoist or trolley.
- 3.5.2 **▲▲CAUTION** Do not apply variable speed control to the NER model hoist. Use the ER model for applications of variable speed control for hoists.
- 3.5.3 **▲▲DANGER** Before proceeding, ensure that the electrical supply for the hoist or trolley has been de-energized (disconnected). Lock out and tag out in accordance with ANSI Z244.1 "Personnel Protection -Lockout/Tagout of Energy Sources".
- 3.5.4 This instruction applies to installations where the hoist is installed hook mounted to a fixed suspension point or installed on a manual trolley. In this case the hoist is controlled by a pendant with two push buttons – one for raising and one for lowering. Refer to the appropriate trolley Owner's Manual if the hoist is installed on a motorized trolley.

#### Pendant Cord

The Pendant Cord connects to the hoist via a 5-pin (5P) Plug and Socket. Make this connection as follows:

- Refer to [Figure 3-8](#).
- Insert the 5P Plug into the 5P Socket on the hoist and hand tighten the Screw Coupling.
- Install the Cord Strain Relief Cable to the Cord Support on the bottom of the hoist.

### Power Supply Cable - Hoist Connection

The Power Supply Cable connects to the hoist via a 4-pin (4P) plug and socket. Make this connection as follows:

- Refer to [Figure 3-8](#).
- Insert the 4P plug of the Power Supply Cable into the 4P Socket on the hoist and hand tighten the screw coupling.
- Install the Cable Support Arm (pre-installed on the Power Supply Cable) on to the Socket Holder using the pre-installed Machine Screws and Lock Washers.
- Use care to avoid twisting or kinking the Power Supply Cable.

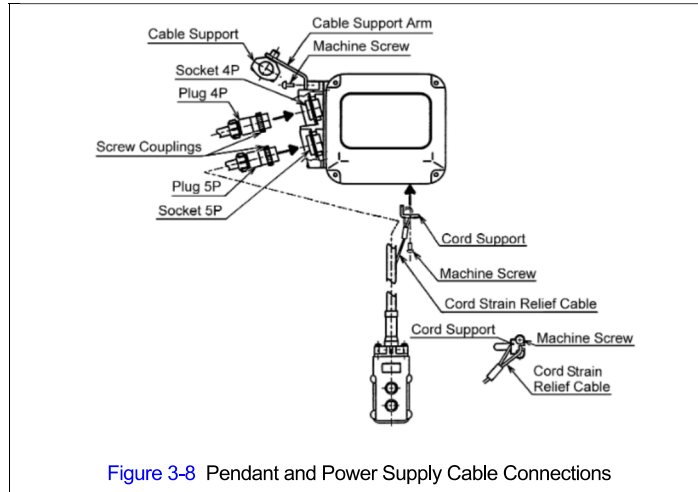

### Power Supply Cable - Installation

If the hoist is hook mounted to a fixed support ensure that the Power Supply Cable is properly installed and supported between the hoist and the electrical power supply.

If the hoist is installed on a manual trolley, then the Power Supply Cable must be installed along the beam that the trolley runs on. For curved beams a special cable suspension system will be needed, and this instruction does not apply. For straight beams install the Power Supply Cable as follows:

- Install a guide wire system parallel to the beam.
- For a manual trolley the guide wire should be positioned slightly outside the hoist's Cable Support as shown in [Figure 3-8](#).
- Use the Cable Trolleys supplied with the hoist to suspend the Power Supply Cable from the guide wire. Space the Cable Trolleys every 5 feet.

3.5.5 Connection to Electrical Power Source - The red, white, and black wires of the Power Supply Cable should be connected to an Electric Power Disconnect Switch or Circuit Breaker. This connection should be made so that the hoist is phased properly. Refer to [Section 3.6.11](#) for instructions on how to check for correct power supply phase connection.

3.5.6 Fuse/Breaker Capacity -The hoist's power supply should be equipped with overcurrent protection such as fuses, which should be selected for 110% to 120% of total listed full load amperage, and should be dual element time-delay fuses. Refer to the motor nameplate for the full load amperage draw.

- 3.5.7 **⚠ DANGER** Grounding - An improper or insufficient ground connection creates an electrical shock hazard when touching any part of the hoist or trolley. In the Power Supply Cable the ground wire will be either Green with Yellow stripe or solid Green. It should always be connected to a suitable ground connection. Do not paint the trolley wheel running surfaces of the beam as this can affect grounding.

### 3.6 Preoperational Checks and Trial Operation

- 3.6.1 **⚠ WARNING** Confirm the adequacy of the rated capacity for all slings, chains, wire ropes and all other lifting attachments before use. Inspect all load suspension members for damage prior to use and replace or repair all damaged parts.
- 3.6.2 **⚠ WARNING** Verify and correct all chain irregularities prior to operating the hoist. Refer to [Section 3.2](#).
- 3.6.3 Measure and record the "k" dimension of all hooks on hoist. See [Table 5-4](#) under [Section 5](#), "Inspection".
- 3.6.4 Record the hoist's Code, Lot and Serial Number (from the name plate on the hoist; see section 10) in the space provided on the cover of this manual.
- 3.6.5 Ensure that the hoist is properly installed to either a fixed point, or trolley, whichever applies.
- 3.6.6 If hoist is installed on a trolley, ensure that
- trolley is properly installed on the beam, and
  - stops for the trolley are correctly positioned and securely installed on the beam.
- 3.6.7 Ensure that all nuts, bolts and split pins (cotter pins) are sufficiently fastened.
- 3.6.8 Pull down on the Pendant and ensure that the Cord Strain Relief Cable takes the force, not the Pendant Cord.
- 3.6.9 **⚠ CAUTION** Check supply voltage before everyday use. If the voltage varies more than 10% of the rated value, electrical devices may not function normally.
- 3.6.10 Confirm proper operation.
- Before operating read and become familiar with [Section 4](#) - Operation.
  - Before operating ensure that the hoist (and trolley) meets the Inspection, Testing and Maintenance requirements of ANSI/ASME B30.16.
  - Before operating ensure that nothing will interfere with the full range of the hoist's (and trolley's) operation.
- 3.6.11 **⚠ WARNING** The hoist must be connected to the power source such that its direction of operation corresponds to the up-and-down commands issued from the pendant control; i.e. pushing the up button must cause the hoist to raise. If the hoist does not operate correctly, shut off and lockout /tagout the main power source to the hoist. Disconnect and switch any two of the three input power leads at the power source to correct the hoist's motor phasing.

## 4.0 Operation

### 4.1 Introduction

#### DANGER

DO NOT WALK UNDER A SUSPENDED LOAD

#### WARNING

HOIST OPERATORS SHALL BE REQUIRED TO READ THE OPERATION SECTION OF THIS MANUAL, THE WARNINGS CONTAINED IN THIS MANUAL, INSTRUCTION AND WARNING LABELS ON THE HOIST OR LIFTING SYSTEM, AND THE OPERATION SECTIONS OF ANSI/ASME B30.16 and ANSI/ASME B30.10. THE OPERATOR SHALL ALSO BE REQUIRED TO BE FAMILIAR WITH THE HOIST AND HOIST CONTROLS BEFORE BEING AUTHORIZED TO OPERATE THE HOIST OR LIFTING SYSTEM.

HOIST OPERATORS SHOULD BE TRAINED IN PROPER RIGGING PROCEDURES FOR THE ATTACHMENT OF LOADS TO THE HOIST HOOK.

HOIST OPERATORS SHOULD BE TRAINED TO BE AWARE OF POTENTIAL MALFUNCTIONS OF THE EQUIPMENT THAT REQUIRE ADJUSTMENT OR REPAIR, AND TO BE INSTRUCTED TO STOP OPERATION IF SUCH MALFUNCTIONS OCCUR, AND TO IMMEDIATELY ADVISE THEIR SUPERVISOR SO CORRECTIVE ACTION CAN BE TAKEN.

HOIST OPERATORS SHOULD HAVE NORMAL DEPTH PERCEPTION, FIELD OF VISION, REACTION TIME, MANUAL DEXTERITY, AND COORDINATION.

HOIST OPERATORS SHOULD **NOT** HAVE A HISTORY OF OR BE PRONE TO SEIZURES, LOSS OF PHYSICAL CONTROL, PHYSICAL DEFECTS, OR EMOTIONAL INSTABILITY THAT COULD RESULT IN ACTIONS OF THE OPERATOR BEING A HAZARD TO THE OPERATOR OR TO OTHERS.

HOIST OPERATORS SHOULD **NOT** OPERATE A HOIST OR LIFTING SYSTEM WHEN UNDER THE INFLUENCE OF ALCOHOL, DRUGS, OR MEDICATION.

OVERHEAD HOISTS ARE INTENDED ONLY FOR VERTICAL LIFTING SERVICE OF FREELY SUSPENDED UNGUIDED LOADS. DO **NOT** USE HOIST FOR LOADS THAT ARE NOT LIFTED VERTICALLY, LOADS THAT ARE NOT FREELY SUSPENDED, OR LOADS THAT ARE GUIDED.

#### NOTICE

- Read ANSI/ASME B30.16 and ANSI/ASME B30.10.
- Read the hoist manufacturer's Operating and Maintenance Instructions.
- Read all labels attached to equipment.

The operation of an overhead hoist involves more than activating the hoist's controls. Per the ANSI/ASME B30 standards, the use of an overhead hoist is subject to certain hazards that cannot be mitigated by engineered features, but only by the exercise of intelligence, care, common sense, and experience in anticipating the effects and results of activating the hoist's controls. Use this guidance in conjunction with other warnings, cautions, and notices in this manual to govern the operation and use of your overhead hoist.

## 4.2 Shall's and Shall Not's for Operation

### **WARNING**

Improper operation of a hoist can create a potentially hazardous situation which, if not avoided, could result in death or serious injury, and substantial property damage. To avoid such a potentially hazardous situation **THE OPERATOR SHALL:**

- **NOT** lift more than rated load for the hoist.
- **NOT** operate unless load is centered under hoist.
- **NOT** use damaged hoist or hoist that is not working properly.
- **NOT** use hoist with twisted, kinked, damaged, or worn chain.
- **NOT** use hoist if the bottom hook is capsized (double fall hoists - see [Section 3.2](#)).
- **NOT** use the hoist to lift, support, or transport people.
- **NOT** lift loads over people.
- **NOT** apply load unless load chain is properly seated in the load sheave (and idle sheave for hoist with two chain falls).
- **NOT** use the hoist in such a way that could result in shock or impact loads being applied to the hoist.
- **NOT** attempt to lengthen the load chain or repair damaged load chain.
- **NOT** operate hoist when it is restricted from forming a straight line from hook to hook in the direction of loading.
- **NOT** use load chain as a sling or wrap load chain around load.
- **NOT** apply the load to the tip of the hook or to the hook latch.
- **NOT** apply load if binding prevents equal loading on all load-supporting chains.
- **NOT** operate beyond the limits of the load chain travel.
- **NOT** operate hoist with missing/damaged chain springs, cushion rubbers, stoppers or striker plates.
- **NOT** leave load supported by the hoist unattended unless specific precautions have been taken.
- **NOT** allow the chain, or hook to be used as an electrical or welding ground.
- **NOT** allow the chain, or hook to be touched by a live welding electrode.
- **NOT** remove or obscure the warnings on the hoist.
- **NOT** operate a hoist on which the safety placards or decals are missing or illegible.
- Be familiar with operating controls, procedures, and warnings.
- Make sure the unit is securely attached to a suitable support before applying load.
- Make sure load slings or other approved single attachments are properly sized, rigged, and seated in the hook saddle.
- Take up slack carefully - make sure load is balanced and load-holding action is secure before continuing.
- Make sure all persons stay clear of the supported load.
- Protect the hoist's load chain from weld splatter or other damaging contaminants.
- Report malfunctions or unusual performances (including unusual noises) of the hoist and remove the hoist from service until the malfunction or unusual performance is resolved.
- Make sure hoist limit switches function properly.
- Warn personnel before lifting or moving a load.
- Warn personnel of an approaching load.

## **⚠ CAUTION**

Improper operation of a hoist can create a potentially hazardous situation which, if not avoided, could result in minor or moderate injury, or property damage. To avoid such a potentially hazardous situation **THE OPERATOR SHALL:**

- Maintain a firm footing or be otherwise secured when operating the hoist.
- Check brake function by tensioning the hoist prior to each lift operation.
- Use hook latches. Latches are to retain slings, chains, etc. under slack conditions only.
- Make sure the hook latches are closed and not supporting any parts of the load.
- Make sure the load is free to move and will clear all obstructions.
- Avoid swinging the load or hook.
- Make sure hook travel is in the same direction as shown on controls.
- Inspect the hoist regularly, replace damaged or worn parts, and keep appropriate records of maintenance.
- Use the hoist manufacturer's recommended parts when repairing the unit.
- Lubricate load chain per hoist manufacturer's recommendations.
- **NOT** use the hoist load limiting or warning device to measure load.
- **NOT** use limit switches as routine operating stops. They are emergency devices only.
- **NOT** allow your attention to be diverted from operating the hoist.
- **NOT** allow the hoist to be subjected to sharp contact with other hoists, structures, or objects through misuse.
- **NOT** adjust or repair the hoist unless qualified to perform such adjustments or repairs.

### 4.3 Hoist Controls

4.3.1 For hoists mounted to motorized trolleys follow the control instruction included in the trolley's Owner's Manual.

4.3.2 Single Speed Pendant Control – When using the pendant control depress the up button to raise the hoist or the down button to lower the hoist as shown in [Figure 4-1](#) below. To stop motion release the buttons.

4.3.3 Dual Speed Pendant Control – Pendant controls supplied with dual speed hoists have two step control buttons. For low speed depress the button to the first step and for high speed depress the button fully to the second step. Use the up button to raise the hoist or the down button to lower the hoist as shown in [Figure 4-1](#) below. To stop motion release the buttons.

4.3.4 **⚠ CAUTION** Make sure the motor completely stops before reversing direction.

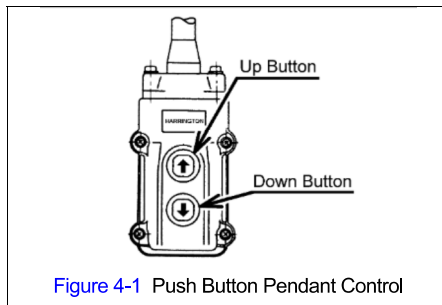

[Figure 4-1](#) Push Button Pendant Control

## 5.0 Inspection

### 5.1 General

- 5.1.1 The inspection procedure herein is based on ANSI/ASME B30.16. The following definitions are from ANSI/ASME B30.16 and pertain to the inspection procedure below.
- **Designated Person** – a person selected or assigned as being competent to perform the specific duties to which he/she is assigned.
  - **Qualified Person** – a person who, by possession of a recognized degree or certificate of professional standing, or who, by extensive knowledge, training, and experience, has successfully demonstrated the ability to solve or resolve problems relating to the subject matter and work.
  - **Normal Service** – that distributed service which involves operation with randomly distributed loads within the rated load limit, or uniform loads less than 65% of rated load for not more than 25% of the time.
  - **Heavy Service** – that service which involves operation within the rated load limit which exceeds normal service.
  - **Severe Service** – that service which involves normal or heavy service with abnormal operating conditions.

### 5.2 Inspection Classification

- 5.2.1 Initial Inspection – prior to initial use, all new, altered, or modified hoists shall be inspected by a designated person to ensure compliance with the applicable provisions of this manual.
- 5.2.2 Inspection Classification – the inspection procedure for hoists in regular service is divided into two general classifications based upon the intervals at which inspection should be performed. The intervals in turn are dependent upon the nature of the critical components of the hoist and the degree of their exposure to wear, deterioration, or malfunction. The two general classifications are herein designated as FREQUENT and PERIODIC, with respective intervals between inspections as defined below.
- 5.2.3 FREQUENT Inspection – visual examinations by the operator or other designated personnel with intervals per the following criteria:
- Normal service – monthly
  - Heavy service – weekly to monthly
  - Severe service – daily to weekly
  - Special or infrequent service – as recommended by a qualified person before and after each occurrence.
- 5.2.4 PERIODIC Inspection – visual inspection by a designated person with intervals per the following criteria:
- Normal service – yearly
  - Heavy service – semiannually
  - Severe service – quarterly
  - Special or infrequent service – as recommended by a qualified person before the first such occurrence and as directed by the qualified person for any subsequent occurrences.

### 5.3 Frequent Inspection

- 5.3.1 Inspections should be made on a FREQUENT basis in accordance with [Table 5-1](#), "Frequent Inspection." Included in these FREQUENT Inspections are observations made during operation for any defects or damage that might appear between Periodic Inspections. Evaluation and resolution of the results of FREQUENT Inspections shall be made by a designated person such that the hoist is maintained in safe working condition.

<b>Table 5-1 Frequent Inspection</b>
All functional operating mechanisms for maladjustment and unusual sounds.
Operation of limit switch and associated components
Hoist braking system for proper operation
Hooks in accordance with ANSI/ASME B30.10
Hook latch operation
Load chain in accordance with <a href="#">Section 5.7</a>
Load chain reeving for compliance with <a href="#">Section 3.2</a> and <a href="#">6.4</a>

### 5.4 Periodic Inspection

- 5.4.1 Inspections should be made on a PERIODIC basis in accordance with [Table 5-2](#), "Periodic Inspection." Evaluation and resolution of the results of PERIODIC Inspections shall be made by a designated person such that the hoist is maintained in safe working condition.
- 5.4.2 For inspections where load suspension parts of the hoist are disassembled, a load test per ANSI/ASME B30.16 must be performed on the hoist after it is re-assembled and prior to its return to service.

<b>Table 5-2 Periodic Inspection</b>
Requirements of frequent inspection.
Evidence of loose bolts, nuts, or rivets.
Evidence of worn, corroded, cracked, or distorted parts such as load blocks, suspension housing, chain attachments, clevises, yokes, suspension bolts, shafts, gears, bearings, pins and rollers.
Evidence of damage to hook retaining nuts or collars and pins, and welds or rivets used to secure the retaining members.
Evidence of damage or excessive wear of load and idler sheaves.
Evidence of excessive wear on motor or load brake.
Electrical apparatus for signs of pitting or any deterioration of visible controller contacts.
Evidence of damage of supporting structure or trolley, if used.
Function labels on pendant control stations for legibility.
Warning label properly attached to the hoist and legible (see <a href="#">Section 1.2</a> ).
End connections of load chain.

## 5.5 Occasionally Used Hoists

- 5.5.1 Hoists that are used infrequently shall be inspected as follows prior to placing in service:
- Hoist Idle More Than 1 Month, Less Than 1 Year: Inspect per FREQUENT Inspection criteria in [Section 5.3](#).
  - Hoist Idle More Than 1 Year: Inspect per PERIODIC Inspection criteria in [Section 5.4](#).

## 5.6 Inspection Records

- 5.6.1 Dated inspection reports and records should be maintained at time intervals corresponding to those that apply for the hoist's PERIODIC interval per [Section 5.2.4](#). These records should be stored where they are available to personnel involved with the inspection, maintenance, or operation of the hoist.
- 5.6.2 A long range chain inspection program should be established and should include records of examination of chains removed from service so a relationship can be established between visual observation and actual condition of the chain.

## 5.7 Inspection Methods and Criteria

- 5.7.1 This section covers the inspection of specific items. The list of items in this section is based on those listed in ANSI/ASME B30.16 for the Frequent and Periodic Inspection. In accordance with ANSI/ASME B30.16, these inspections are not intended to involve disassembly of the hoist. Rather, disassembly for further inspection would be required if frequent or periodic inspection results so indicate. Such disassembly and further inspection should only be performed by a qualified person trained in the disassembly and re-assembly of the hoist.

**Table 5-3 Hoist Inspection Methods and Criteria**

Item	Method	Criteria	Action
Functional operating mechanisms.	Visual, Auditory	Mechanisms should be properly adjusted and should not produce unusual sounds when operated.	Repair or replace as required.
Limit Switch	Function	Proper operation. Actuation of limit switch should stop hoist.	Repair or replace as required.
Limit Lever Assembly	Visual, Function	Lever should not be bent or significantly worn and should be able to move freely.	Replace.
Braking System Operation	Function	Braking distance with rated capacity should not exceed 3% of the lifting speed (approximately two chain links).	Repair or replace as required.
Hooks - Surface Condition	Visual	Should be free of significant rust, weld splatter, deep nicks, or gouges.	Replace.
Hooks - Fretting wear	Measure	The "u" and "t" dimensions should not be less than discard value listed in <a href="#">Table 5-4</a>	Replace.
Hooks - Stretch	Measure	The "k" dimension should not be greater than 1.15 times that measured and recorded at the time of purchase (See <a href="#">Section 3.6</a> ). If recorded "k" values are not available for hooks when new, use nominal "k" values from <a href="#">Table 5-4</a> .	Replace.
Hooks - Bent Shank or Neck	Visual	Shank and neck portions of hook should be free of deformations.	Replace.

**Table 5-3 Hoist Inspection Methods and Criteria**

Item	Method	Criteria	Action
Hooks - Yoke Assembly	Visual	Should be free of significant rust, weld splatter, nicks, gouges. Holes should not be elongated, fasteners should not be loose, and there should be no gap between mating parts.	Tighten or replace as required.
Hooks - Swivel Bearing	Visual, Function	Bearing parts and surfaces should not show significant wear, and should be free of dirt, grime and deformations. Hook should rotate freely with no roughness.	Clean/lubricate, or replace as required.
Hooks - Idle Sheave and Axle (Bottom Hook on Double Fall Hoist)	Visual, Function	Pockets of Idle Sheave should be free of significant wear. Idle Sheave surfaces should be free of nicks, gouges, dirt and grime. Bearing parts and surfaces of Idle Sheave and Axle should not show significant wear. Idle Sheave should rotate freely with no roughness or significant free play.	Clean/lubricate, or replace as required.
Hooks - Hook Latches	Visual, Function	Latch should not be deformed. Attachment of latch to hook should not be loose. Latch spring should not be missing and should not be weak. Latch movement should not be stiff - when depressed and released latch should snap smartly to its closed position.	Replace.
Load Chain - Surface Condition	Visual	Should be free of rust, nicks, gouges, dents and weld splatter. Links should not be deformed, and should not show signs of abrasion. Surfaces where links bear on one another should be free of significant wear.	Replace.
Load Chain - Pitch and Wire Diameter	Measure	The "P" dimension should not be greater than maximum value listed in <a href="#">Table 5-5</a> . The "d" dimension should not be less than minimum value listed in <a href="#">Table 5-5</a> .	Replace. Inspect Load Sheave (and Idle Sheave for double fall hoist).
Load Chain - Lubrication	Visual, Auditory	Entire surface of each chain link should be coated with lubricant and should be free of dirt and grime. Chain should not emit cracking noise when hoisting a load.	Clean/lubricate (see <a href="#">Section 6.0</a> ).
Load Chain - Reeving	Visual	Chain should be reeved properly through Load Sheave (and Idle Sheave for double fall hoist) - refer to <a href="#">Section 6.4</a> . Chain, Chain Springs, Cushion Rubbers, Striker Plates, and Stoppers should be installed properly - refer to <a href="#">Section 3.2</a> .	Reeve/Install chain properly.
Chain Container (optional)	Visual	Container should not be damaged. Brackets should not be deformed or missing.	Replace.
Housing and Mechanical Components	Visual, Auditory, Vibration, Function	Hoist components including load blocks, suspension housing, chain attachments, clevises, yokes, suspension bolts, shafts, gears, bearings, pins and rollers should be free of cracks, distortion, significant wear and corrosion. Evidence of same can be detected visually or via detection of unusual sounds or vibration during operation.	Replace.

**Table 5-3 Hoist Inspection Methods and Criteria**

Item	Method	Criteria	Action
Bolts, Nuts and Rivets	Visual, Check with Proper Tool	Bolts, nuts and rivets should not be loose.	Tighten or replace as required.
Motor Brake	Measure, Visual	Motor brake gap should be adjusted to the distance shown in <a href="#">Table 6-4</a> before measuring the brake wear. Brake lining dimension "A" should not be less than discard value listed in <a href="#">Table 5-6</a> . Refer to <a href="#">Section 6.3</a> for gaining access to motor brake and for adjustment and inspection procedures. Braking surfaces should be clean, free of grease/oil and should not be glazed.	Adjust, Repair or Replace as required.
Contactors Contacts	Visual	Contacts should be free of significant pitting or deterioration. On hoists equipped with Count/Hour Meter check the contactor cycles – refer to <a href="#">Section 6.1</a> .	Replace.
Load Sheave	Visual	Pockets of Load Sheave should be free of significant wear.	Replace.
Cushion Rubber	Visual	Should be free of significant deformation.	Replace.
Chain Springs	Visual	Chain springs should not be deformed or compressed.	Replace.
Pendant - Switches	Function	Depressing and releasing push-buttons should make and break contacts in switch contact block and result in corresponding electrical continuity or open circuit. Push-buttons should be interlocked either mechanically or electrically to prevent simultaneous energization of circuits for opposing motions (e.g. up and down).	Repair or replace as necessary.
Pendant - Housing	Visual	Pendant housing should be free of cracks and mating surfaces of parts should seal without gaps.	Replace.
Pendant - Wiring	Visual	Wire connections to switches in pendant should not be loose or damaged.	Tighten or repair
Pendant - Cord	Visual, Electrical Continuity	Surface of cord should be free from nicks, gouges, and abrasions. Each conductor in cord should have 100% electrical continuity even when cord is flexed back-and-forth. Pendant Cord Strain Relief Cable should absorb all of the load associated with forces applied to the pendant.	Replace.
Pendant - Labels	Visual	Labels denoting functions should be legible.	Replace.
Warning Labels	Visual	Warning Labels should be affixed to the hoist (see <a href="#">Section 1.2</a> ) and they should be legible.	Replace.
Hoist Capacity Label	Visual	The label that indicates the capacity of the hoist should be legible and securely attached to the hoist.	Replace.

**Table 5-4 Top Hook & Bottom Hook Dimensions**

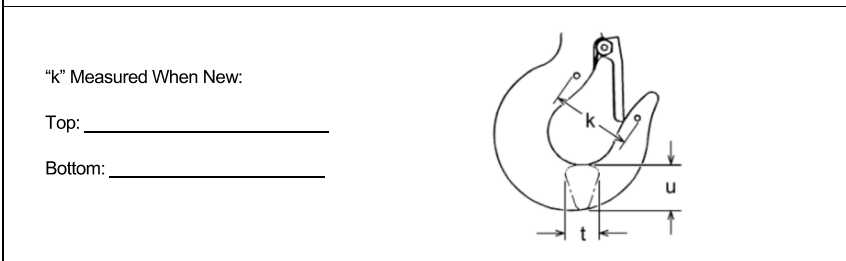

Capacity Code	Nominal "k" Dimension* inch (mm)	"u" Dimension inch (mm)		"t" Dimension inch (mm)	
		Standard	Discard	Standard	Discard
001H, 003S, 003H, 005L, 005S	1.65 (42)	0.93 (23.5)	0.83 (21)	0.69 (17.5)	0.63 (16)
010L, 010M, 010S	1.97 (50)	1.22 (31)	1.10 (28)	0.89 (22.5)	0.79 (20)
015S	2.36 (60)	1.44 (36.5)	1.30 (33)	1.04 (26.5)	0.94 (24)
020L, 020M, 020S	2.46 (62.5)	1.57 (40)	1.42 (36)	1.14 (29)	1.02 (26)
025S	2.72 (69)	43.5 (1.71)	1.54 (39)	1.24 (31.5)	1.10 (28)
030C, 030L, 030S	2.95 (75)	1.87 (47.5)	1.69 (43)	1.36 (34.5)	1.22 (31)
050L	3.27 (83)	2.20 (56)	1.97 (50)	1.67 (42.5)	1.50 (38)

\* These values are nominal since the dimension is not controlled to a tolerance. The "k" dimension should be measured when the hook is new - this becomes a reference measurement. Subsequent measurements are compared to this reference to make determinations about hook deformation/stretch. See Section 5.7, "Hooks - Stretch".

**Table 5-5 Chain Wear Dimensions**

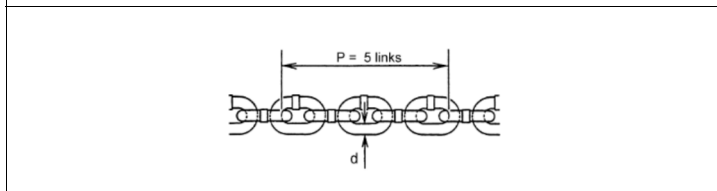

Capacity Code	"P" Dimension inch (mm)		"d" Dimension inch (mm)	
	Standard	Discard	Standard	Discard
001H, 003S,	2.97 (75.5)	3.02 (76.6)	0.22 (5.0)	0.18 (4.5)
003H, 005L, 005S	3.76 (95.5)	3.82 (96.9)	0.25 (6.3)	0.22 (5.7)
010L, 010M, 010S	4.76 (121.0)	4.91 (124.6)	0.31 (8.0)	0.28 (7.2)
015S, 020L, 020M, 020S, 030C	5.96 (151.5)	6.05 (153.8)	0.39 (10.0)	0.35 (9.0)
025S, 050L	6.75 (171.5)	6.85 (174.1)	0.44 (11.2)	0.40 (10.1)
030L, 030S	7.52 (191)	7.74 (196.7)	0.49 (12.5)	0.44 (11.3)

**Table 5-6 Motor Brake Wear Dimensions**

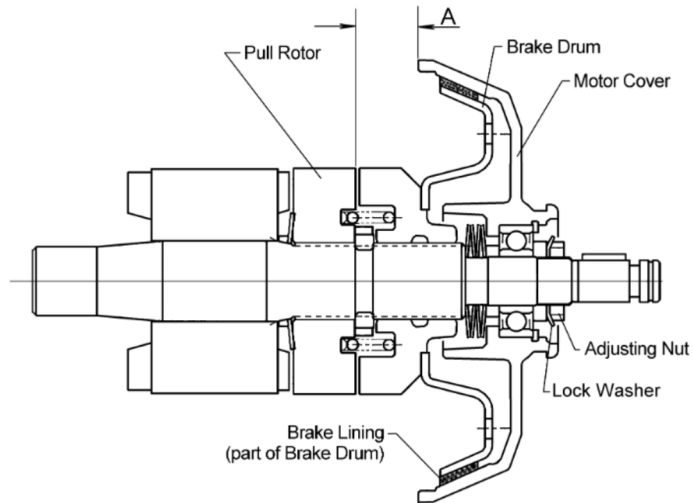

**NOTICE** Brake must be properly adjusted before measuring "A". See [Section 6.3](#)

Capacity Code	"A" Dimension - inch (mm)			
	Single Speed		Dual Speed	
	Standard	Discard	Standard	Discard
001H, 003S, 005L	0.67 (17)	0.61 (15.5)	0.67 (17)	0.61 (15.5)
003H, 005S, 010L, 010M	0.85 (21.5)	0.79 (20)	0.85 (21.5)	0.79 (20)
010S, 015S, 020L, 020M, 030C	0.89 (22.5)	0.83 (21)	1.06 (27)	1.00 (25.5)
020S, 025S, 030L, 030S, 050L	0.83 (21)	0.77 (19.5)	1.54 (39)	1.48 (37.5)

## 6.0 Maintenance and Handling

### 6.1 Count/Hour Meter

- 6.1.1 The Count/Hour (C/H) Meter located in on the electrical control panel records the hoist's on time and number of starts. To view the two values press the button on the C/H Meter one time. The display will first show an "H" and a 4 digit number which is the hoist's total on time (up and down) in hours. After 3 seconds the display will automatically change to a 6 digit number which is the number of starts of the hoist's down contactor. Refer to [Figure 6-1](#).

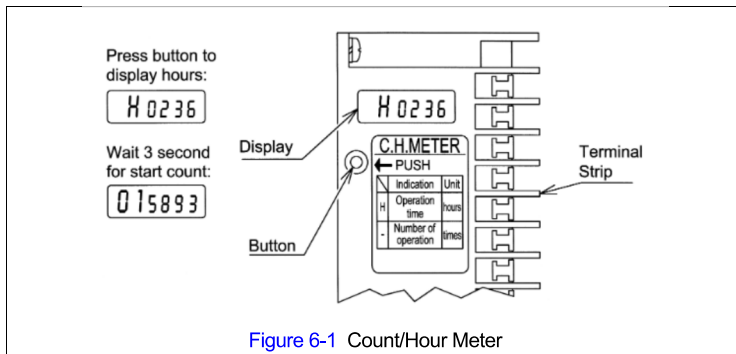

Figure 6-1 Count/Hour Meter

- 6.1.2 Contactor – The C/H Meter can be used in conjunction with the amount of jogging to estimate when the contactor(s) should be replaced. Jogging is when the pendant control buttons are pressed quickly and repetitively to move the hook in small increments. Refer to [Table 6-1](#).

Jogging During Normal Operation		Change Contactor After: (starts)
Rating	Approximate Jogging Frequency	
Low	Jogging is rare.	1,000,000
Medium	During 25% of operations/lifts.	500,000
High	During 50% or more of operations/lifts.	200,000

- 6.1.3 Gear Oil – The C/H Meter can be used in conjunction with the average load lifted by the hoist to estimate when the gear oil should be changed. Refer to [Table 6-2](#).

Loading During Normal Operation		Change Gear Oil After: (hours)
Rating	Average % of Rated Capacity	
Light	0 to 33%	360
Medium	33 to 67%	240
Heavy	67 to 100%	120

- 6.1.4 You are encouraged to use the Count/Hour Meter in conjunction with your experience with the hoist's application and usage to develop a history upon which to gage and fine tune your maintenance program for the hoist.

## 6.2 Lubrication

### 6.2.1 Load Chain

- For longer life, the load chain should be lubricated.
- The load chain lubrication should be accomplished after cleaning the load chain with an acid free cleaning solution.
- Apply Harrington lubricating grease (Part No. ER1BS1951) or an equivalent to industrial general lithium grease, NLGI No. 0, to the bearing surfaces of the load chain links as indicated by the shaded areas in [Figure 6-2](#). Also apply the grease to the areas of the load chain (shaded areas in [Figure 6-2](#)) that contact the load sheave. Insure that the grease is applied to the contact areas in the load sheave pockets.
- Machine or gear oil (grade ISO VG 46 or 68 oil or equivalent) may be used as an alternative lubricant but must be applied more frequently.

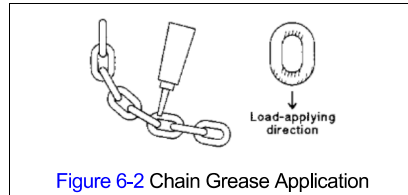

- The chain should be lubricated every 3 months (more frequently for heavier usage or severe conditions).
- For dusty environments, it is acceptable to substitute a dry lubricant.

### 6.2.2 Hooks and Suspension Components:

- Hooks - Bearings should be cleaned and lubricated at least once per year for normal usage. Clean and lubricate more frequently for heavier usage or severe conditions.
- Suspension Pins - Lubricate at least twice per year for normal usage; more frequently for heavier usage or severe conditions.

### 6.2.3 Gear Box:

- **⚠WARNING** Using an incorrect type/grade of gearbox oil or the wrong quantity of oil may prevent the friction clutch from working properly and may affect the ability of the hoist to hold the load. Refer to [Section 3.1](#) for the correct oil and quantity.
- The oil level can be checked using the oil check hole on the side of the hoist body shown in [Figure 3-1](#). The oil level should be in accordance with [Table 6-3](#) below.

Capacity Code	Oil Level (Hoist at level position)	
	Min	Max
Up to and including 010M	½" below bottom edge of check hole	Even with bottom edge of check hole.
010S and Up	1" below bottom edge of check hole	Even with bottom edge of check hole.

- Change gear oil at least once every 5 years. The oil should be changed more frequently depending on the hoist's usage and operating environment. Refer to [Section 6.1](#).
- Refer to [Figure 3-1](#) and [Table 3-1](#) to change the gear oil, remove both fill and drain plugs and allow the old oil drain completely. Replace the drain plug and refill the gear case with the correct quantity of new oil or until the oil level is within the range shown in [Table 6-3](#).
- **NOTICE** Dispose of the used oil in accordance with local regulations.

### 6.3 Motor Brake

6.3.1 To keep your hoist working in optimum condition and prevent possible down time, it is recommended to check your motor brake lining and adjustment at regular intervals.

6.3.2 Motor Brake Unit Removal - Adjustment and inspection of the motor brake requires removal of the motor brake unit from the hoist as an assembly.

- 1) **CAUTION** Before proceeding disconnect the power supply and make sure the hoist is unloaded. To keep the load chain from moving secure it by tying together the load and no-load sides directly under the hoist using a cord or wire.
- 2) Refer to [Figure 6-3](#).
- 3) Remove the four Fan Cover bolts (A), Fan Cover (B), Fan snap ring (C), and Fan washer (D).
- 4) Pull the Fan (E) off the motor shaft using a wheel puller if necessary.
- 5) Remove the four Motor Cover Assembly bolts (F) and carefully pull the motor brake unit (G) out of the hoist.

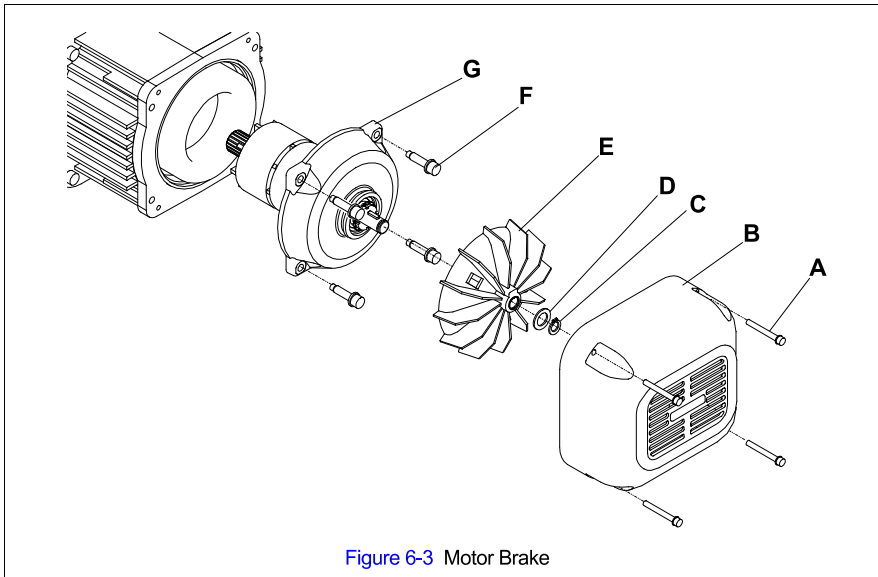

Figure 6-3 Motor Brake

6.3.3 Brake Gap (G) - The Brake Gap should be measured between the Brake Drum and Pull Rotor. Adjustment of the Brake Gap is accomplished by turning the Adjustment Nut in the center of the Motor Cover as shown in the figure with [Table 6-4](#). Do this as follows:

- 1) Bend the tab of the Lock Washer away from the Adjusting Nut so that the Adjusting Nut can be rotated.
- 2) Using a spanner wrench and a feeler gauge, rotate the Adjusting Nut to attain the proper Brake Gap per [Table 6-4](#).
- 3) After the Brake Gap is set, secure the Adjusting Nut by bending one of the tabs of the Lock Washer into a slot in the Adjusting Nut. If necessary rotate the Adjusting Nut clockwise (tightening) to line up the tab with the slot.
- 4) If the proper brake adjustment cannot be achieved, disassemble the motor brake and inspect all motor brake parts. Replace the Brake Drum and/or Motor Cover if necessary.

<b>Table 6-4 Motor Brake Gap</b>	
Capacity Code	Brake Gap (G) inch (mm)
001H, 003S, 005L, 003H, 005S, 010L, 010M, 010S, 015S, 020L, 020M, 030C	0.020 (0.5)
020S, 025S, 030L, 030S, 050L	0.032 (0.8)

6.3.4 Brake Lining Inspection –The brake lining is designed for a long life and should provide years of trouble-free service. If the brake lining is being inspected due to excessive load chain drift during operation (see [Section 5.7](#)), disassemble the motor brake and inspect all motor brake parts. Braking surfaces should be clean, free of grease/oil and should not be glazed. Replace the Brake Drum and/or Motor Cover if necessary. For normal inspections, the Brake Lining and Motor Cover wear should be measured as follows.

- 1) Adjust the Brake Gap per [Section 6.3.3](#) before measuring the Brake Lining and Motor Cover wear.
- 2) Refer to [Table 5-6](#).
- 3) Measure the distance "A" using calipers and a straight edge. Place the straight edge across the edge of the motor cover and measure from the straight edge to the face of the Pull Rotor.
- 4) Compare the measurement with the values listed in [Table 5-6](#). Replace the Brake Drum and/or Motor Cover if the "A" measurement is smaller than the discard limit.

- 6.3.5 Motor Brake Unit Installation - After the brake is properly adjusted and inspected, carefully replace the motor brake unit back into the hoist. Be sure to reseat the Motor Cover to motor frame surface using a small bead of liquid (hi-temperature) sealant. Refer to [Section 6.3.2](#) and reassemble the parts in reverse order of removal.

## 6.4 Load Chain

- 6.4.1 Lubrication and Cleaning – refer to [Section 6.2](#).

- 6.4.2 Load Chain Replacement:

- 1) **⚠ CAUTION** The hoist must be properly powered and operational in order to perform the following procedures.
- 2) **⚠ WARNING** Be certain that the replacement chain is obtained from Harrington and is the exact size, grade and construction as the original chain. The new load chain must have an odd number of links so that both its end links have the same orientation. If the load chain is being replaced due to damage or wear out, destroy the old chain to prevent its reuse.
- 3) **⚠ CAUTION** When replacing load chain, check for wear on mating parts, i.e. Load Sheave, Chain Guides and Idle Sheaves, and replace parts if necessary.
- 4) Remove all chain components including the Bottom Hook Set Assembly, Stoppers, Cushion Rubbers, Chain Springs, Striker Plates, Chain Pin and End Wire (or End Suspender) from the chain for reuse on new chain. Inspect and replace any damaged or worn parts.
- 5) Using a C-link, attach the new chain to the end link of the old chain on the no-load side. The end link of the new load chain should be connected so that the welded portions of the load chain's standing links are oriented to the outside as they pass over the sheave. Refer to [Figure 6-4](#).
- 6) Operate the hoist down to move the chain through the hoist body. Stop when a sufficient amount of new chain is accumulated on the load side.
- 7) Single fall hoists - Attach the chain components (step 4 above) to the chain. Refer to [Section 3.2](#) for the proper locations.
- 8) Double falls (030C, 050L) - Feed the end link on the load side of the new chain through the required chain components (step 4 above) and the bottom hook's Idle Sheave. Attach the remaining chain components to the chain referring to [Section 3.2](#) for the proper locations. Connect the end link to the top connection yoke with the chain pin, slotted nut and cotter pin. Ensure that chain remains free of twists. Refer to [Figures 3-6](#) and [3-7](#).
- 9) **⚠ WARNING** Make sure Stoppers, Cushion Rubbers, Chain Springs and Striker Plates are properly installed. Refer to [Section 3.2](#).
- 10) After installation has been completed, perform steps outlined in [Section 3.6](#) "Preoperational Checks and Trial Operation".

## 6.5 Friction Clutch and Mechanical Load Brake with Friction Clutch

- 6.5.1 Friction Clutch (NER Models) – If abnormal operation or slippage occurs do NOT attempt to disassemble or adjust the Friction Clutch. Replace the worn or malfunctioning Friction Clutch as an assembly with a new, factory adjusted part.
- 6.5.2 Mechanical Load Brake with Friction Clutch (ER Models) – If abnormal operation or slippage occurs do NOT attempt to disassemble or adjust the Mechanical Load Brake with Friction Clutch. Replace the worn or malfunctioning Mechanical Load Brake with Friction Clutch as an assembly with a new, factory adjusted part.

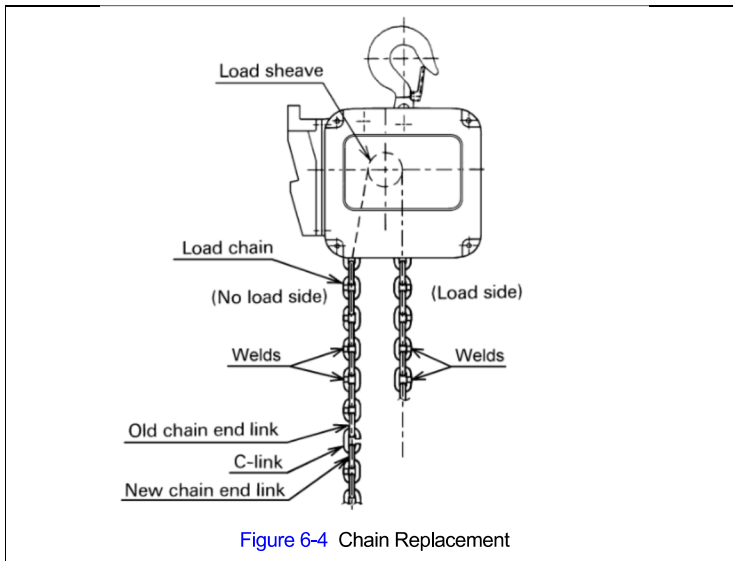

## 6.6 Storage

- 6.6.1 ER models with vented oil cap assemblies should be stored with the cap oriented up to prevent oil leakage.
- 6.6.2 The storage location should be clean and dry.

## 6.7 Outdoor Installation

- 6.7.1 For hoist installations that are outdoors, the hoist should be covered when not in use.
- 6.7.2 Possibility of corrosion on components of the hoist increases for installations where salt air and high humidity are present. Make frequent and regular inspections of the unit's condition and operation.

## 7.0 Troubleshooting

### **WARNING**

#### **HAZARDOUS VOLTAGES ARE PRESENT IN THE HOIST AND IN CONNECTIONS BETWEEN COMPONENTS.**

Before performing ANY troubleshooting on the equipment, de-energize the supply of electricity to the equipment, and lock and tag the supply device in the de-energized position. Refer to ANSI Z244.1, "Personnel Protection - Lockout/Tagout of Energy Sources."

Only Trained and competent personnel should inspect and repair this equipment.

**Table 7-1 Troubleshooting Guide**

Symptom	Cause	Remedy
Hoist moving in wrong direction	Power supply reversed phased	Switch 2 of the 3 power supply cord wires at the power source.
	Improper electrical connections	Refer to wiring diagram and check all connections.
Hoist will not operate	Loss of power	Check circuit breakers, switches, fuses and connections on power lines/cable.
	Wrong voltage or frequency	Check voltage and frequency of power supply against the rating on the nameplate of the motor.
	Hoist overload	Reduce load to within rated capacity of hoist.
	Motor overheated and thermal overload protector has tripped	See Trouble Shooting Problem "Motor or brake overheating".
	Improper, loose, or broken wire in hoist electrical system	Shut off power supply, check wiring connections on hoist control panel and inside push-button pendant.
	Brake does not release	Check motor brake adjustment for proper clearance.
	Faulty magnetic contactor	Check coil for open or short circuit. Check all connections in the control circuit. Check for open contactors. Replace as needed.
	Defect in control transformer	Check transformer coil for signs of overheating. Disconnect transformer and check for open winding.
Motor burned out	Replace motor frame/stator, shaft/rotor, and any other damaged parts.	

**Table 7-1 Troubleshooting Guide**

Symptom	Cause	Remedy
Hoist lifts but will not lower	Down circuit open	Check circuit for loose connections. Check down side of limit switch for malfunction.
	Broken conductor in pendant cord	Check the continuity for each conductor in the cable. If one is broken, replace entire cable.
	Faulty magnetic contactors	Check coils for open or short circuit. Check all connections on motor circuit. Check for burned contacts. Replace as needed.
	Faulty switch in pendant	Check electrical continuity. Check electrical connections. Replace or repair as needed.
Hoist lowers but will not lift	Hoist overloaded	Reduce load to within rated capacity of hoist.
	Low voltage in hoist's power supply	Determine cause of low voltage and bring to within plus or minus 10% of the voltage specified on the motor nameplate. The voltage should be measured at the hoist contactor.
	Up circuit open	Check circuit for loose connections. Check up side of limit switch for malfunction.
	Broken conductor in pendant cord	Check the continuity of each conductor in the cable. If one is broken, replace entire cable.
	Faulty magnetic contactor	Check coils for open or short circuit. Check all connections on motor circuit. Check for burned contacts. Replace as needed.
	Faulty switch in pendant	Check electrical continuity. Check electrical connections. Replace or repair as needed.
	Faulty friction clutch	Replace.
Hoist will not lift rated load or does not have the proper lifting speed	Hoist overloaded	Reduce load to within rated capacity.
	Low voltage in hoist's power supply	Determine cause of low voltage and bring to within plus or minus 10% of voltage specified on the motor nameplate. The voltage should be measured at the hoist contactor.
	Brake drags	Check motor brake adjustment for proper clearance.
	Faulty friction clutch	Replace.
Load drifts excessively when hoist is stopped	Motor brake not holding	Clean and inspect brake lining. Check brake adjustment for proper clearance.
	Mechanical Load brake not holding (ER only)	Replace as needed. (ER only, NER has no load brake.)

**Table 7-1 Troubleshooting Guide**

<b>Symptom</b>	<b>Cause</b>	<b>Remedy</b>
Motor or brake overheating	Excessive load	Reduce load to within rated capacity of hoist.
	Excessive duty cycle	Reduce frequency of lifts.
	Wrong voltage or frequency	Check voltage and frequency of power supply against the rating on the nameplate on the motor.
	Brake drags	Check brake adjustment for proper clearance.
	Extreme external heating	Above an ambient temperature of 140°F, the frequency of hoist operation must be reduced to avoid overheating of the motor. Special provisions should be made to ventilate the hoist or otherwise shield it from the heat.
Hoist operates intermittently	Collectors making poor contact	Check movement of spring loaded arm, weak spring, connections, and shoe. Replace as needed.
	Contactors contacts arcing	Check for burned contacts. Replace as needed.
	Loose connection in circuit	Check all wires and terminals for bad connections. Replace as needed.
	Broken conductor in Pendant Cord	Check for intermittent continuity in each conductor the Pendant Cord. Replace entire Pendant Cord if continuity is not constant.

## 8.0 Material Safety Data Sheets

### NOTICE

The ER and NER hoists are shipped new with the oil for the gear box and the grease for the load chain in separate container(s). In compliance with OSHA regulations, Material Safety Data Sheets (MSDS) have been provided for the gear oil that is provided in this separate container. The ER (with mechanical load brake/friction clutch) uses different gear oil than the NER (with friction clutch). Identify the correct model (refer to [Section 2.1](#)) before using the MSDS's below.

### 8.1 ER Model Gear Box Oil Material Safety Data Sheet (MSDS)

Effective date: June 9, 1998		MSDS No. 414005	
SECTION I CHEMICAL PRODUCT AND COMPANY IDENTIFICATION			
COMPANY IDENTIFICATION		NIPPON OIL COMPANY, LTD. 3-12, Nishi Shimbashi 1-chome, Minato-ku, Tokyo, 105-8412, Japan	
EMERGENCY TELEPHONE NUMBER:		+81-3-3502-9156	
TELEPHONE NUMBER FOR INFORMATION:		+81-3-3502-1111	
FAX NUMBER FOR INFORMATION:		+81-3-3502-3364	
PRODUCT NAME:		ANTOIL SUPER B	
PRODUCT USE:		Common lubricating oil for tractors	
SECTION II COMPOSITION/INFORMATION ON INGREDIENTS			
COMPOSITION			
<u>Components</u>	<u>Amount (%)</u>	<u>Limit</u>	
Highly refined petroleum oil	>92	5mg/m <sup>3</sup> TWA-OSHA (Mineral Oil Mist #1) 5 mg/m <sup>3</sup> TWA-ACGIH (Mineral Oil Mist #1)	
Additives	>8		
Anti-foam additives			
Detergents-dispersants			
Oxidation inhibitors			
<u>Hazardous Information</u>			
Product is non-hazardous. (1910, 1200 OSHA)			
#1 Highly refined petroleum oil, by definition, is considered hazardous according OSHA. Because it carries the Threshold Limit Value (TLV) for mineral oil mist.			

<b>SECTION III HAZARDS IDENTIFICATION</b>	
<b>EMERGENCY OVERVIEW</b>	
Warning statement: <p style="margin-left: 40px;">Caution! Prolonged or repeated contact with skin may cause irritation in some cases.</p>	
Precautionary Measures: <p style="margin-left: 40px;">Avoid breathing vapor and mist. Keep container closed.</p> <p style="margin-left: 40px;">Avoid contact with eyes, skin, and clothing.</p> <p style="margin-left: 40px;">Wash thoroughly after handling. Keep away from heat.</p>	
Potential health effect: <p style="margin-left: 40px;">Eyes: May cause minor irritation.</p> <p style="margin-left: 40px;">Skin: May cause minimal skin irritation.</p> <p style="margin-left: 40px;">Inhalation: Vapor or mist, in excess of permissible concentrations, or in unusually high concentrations generated from spraying, heating the material, or as from exposure in poorly ventilated areas or confined spaces, may cause irritation of the nose and throat, headache, nausea and drowsiness.</p> <p style="margin-left: 40px;">Ingestion: May cause abdominal discomfort, nausea or diarrhea.</p> <p style="margin-left: 40px;">Sensitization properties: Unknown</p> <p style="margin-left: 40px;">Chronic Properties: If prolonged exposure occurs, nausea, headache, diarrhea, and physical discomfort.</p> <p style="margin-left: 40px;">Other remarks: None</p>	
<b>SECTION IV FIRST AID MEASURES</b>	
<p style="margin-left: 40px;">Eyes: Flush immediately with water for at least 15 minutes. Get immediate medical attention.</p> <p style="margin-left: 40px;">Skin: Wash with soap and water. Get medical attention if irritation develops. Launder contaminated clothing before reuse.</p> <p style="margin-left: 40px;">Inhalation: Remove exposed person to fresh air if adverse effects are observed.</p> <p style="margin-left: 40px;">Ingestion: Do not make person vomit unless directed to do so by medical personnel.</p> <p style="margin-left: 40px;">Note to physician: Treat symptomatically.</p>	
<b>SECTION V FIRE FIGHTING MEASURES</b>	
<p style="margin-left: 40px;">Flash point (Typical), °C: 234(COC)</p> <p style="margin-left: 40px;">Autoignition tempt., °C: Not Determined</p> <p style="margin-left: 40px;">Flammability limits: Not Determined</p> <p style="margin-left: 40px;">Extinguishing media: Carbon Dioxide (CO<sub>2</sub>), dry chemical, or foam.</p> <p style="margin-left: 40px;">Special fire fighting procedures: Recommend wearing self-contained breathing apparatus. Water may cause splattering. Material will float on water.</p> <p style="margin-left: 40px;">Unusual fire &amp; explosion hazards: Toxic fumes, gases or vapors may evolve on burning.</p> <p style="margin-left: 40px;">Autoignition temperature: Not determined.</p> <p style="margin-left: 40px;">Explosion date: Material does not have explosive properties.</p>	

SECTION VI ACCIDENTAL RELEASE MEASURES		
Procedures in Case of Accidental Release, Breakage, or Leakage: Stop the source of the leak or release. Clean up releases as soon as possible. Contain liquid to prevent further contamination of soil, surface water or groundwater. Clean up small spills using appropriate techniques such as absorbent materials or pumping. Where feasible and appropriate, remove contaminated soil. Follow prescribed procedures for reporting and responding to larger releases.		
SECTION VII HANDLING AND STORAGE		
Do not weld, heat or drill container. Replace cap or bung. Emptied container still contains hazardous material which may ignite with explosive violence if heated sufficiently. Minimum feasible handling temperature should be maintained. Periods of exposure to high temperatures should be minimized. Water contamination should be avoided. CAUTION: Do not use pressure to empty drum or drum may rupture with explosive force.		
SECTION VIII EXPOSURE CONTROLS/PERSONAL PROTECTION		
Eye Protection:	Chemical type goggles or face shield optional.	
Skin Protection:	Avoid prolonged or frequently repeated skin contact by wearing impervious protective clothing including gloves.	
Respiratory Protection:	Wear a breathing mask.	
Ventilation:	No special ventilation is usually necessary. However, if operating conditions create high air borne concentrations of this material, special ventilation may be needed.	
Other clothing and equipment:	No special clothing or equipment is usually necessary.	
Work practices, hygienic practices:	No information is available.	
Other handling and storage requirements:	No information is available.	
Protective measures during maintenance of contaminated equipment:	No data available.	
SECTION IX PHYSICAL AND CHEMICAL PROPERTIES		
Odor		Slight odor
Appearance		Light brown liquid
Boiling point	°C	No Data Available
Solubility		Insoluble in water
Density	@15°C, g/cm <sup>3</sup>	0.885
Pour point	°C	-42.5
DMSO Extract (Base oil)	Mass % (IP 346)	< 3

<b>SECTION X STABILITY AND REACTIVITY</b>	
Stability:	Stable
Condition to Avoid:	See the Handling and Storage section for further details.
Incompatibility (materials to avoid):	Acids. Oxidizing agents. Halogens and halogenated compounds.
Hazardous Polymerization:	Will not occur.
Thermal decomposition:	Smoke, carbon monoxide, aldehydes and other products of incomplete combustion. Hydrogen sulfide and alkyl mercaptans and sulfides may also be released. Under combustion conditions, oxides of the following elements will be formed: Calcium, Sulfur, Zinc.
<b>SECTION XI TOXICOLOGICAL INFORMATION</b>	
Acute Oral:	No Data Available Believed to be greater than 5 g/kg (rat) Practically non-toxic
Dermal:	No Data Available Believed to be greater than 3 g/kg (rabbit) Practically non-toxic
Carcinogen:	OSHA This material is listed as Group 3 by IARC
(Base oil) EU	The classification as a carcinogen need not apply.
<b>SECTION XII ECOLOGICAL INFORMATION</b>	
Biodegradation:	No Data Available
Environmental fate:	This material is not expected to present any environmental problems other than those associated with oil spills.
<b>SECTION XIII DISPOSAL CONSIDERATIONS</b>	
Waste Disposal Method:	
Place contaminated materials in disposable containers and dispose of in a manner consistent with applicable regulations. Contact local environmental or health authorities for approved disposal of this material.	
<b>SECTION XIV TRANSPORT INFORMATION</b>	
The description shown may not apply to all shipping situations.	
DOT Proper Shipping Name:	Not applicable
IMDG Proper Shipping Name:	Not applicable
ICAO Proper Shipping Name:	Not applicable
TDG Proper Shipping Name:	Not applicable
NFPA Proper name:	Class 1.
UN Number:	Not applicable

SECTION XV REGULATION INFORMATION	
The U.S. TSCA inventory:	All components of this material are on the US TSCA inventory.
The EC EINECS inventory:	All components of this material are on the EC EINECS inventory.
The CANADA DSL inventory:	May require notification before sale in CANADA.
The AUSTRALIA AICS inventory:	May require notification before sale in AUSTRALIA.
The KOREA TCCL inventory:	May require notification before sale in KOREA.
The PHILIPPINE PICCS inventory:	No Data Available.
SECTION XVI OTHER INFORMATION	
None	
References:	
1. Handbook of Toxic and Hazardous Chemicals and Carcinogens (2 <sup>nd</sup> . ed.)	
2. Registry of Toxic Effects of Chemical Substances (HIOSH, 1983)	
Material safety data sheets are provided as reference information on the safe handling of hazardous or harmful materials to companies using such materials. When referring to this data sheet, companies should remember that they must take responsibility for implementing the proper measures for their own particular situations. This data sheet is not a guarantee of safety.	

**8.2 NER Model Gear Box Oil Material Safety Data Sheet (MSDS)**

<b>SECTION I</b>		
MANUFACTURER'S NAME Nippon Oil Co., Ltd.	EMERGENCY TELEPHONE NUMBER 03-3502-9161	TELEPHONE NUMBER FOR INFORMATION 03-3502-1111
ADDRESS 3-12, Nishi Shimbashi 1-chome, Nimato-ku, Tokyo, 105 Japan		
DATE PREPARED Oct. 14, 1992	SIGNATURE OF PREPARER Signature on file at Harrington Hoists, Inc.	
TRADE NAME AND SYNONYMS BONNOC M 260	CHEMICAL NAME AND SYNONYMS Industrial gear oil	
WARNING STATEMENT CAUTION: Prolonged or repeated inhalation of fumes or contact with skin can be harmful.		
<b>SECTION II TYPICAL COMPOSITION</b>		
Base oil: (highly refined mineral oil)		>94%
Additives: (Oxidation inhibitor, Rust inhibitor, Emulsion breaker, Antiwear Agent, Antifoamer, Friction modifier)		<6%
Notes: These materials are listed in TSCA chemical substance inventory. The carcinogens that are listed in federal OSHA, IARC, NTP are not used in this product.		
<b>SECTION III EXPOSURE STANDARD</b>		
No OSHA exposure or Threshold Limit Value (TLV) has been established for this material. The suggested TLV is 5 mg/m <sup>3</sup> for a daily 8-hour exposure. This is the OSHA exposure standard and the TLV (1990-1991) for mineral oil mists.		
<b>SECTION IV OCCUPATIONAL CONTROL PROCEDURES</b>		
Eye protection:	Chemical type goggles or face shield optional.	
Skin protection:	Avoid prolonged or frequently repeated skin contact with wearing impervious protective clothing including gloves.	
Respiratory protection:	No special respiratory protection is normally required.	
Ventilation:	No special ventilation is usually necessary. However, if operating condition create high airborne concentrations of this material, special ventilation may be needed.	
Other clothing and equipment:	No special clothing and equipment is usually necessary.	
Work practices, hygienic practices:	No information is available.	
Other handling and storage requirements:	No information is available.	
Protective measures during maintenance contaminated equipment:	No information is available.	

SECTION V	HEALTH HAZARD INFORMATION
<p>SYMPTOMS OF OVEREXPOSURE FOR EACH POTENTIAL ROUTE OF EXPOSURE</p> <p>Inhalation: Not expected to be acutely toxic by inhalation.</p> <p>Skin: Expected to cause no more than minor skin irritation, but prolonged or frequently repeated skin contact may be harmful.</p> <p>Eyes: Expected to cause no more than minor irritation.</p> <p>Absorption through skin: No information is available.</p> <p>Ingestion: Not expected to be acutely toxic by ingestion.</p> <p>HEALTH EFFECTS OR RISK FROM EXPOSURE</p> <p>Acute: No information is available.</p> <p>Chronic: No information is available.</p> <p>MEDICAL CONDITIONS AGGRAVATED BY EXPOSURE</p> <p>No information is available.</p>	
SECTION VI	EMERGENCY AND FIRST AID PROCEDURES
<p>Eyes: Wash eyes with fresh water for at least 15 minutes. If irritation continues, see a doctor.</p> <p>Skin: Wash skin thoroughly with soap and water. Launder contaminated clothing.</p> <p>Inhalation: None considered necessary.</p> <p>Ingestion: If swallowed, give a large amount of water to drink, make person vomit and call a doctor.</p> <p>Sensitization property: Unknown</p>	
SECTION VII	MEDIAN LETHAL DOSE (LD <sub>50</sub> )
<p>Oral: N.D. ; Believed to be greater than 5g/kg (rat) ; Practically non-toxic</p> <p>Dermal: N.D. ; Believed to be greater than 3g/kg (rabbit) ; Practically non-toxic</p>	
SECTION VIII	FIRE PROTECTION INFORMATION
<p>Flash Point °C 240</p> <p>Autoignition Temp. °C N. D.</p> <p>Flammability Limits N. D.</p> <p>Extinguishing Media: Carbon Dioxide (CO<sub>2</sub>), Dry chemical foam, Water fog, or spray.</p>	
SECTION IX	REACTIVITY DATA
<p>Stability: <u> X </u> Stable <u> </u> Unstable</p> <p>Conditions to avoid: Do not store at high temperature.</p> <p>Incompatibility (materials to avoid): May react with strong oxidizing materials.</p> <p>Hazardous polymerization: <u> </u> May occur <u> X </u> Will not occur</p>	

SECTION X      REQUIREMENTS FOR TRANSPORTATION, HANDLING, AND STORAGE		
Minimum feasible handling temperatures should be maintained. Periods of exposure to high temperatures should be minimized. Water contamination should be avoided.		
SECTION XI      SPILL, LEAK, AND DISPOSAL PROCEDURES		
PROCEDURES IN CASE OF BREAKAGE OR LEAKAGE Wipe up or absorb on suitable material and shovel up. <u>WASTE DISPOSAL METHOD</u> Place contaminated materials in disposable containers and bury in an approved dumping area.		
SECTION XII      CHEMICAL AND PHYSICAL PROPERTIES		
Density	15°C g/cm <sup>3</sup>	0.900
Viscosity	C5t @40°C	260
Solubility		Insoluble in water
Boiling point		N. D.
Evaporation rate		N. D.
Vapor pressure	mmHg	N. D.
Vapor Density		N. D.
PH of undiluted product		N. D.
Percent Volatile by volume		N. D.
Appearance		Green colored liquid
Odor		Little odor
		N. D. – not determined

### 8.3 (N)ER Model Load Chain Grease Material Safety Data Sheet (MSDS)

Effective date: November 9, 1999		MSDS No. 601008	
SECTION 1. CHEMICAL PRODUCT AND COMPANY IDENTIFICATION			
COMPANY IDENTIFICATION	NIPPON MITSUBISHI OIL CORPORATION 3-12, Nishi Shimbashi 1-chome, Minato-ku, Tokyo, 105-8412, Japan		
EMERGENCY TELEPHONE NUMBER:	+81-3-3502-9168		
TELEPHONE NUMBER FOR INFORMATION:	+81-3-3502-1111		
FAX NUMBER FOR INFORMATION:	+81-3-3502-9365		
PRODUCT NAME:	EPNOC GREASE AP O		
PRODUCT USE:	Lubricating grease		
SECTION 2. COMPOSITION/INFORMATION ON INGREDIENTS			
COMPOSITION			
<u>Components</u>	<u>Amount (%)</u>	<u>Limit</u>	
Highly refined petroleum oil	>89	5mg/m <sup>3</sup> TWA-OSHA (Mineral Oil Mist #1) 5 mg/m <sup>3</sup> TWA-ACGIH (Mineral Oil Mist #1)	
Thickener (Lithium Soap)	< 4		
Additives	< 7		
Friction Modifiers			
Oxidation Inhibitors			
Rust Inhibitors			
<u>Hazardous Information</u>			
#1 Highly refined petroleum oil, by definition, is considered hazardous according OSHA. Because it carries the Threshold Limit Value (TLV) for mineral oil mist.			

<b>SECTION 3. HAZARDS IDENTIFICATION</b>	
<b>EMERGENCY OVERVIEW</b>	
Warning statement: Caution! Prolonged or repeated contact with skin may cause irritation in some cases.	
Precautionary Measures: Avoid breathing vapor and mist. Keep container closed. Avoid contact with eyes, skin, and clothing. Wash thoroughly after handling. Keep away from heat.	
Potential health effect: Eyes: May cause minor irritation. Skin: May cause minimal skin irritation. Inhalation: Vapor or mist, in excess of permissible concentrations, or in unusually high concentrations generated from spraying, heating the material, or as from exposure in poorly ventilated areas or confined spaces, may cause irritation of the nose and throat, headache, nausea and drowsiness. Ingestion: May cause abdominal discomfort, nausea or diarrhea.	
Sensitization properties: Unknown	
Chronic Properties: If prolonged exposure occurs, nausea, headache, diarrhea, and physical discomfort.	
Other remarks: None	
<b>SECTION 4. FIRST AID MEASURES</b>	
Eyes: Flush immediately with water for at least 15 minutes. Get immediate medical attention. Skin: Wash with soap and water. Get medical attention if irritation develops. Launder contaminated clothing before reuse. Inhalation: Remove exposed person to fresh air if adverse effects are observed. Ingestion: Do not make person vomit unless directed to do so by medical personnel. Note to physician: Treat symptomatically.	
<b>SECTION 5. FIRE FIGHTING MEASURES</b>	
Flash point (Typical), °C: Not Determined Autoignition tempt., °C: Not Determined Flammability limits: Not Determined Extinguishing media: Carbon Dioxide (CO <sub>2</sub> ), dry chemical, or foam. Special fire fighting procedures: Recommend wearing self-contained breathing apparatus. Water may cause splattering. Material will float on water. Unusual fire & explosion hazards: Toxic fumes, gases or vapors may evolve on burning. Explosion date: Material does not have explosive properties.	

SECTION 6. ACCIDENTAL RELEASE MEASURES		
Procedures in Case of Accidental Release, Breakage, or Leakage: Stop the source of the leak or release. Clean up releases as soon as possible. Contain liquid to prevent further contamination of soil, surface water or groundwater. Clean up small spills using appropriate techniques such as absorbent materials or pumping. Where feasible and appropriate, remove contaminated soil. Follow prescribed procedures for reporting and responding to larger releases.		
SECTION 7. HANDLING AND STORAGE		
Do not weld, heat or drill container. Replace cap or bung. Emptied container still contains hazardous material which may ignite with explosive violence if heated sufficiently. Minimum feasible handling temperature should be maintained. Periods of exposure to high temperatures should be minimized. Water contamination should be avoided. CAUTION: Do not use pressure to empty drum or drum may rupture with explosive force.		
SECTION 8. EXPOSURE CONTROLS/PERSONAL PROTECTION		
Eye Protection:	Chemical type goggles or face shield optional.	
Skin Protection:	Avoid prolonged or frequently repeated skin contact by wearing impervious protective clothing including gloves.	
Respiratory Protection:	Wear a breathing mask.	
Ventilation:	No special ventilation is usually necessary. However, if operating conditions create high air borne concentrations of this material, special ventilation may be needed.	
Other clothing and equipment:	No special clothing or equipment is usually necessary.	
Work practices, hygienic practices:	No information is available.	
Other handling and storage requirements:	No information is available.	
Protective measures during maintenance of contaminated equipment:	No data available.	
SECTION 9. PHYSICAL AND CHEMICAL PROPERTIES		
Odor		Slight odor
Appearance		Light brown buttery
Boiling point	°C	No Data Available
Solubility		Insoluble in water
Density	@15°C, g/cm <sup>3</sup>	No data available
Dropping point	°C	186
Penetration worked	@25°C, 60W	359
DMSO Extract (Base oil)	Mass % (IP 346)	< 3

<b>SECTION 10. STABILITY AND REACTIVITY</b>	
Stability:	Stable
Condition to Avoid:	See the Handling and Storage section for further details.
Incompatibility (materials to avoid):	Acids. Oxidizing agents. Halogens and halogenated compounds.
Hazardous Polymerization:	Will not occur.
Thermal decomposition:	Smoke, carbon monoxide, aldehydes and other products of incomplete combustion. Hydrogen sulfide and alkyl mercaptans and sulfides may also be released. Under combustion conditions, oxides of the following elements will be formed: Calcium, Sulfur, Zinc.
<b>SECTION 11. TOXICOLOGICAL INFORMATION</b>	
Acute Oral:	No Data Available Believed to be greater than 5/kg (rat) Practically non-toxic
Dermal:	No Data Available Believed to be greater than 3 g/kg (rabbit) Practically non-toxic
Carcinogen:	OSHA This material is listed as Group 3 by IARC
(Base oil) EU	The classification as a carcinogen need not apply.
<b>SECTION 12. ECOLOGICAL INFORMATION</b>	
Biodegradation:	No Data Available
Environmental fate:	This material is not expected to present any environmental problems other than those associated with oil spills.
<b>SECTION 13. DISPOSAL CONSIDERATIONS</b>	
Waste Disposal Method: Place contaminated materials in disposable containers and dispose of in a manner consistent with applicable regulations. Contact local environmental or health authorities for approved disposal of this material.	
<b>SECTION 14. TRANSPORT INFORMATION</b>	
The description shown may not apply to all shipping situations.	
DOT Proper Shipping Name:	Not applicable
IMDG Proper Shipping Name:	Not applicable
ICAO Proper Shipping Name:	Not applicable
TDG Proper Shipping Name:	Not applicable
NFPA Proper name:	Class 1.
UN Number:	Not applicable

SECTION 15. REGULATION INFORMATION	
The U.S. TSCA inventory:	All components of this material are on the US TSCA inventory. May require notification before sale in US. No data available.
The EC EINECS inventory:	All components of this material are on the EC EINECS inventory. May require notification before sale in EC. No data available. Some components of this material is on the EC ELINCS inventory. The other components are on the EC EINECS inventory.
The CANADA DSL inventory:	All components of this material are on the DSL inventory. May require notification before sale in CANADA. No data available.
The AUSTRALIA AICS inventory:	All components of this material are on the AICS inventory. May require notification before sale in AUSTRALIA. No data available.
The KOREA TCCL inventory:	All components of this material are on the TCCL inventory. May require notification before sale in KOREA. No data available.
The PHILIPPINE PICCS inventory:	All components of this material are on the PICCS inventory. May require notification before sale in PHILIPPINE. No Data Available.
SECTION 16 OTHER INFORMATION	
None	
References:	
3. Handbook of Toxic and Hazardous Chemicals and Carcinogens (2 <sup>nd</sup> . ed.)	
4. Registry of Toxic Effects of Chemical Substances (HIOSH, 1983)	
Material safety data sheets are provided as reference information on the safe handling of hazardous or harmful materials to companies using such materials. When referring to this data sheet, companies should remember that they must take responsibility for implementing the proper measures for their own particular situations. This data sheet is not a guarantee of safety.	

## **9.0 Warranty**

All products sold by Harrington Hoists, Inc. are warranted to be free from defects in material and workmanship from date of shipment by Harrington for the following periods:

**Manual Hoists & Trolleys - 2 years**

**Air and Electric Powered Hoists, Trolleys, and Crane Components - 1 year**

**Spare / Replacement Parts - 1 year**

The product must be used in accordance with manufacturer's recommendations and must not have been subject to abuse, lack of maintenance, misuse, negligence, or unauthorized repairs or alterations.

Should any defect in material or workmanship occur during the above time period in any product, as determined by Harrington Hoist's inspection of the product, Harrington Hoists, Inc. agrees, at its discretion, either to replace (not including installation) or repair the part or product free of charge and deliver said item F.O.B. Harrington Hoists, Inc. place of business to customer.

Customer must obtain a Return Goods Authorization as directed by Harrington or Harrington's published repair center prior to shipping product for warranty evaluation. An explanation of the complaint must accompany the product. Product must be returned freight prepaid. Upon repair, the product will be covered for the remainder of the original warranty period. If it is determined there is no defect, or that the defect resulted from causes not within the scope of Harrington's warranty, the customer will be responsible for the costs of returning the product.

Harrington Hoists, Inc. disclaims any and all other warranties of any kind expressed or implied as to the product's merchantability or fitness for a particular application. Harrington will not be liable for death, injuries to persons or property or for incidental, contingent, special or consequential damages, loss or expense arising in connection with the use or inability whatever, regardless of whether damage, loss or expense results from any act or failure to act by Harrington, whether negligent or willful, or from any other reason.

**This Page Intentionally Left Blank**