OWNER'S MANUAL

MOTORIZED TROLLEY MR2 SERIES

1 Ton through 20 Ton Capacity

Code, Lot and Serial Number

▲WARNING

This equipment should not be installed, operated or maintained by any person who has not read and understood all the contents of this manual. Failure to read and comply with the contents of this manual can result in serious bodily injury or death, and/or property damage.

HARRINGTON
A KITO GROUP COMPANY

Table of Contents

Section	Page Number
1.0 Important Information and Warnings.....	4
1.1 Terms and Summary	
1.2 Warning Tag and Labels	
2.0 Technical Information	8
2.1 Specifications	
2.2 Dimensions	
3.0 Pre-operational Procedures.....	11
3.1 Assembly and Adjustment	
3.2 Mounting Location	
3.3 Installation of Trolley onto Beam	
3.4 Electrical Connections	
3.5 VFD Setup (Dual Speed Only)	
3.6 Pre-operational Checks and Trial Operation	
4.0 Operation.....	34
4.1 Introduction	
4.2 Shall's and Shall Not's for Operation	
4.3 Trolley and Hoist Controls	
5.0 Inspection.....	38
5.1 General	
5.2 Inspection Classification	
5.3 Frequent Inspection	
5.4 Periodic Inspection	
5.5 Occasionally Used Trolleys	
5.6 Inspection Records	
5.7 Inspection Methods and Criteria	

Section	Page Number
6.0 Maintenance & Handling.....	44
6.1 Count/Hour Meter (Dual Speed Only)	
6.2 Lubrication	
6.3 Brake	
6.4 Storage	
6.5 Outdoor Installation	
6.6 Operational Environment	
7.0 Troubleshooting.....	47
8.0 Warranty.....	49
9.0 Parts List.....	51

1.0 Important Information and Warnings

1.1 Terms and Summary

This manual provides important information for personnel involved with the installation, operation and maintenance of this product. Although you may be familiar with this or similar equipment, it is strongly recommended that you read this manual before installing, operating or maintaining the product.

Danger, Warning, Caution and Notice - Throughout this manual there are steps and procedures that can present hazardous situations. The following signal words are used to identify the degree or level of hazard seriousness.

▲▲ DANGER Danger indicates an imminently hazardous situation which, if not avoided, **will** result in **death or serious injury**, and property damage.

▲▲ WARNING Warning indicates an imminently hazardous situation which, if not avoided, **could** result in **death or serious injury**, and property damage.

▲▲ CAUTION Caution indicates a potentially hazardous situation which, if not avoided, **may** result **minor or moderate injury** or property damage.

NOTICE Notice is used to notify people of installation, operation, or maintenance information which is important but not directly hazard-related.

▲▲ CAUTION

These general instructions deal with the normal installation, operation, and maintenance situations encountered with the equipment described herein. The instructions should not be interpreted to anticipate every possible contingency or to anticipate the final system, crane, or configuration that uses this equipment. For systems using the equipment covered by this manual, the supplier and owner of the system are responsible for the system's compliance with all applicable industry standards, and with all applicable federal, state and local regulations/codes.

This manual includes instructions and parts information for a variety of trolley and hoist types. Therefore, all instructions and parts information may not apply to any one type or size of specific trolley or hoist. Disregard those portions of the instructions that do not apply.

Record your trolley's Code, Lot and Serial Number on the front cover of this manual for identification and future reference to avoid referring to the wrong manual for information or instructions on installation, operation, inspection, maintenance, or parts.

Use only Harrington authorized replacement parts in the service and maintenance of this trolley.

WARNING

Equipment described herein is not designed for and **MUST NOT** be used for lifting, supporting, or transporting people, or for lifting or supporting loads over people.

Equipment described herein should not be used in conjunction with other equipment unless necessary and/or required safety devices applicable to the system, crane, or application are installed by the system designer, system manufacturer, crane manufacturer, installer, or user.

Modifications to upgrade, rerate, or otherwise alter this equipment shall be authorized only by the original equipment manufacturer.

Equipment described herein may be used in the design and manufacture of cranes or monorails. Additional equipment or devices may be required for the crane and monorail to comply with applicable crane design and safety standards. The crane designer, crane manufacturer, or user is responsible to furnish these additional items for compliance. Refer to ANSI/ASME B30.17, "Safety Standard for Top-Running Single Girder Cranes"; ANSI/ASME B30.2 "Safety Standard for Top-Running Double-Girder Cranes"; and ANSI/ASME B30.11 "Safety Standard for Underhung Cranes and Monorails".

If a below-the-hook lifting device or sling is used with a hoist, refer to ANSI/ASME B30.9, "Safety Standard for Slings" or ANSI/ASME B30.20, "Safety Standard for Below-the-Hook Lifting Devices".

Hoists, trolleys and cranes, used to handle hot molten material may require additional equipment or devices. Refer to ANSI Z241.2, "Safety Requirements for Melting and Pouring of Metals in the Metal Casting Industry".

Electrical equipment described herein is designed and built in compliance with Harrington's interpretation of ANSI/NFPA 70, "National Electrical Code". The system designer, system manufacturer, crane designer, crane manufacturer, installer, or user is responsible to assure that the installation and associated wiring of these electrical components is in compliance with ANSI/NFPA 70, and all applicable Federal, State and Local Codes.

Failure to read and comply with any one of the limitations noted herein can result in serious bodily injury or death, and/or property damage.

DANGER

HAZARDOUS VOLTAGES ARE PRESENT IN THE CONTROL BOX, OTHER ELECTRICAL COMPONENTS, AND CONNECTIONS BETWEEN THESE COMPONENTS.

Before performing ANY mechanical or electrical maintenance on the equipment, de-energize (disconnect) the main switch supplying power to the equipment; and lock and tag the main switch in the de-energized position. Refer to ANSI Z244.1, "Personnel Protection – Lockout/Tagout of Energy Sources".

Only trained and competent personnel should inspect and repair this equipment.

NOTICE

It is the responsibility of the owner/user to install, inspect, test, maintain, and operate a trolley or hoist in accordance with ANSI/ASME B30.16, "Safety Standard for Overhead Hoists", OSHA Regulations and ANSI/NFPA 70, "National Electric Code". If the trolley is installed as part of a total lifting system, such as an overhead crane or monorail, it is also the responsibility of the owner/user to comply with the applicable ANSI/ASME B30 volume that addresses that type of equipment.

It is the responsibility of the owner/user to have all personnel that will install, inspect, test, maintain, and operate a hoist read the contents of this manual and applicable portions of ANSI/ASME B30.16, "Safety Standard for Overhead Hoists", OSHA Regulations and ANSI/NFPA 70, "National Electric Code". If the trolley is installed as part of a total lifting system, such as an overhead crane, the applicable ANSI/ASME B30 volume that addresses that type of equipment must also be read by all personnel.

If the trolley owner/user requires additional information, or if any information in the manual is not clear, contact Harrington or the distributor of the trolley. Do not install, inspect, test, maintain, or operate this trolley unless this information is fully understood.

A regular schedule of inspection of the trolley in accordance with the requirements of ANSI/ASME B30.16 should be established and records maintained.

1.2 Warning Tag and Labels

The warning tag illustrated below in Figure 1-1 is supplied with each trolley shipped from the factory. If the tag is not attached to the pendant cord for your hoist/trolley, order a tag from your dealer and install it. Read and obey all warnings attached to this trolley. Tag is not shown actual size.

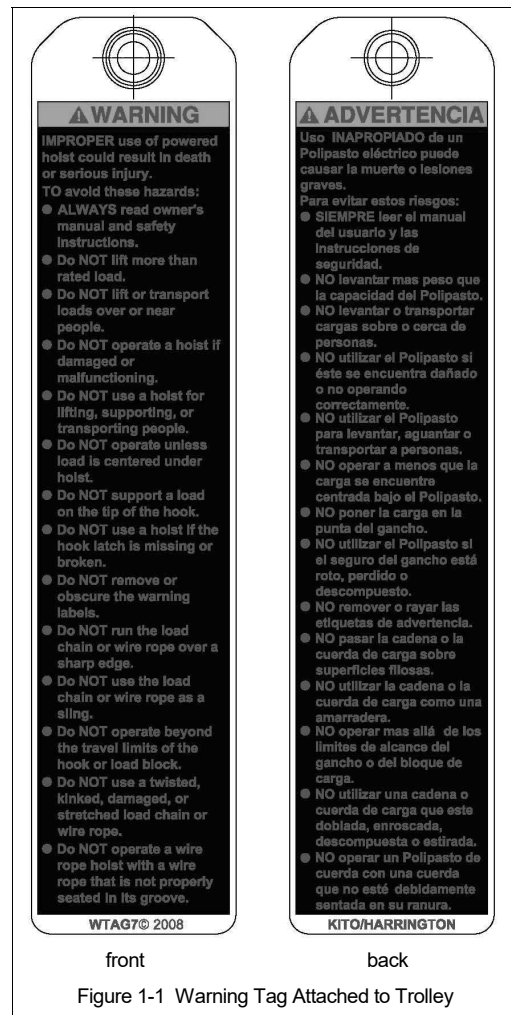

2.0 Technical Information

2.1 Specifications

Note: This Owner's Manual is to be used with the *Enhanced Features Model ER and NER*. The *Enhanced Features Model* is referred to as the ER2 and NER2 in this Owner's Manual.

Pendants are shown with optional *Emergency Stop* button.

2.1.1 Product Code for MR Trolley Alone:

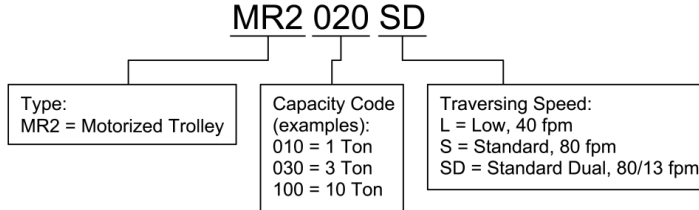

2.1.2 Product Code for MR2 Trolley with ER2 Series Electric Hoist:

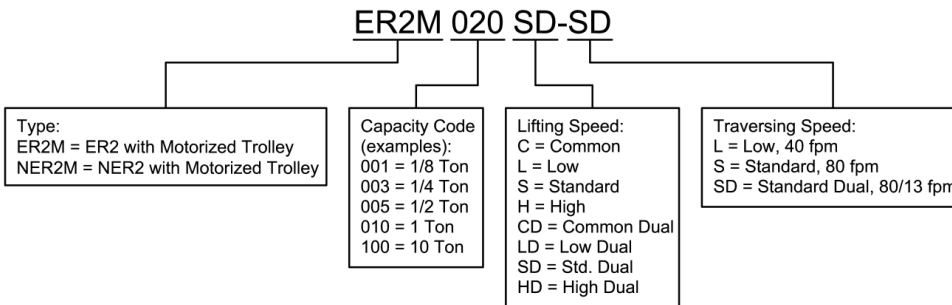

Table 2-1 Trolley Specifications									
Capacity (Ton)	Product Code	Standard Beam Flange Range (in)	Optional Beam Flange Range (in)	Min. Allowable Radius for Curve (in)	Motor***			Approx. Net Weight (lbs)	
					Output (Hp)	Current Draw (amps)			
						208V or 230V	460V		
SINGLE SPEED	1	MR2010L/S	2.28 to 5.00	5.01 to 6.02 <u>OR</u> 6.03 to 12.00	31.5*	0.54	3.2	1.6	68
	2	MR2020L/S	3.23 to 6.02	6.03 to 7.02 <u>OR</u> 7.03 to 12.00	31.5**	0.54	3.2	1.6	84
	3	MR2030L/S	3.23 to 6.02	6.03 to 7.02 <u>OR</u> 7.03 to 12.00	39.4	0.54	3.2	1.6	106
	5	MR2050L/S	3.94 to 7.01	7.02 to 7.60 <u>OR</u> 7.61 to 12.00	70.9	1.0	5.1	2.5	154
	8	MR2080L	5.50 to 8.66	8.67 to 12.00	98.4	1.0	5.1	2.5	289
	10	MR2100L	5.50 to 8.66	8.67 to 12.00	98.4	1.0	5.1	2.5	289
	15	MR2150L	5.50 to 8.66	8.67 to 12.00	∞	1.0 x 2	5.1 x 2	2.5 x 2	368
20	MR2200L	5.50 to 8.66	8.67 to 12.00	∞	1.0 x 2	5.1 x 2	2.5 x 2	335	
DUAL SPEED	1	MR2010SD	2.28 to 5.00	5.01 to 6.02 <u>OR</u> 6.03 to 12.00	31.5	0.54	3.4	1.7	75
	2	MR2020SD	3.23 to 6.02	6.03 to 7.02 <u>OR</u> 7.03 to 12.00	31.5	0.54	3.4	1.7	93
	3	MR2030SD	3.23 to 6.02	6.03 to 7.02 <u>OR</u> 7.03 to 12.00	39.4	0.54	3.4	1.7	110
	5	MR2050SD	3.94 to 7.01	7.02 to 7.60 <u>OR</u> 7.61 to 12.00	70.9	1.0	5.4	2.7	165

*Flange widths smaller than 4 inches will have a minimum radius of 137.8 inches.

**Flange widths smaller than 5 inches will have a minimum radius of 39.4 inches.

*** Although both 208/230 & 460 Volts are shown together, the dual speed motors are **NOT** reconnectable.

2.1.3 Operating Conditions and Environment

Temperature Range: -4° to +104°F (-20° to +40°C)

Humidity: 85% or less (no condensation)

Noise Level: 85 dB or less (A scale: measured 1 meter away from the electric chain hoist)

Enclosure Rating: Trolley Meets IP55, Pendant Meets IP 65

Supply Voltage: Standard 208-230/460V-3-60, Optional 575V-3-60, Special Voltages Available

Intermittent Duty Rating: Single Speed – 40% ED 240 starts per hour
Dual Speed – 27/13% ED with 78/162 starts per hour

Trolley Duty Rating: ISO M4/5; ASME H4

2.2 Dimensions

Table 2-2 Trolley Dimensions

Product Code		b	b'	d	e	e'	i	j	k	m	n	r	t
Single Speed	MR2010L/S	12.4	15.6	8.7	20.3	7.1	3.74	0.9	5.1	8.1	4.3	2.0	1.22
	MR2020L/S	12.8	16.4	8.9	20.5	7.2	4.33	1.1	4.9	8.4	4.7	2.4	1.42
	MR2030L/S	13.4	17.4	8.9	20.5	7.3	4.92	1.1	5.2	8.5	5.2	2.7	1.69
	MR2050L/S	15.8	19.8	11.1	20.8	7.6	5.51	1.7	5.7	9.2	5.9	3.4	2.13
	MR2080L	19.7	22.9	11.2	20.9	8.8	6.89	3.4	6.9	10.6	7.5	6.0	2.76
	MR2100L	19.7	22.9	11.2	20.9	8.8	6.89	3.0	6.9	10.6	7.5	6.0	2.76
	MR2150L	40.2	43.4	11.2	20.9	8.8	6.89	3.2	6.9	10.6	20.5	6.0	2.76
	MR2200L	40.2	43.4	11.2	20.9	8.8	6.89	3.0	6.9	10.6	20.5	6.0	2.76
Dual Speed	MR2010SD	12.4	15.6	8.7	20.3	7.1	3.74	0.9	5.1	8.1	4.3	2.0	1.22
	MR2020SD	12.8	16.4	8.9	20.5	7.2	4.33	1.1	4.9	8.4	4.7	2.4	1.42
	MR2030SD	13.4	17.4	8.9	20.5	7.3	4.92	1.1	5.2	8.5	5.2	2.7	1.69
	MR2050SD	15.8	19.8	11.1	20.8	7.6	5.51	1.7	5.7	9.2	5.9	3.4	2.13

3.0 Pre-operational Procedures

3.1 Assembly and Adjustment

- 3.1.1 When the MR2 trolley is combined with a hoist, follow and complete all pre-operational procedures provided with the hoist. For Harrington ER2 and NER2 model hoists, follow the pre-operational procedures in the ER2/NER2 Owner's Manual in conjunction with all information provided in this section for mounting and electrical connections.
- 3.1.2 In addition to the information and procedures provided in this section for the MR2 trolley, there are specific details for using ER2 and NER2 hoists with MR2 trolleys. Special mounting and wiring considerations must be taken if the trolley is used with a hoist other than an ER2 or NER2 model.
- 3.1.3 **⚠ WARNING** Never attempt to hook mount a hoist directly to the Suspension Shaft on trolleys up to and including 5 Ton. These trolleys are designed to be used with a suspender only and do not have the vertical clearance required for a hook to fit between the Suspension Shaft and trolley beam.
- 3.1.4 Preparing ER2 and NER2 hoists for use with MR2 trolley.
- 1/8 to 2 Ton ER2/NER2**— The standard suspension configuration uses Suspender T which orients the hoist perpendicular to the trolley beam. Optional two-piece suspension method uses a Connection Yoke and Suspender G, which orients the hoist parallel to the trolley beam. If the hoist is not equipped with Suspender T or the Connection Yoke from the factory, remove the Top Hook Assembly from the hoist and install Suspender T or the Connection Yoke as follows in step 1).
- 2 Ton (020C) and 3 Ton (030C) ER2/NER2** – The 2 Ton and 3Ton double fall ER2/NER2 hoists always use a Connection Yoke. If the hoist is not equipped with Suspender T or G from the factory, remove the Top Hook Assembly from the Connection Yoke and install the Suspender T or G as shown in Figure 3-4.
- 1) Refer to Figure 3-1.
 - 2) Remove the Shaft Retainer Clip.
 - 3) Remove the Socket Bolt and the Shaft Retainer from the other side of the Connection Shafts.
 - 4) Remove the two Connection Shafts.
 - 5) Remove the Top Hook and replace it with the Suspender T.
 - 6) Re-insert the two (2) Connection Shafts into the holes in the hoist body.
 - 7) Re-install the Shaft Retainer Clip, Shaft Retainer and the Socket Bolt on the Connection Shafts.
 - 8) If installing the Connection Yoke, place the Suspender G in the top of the Connection Yoke. Attach Suspender G to the Connection Yoke with the Yoke Bolt, Slotted Nut and Split Pin (cotter pin).
 - 9) There are two oil fill holes located in the top of the gear case on the ER2 hoist. For ER2 coupled to MR2 trolley, there are some flange widths that make it necessary to relocate the oil cap assembly to the other oil fill hole. This will prevent interference with trolley side plate. Refer to Figure 3-2.

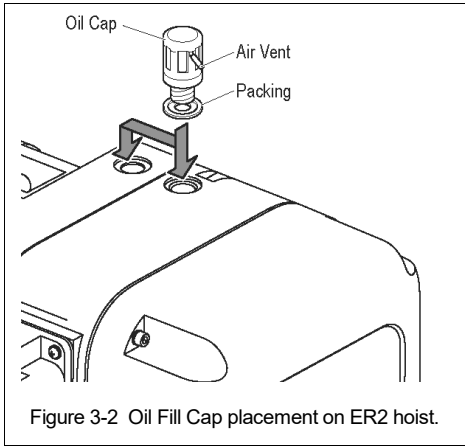
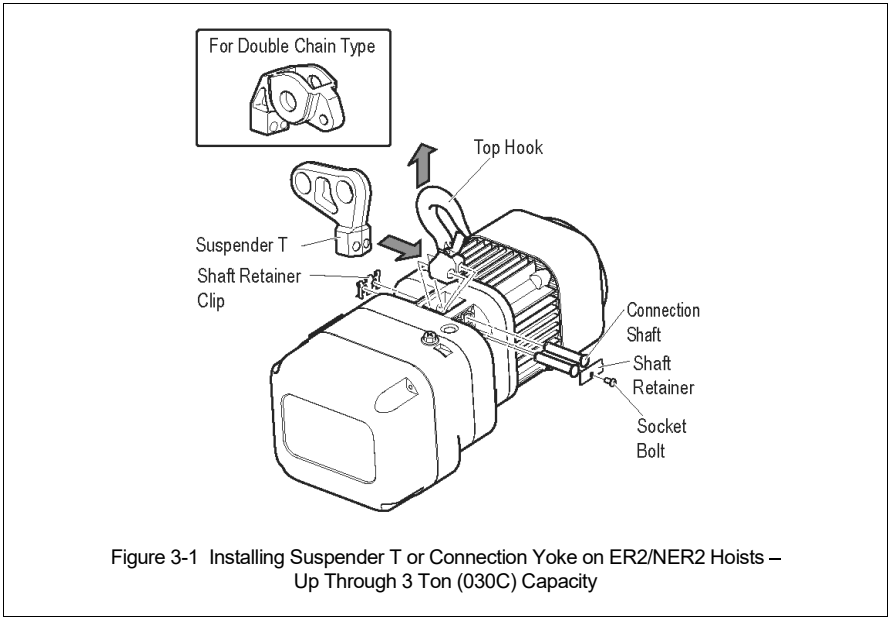

2 ½ Ton and 3 Ton (030L) ER2/NER 2– The standard suspension configuration uses Suspender T which orients the hoist perpendicular to the trolley beam. Optional two-piece suspension method uses a Connection Yoke and Suspender G, which orients the hoist parallel to the trolley beam. If the hoist is not equipped with Suspender T or the Connection Yoke from the factory, remove the Top Hook Assembly from the hoist and install Suspender T or the Connection Yoke as follows in step 1).

5 Ton ER2/NER2 – The standard suspension configuration uses Suspender T which orients the hoist perpendicular to the trolley beam. Suspender G is available as an option and orients the hoist parallel to the trolley beam. If the hoist is not equipped with Suspender T or G from the factory, remove the Top Hook Assembly from the Connection Yoke and install the Suspender T or G as shown in Figure 3-4.

- 1) Refer to Figure 3-3.
- 2) Remove the four Controller Cover socket head bolts and allow the cover to swing fully open.
- 3) Loosen the three or four captive screws holding the electrical component mounting Plate against the main body of the hoist and swing the plate out to access the required components.
- 4) Loosen one of two Machine Screws attaching Plate A and remove the second Machine Screw. Allow Plate A to rotate out from the retaining slot in the bottom side of the Connection Shaft. Pull out the Connection Shaft and remove the Top Hook Assembly.
- 5) Remove the Hoist Fixing Shaft.
- 6) Place Suspender T or the Connection Yoke on the top of the hoist. Line up the holes for the Connection Shaft and the Hoist Fixing Shaft and reinsert the shafts.
- 7) Reassemble the remaining hoist components in reverse order of disassembly.
- 8) If installing the Connection Yoke, place the Connection Yoke Rubber and Suspender G in the top of the Connection Yoke. Attach Suspender G to the Connection Yoke with the Yoke Bolt, Slotted Nut and Split Pin (cotter pin).
- 9) There are two oil fill holes located in the top of the gear case on the ER2 hoist. For ER2 coupled to MR2 trolley, there are some flange widths that make it necessary to relocate the oil cap assembly to the other oil fill hole. This will prevent interference with trolley side plate. Refer to Figure 3-2.

8 to 20 Ton ER2/NER2 – Since the trolley suspension shaft(s) passes through the hoist top plates, no additional hoist preparation is required to mount the ER2/NER2 hoist to the trolley. Hook mount ER2/NER2 hoists can not be converted to lug mount without replacing the hoist's top Suspension Plates.

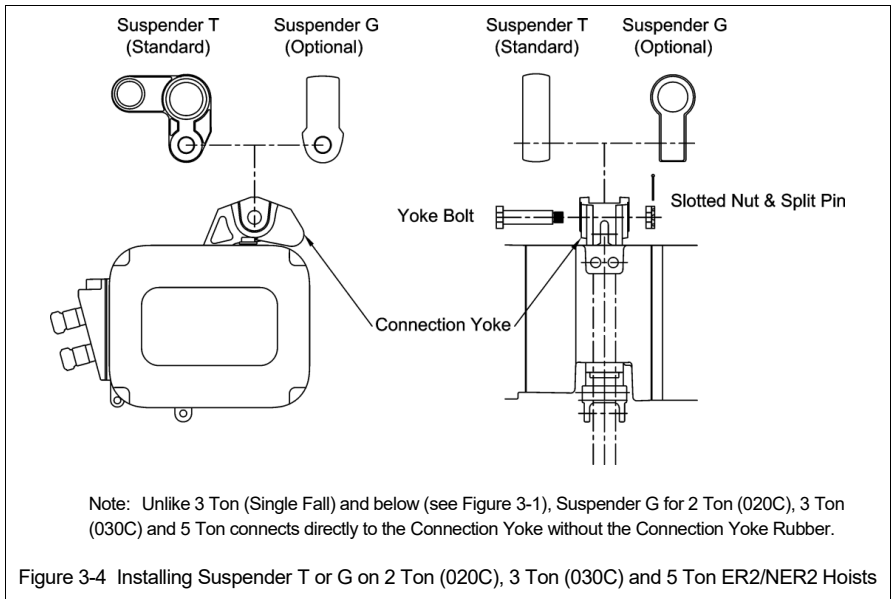
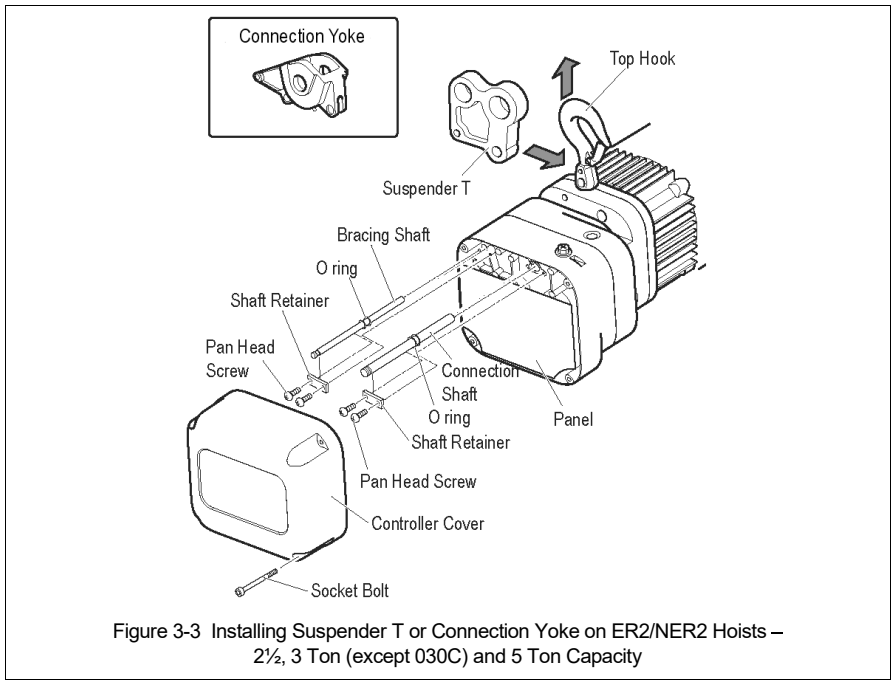

3.1.5 Trolley Assembly

- 1) Refer to Figure 3-5 or 3-6.
- 2) Remove the Shaft Stopper Pin, Side Plate S, and Spacers from the Suspension Shaft. For beam flanges that are wider than the standard range, different suspension shaft and/or spacer arrangements are provided. Refer to Table 3-1.
- 3) Insert the Suspension Shaft to Side Plate G and attach it with the Suspension Shaft Bolt, Slotted Nut and Split Pin (cotter pin). Refer to Figure 3-7 and insure that correct Suspension Shaft holes are used. Securely bend both branches of the Split Pin after insertion.
- 4) Referring to Figure 3-10, Table 3-1 and Table 3-2 install the inner adjusting Spacers and Suspender (Suspension Plates for 8 to 20 Ton) on the Suspension Shaft. Use all of the Spacers provided with the trolley. If the beam width is not listed in Table 3-2, use the next size smaller and make adjustments in accordance with Section 3.1.6.
- 5) Place Side Plate S into the Suspension Shaft.
- 6) Install the outer adjusting Spacers on the Suspension Shaft outside of Side Plate S. Insert the Shaft Stopper Pin into Hole "A" so that Split Pin is to the left when seen from the front side of trolley switch box. Temporarily install the split pin in the Shaft Stopper Pin and bend the split pin slightly to hold it in place. The split pin should be fully bent after checking and attaining the proper beam flange adjustment.
- 7) For ER2/NER2 Hoists up through 5 Ton with Suspender T - Insert the Trolley Fixing Shaft through Side Plate G, Suspender T and Side Plate S. Secure it to Side Plate G with the two split pins. Securely bend both branches of the Split Pin after insertion.
- 8) For 8 and 10 Ton ER2/NER2 Hoists - Insert the Trolley Fixing Shaft through Side Plate G, Suspension Plates and Side Plate S. Secure it to Side Plate G with two split pins. Securely bend both branches of the Split Pin after insertion.

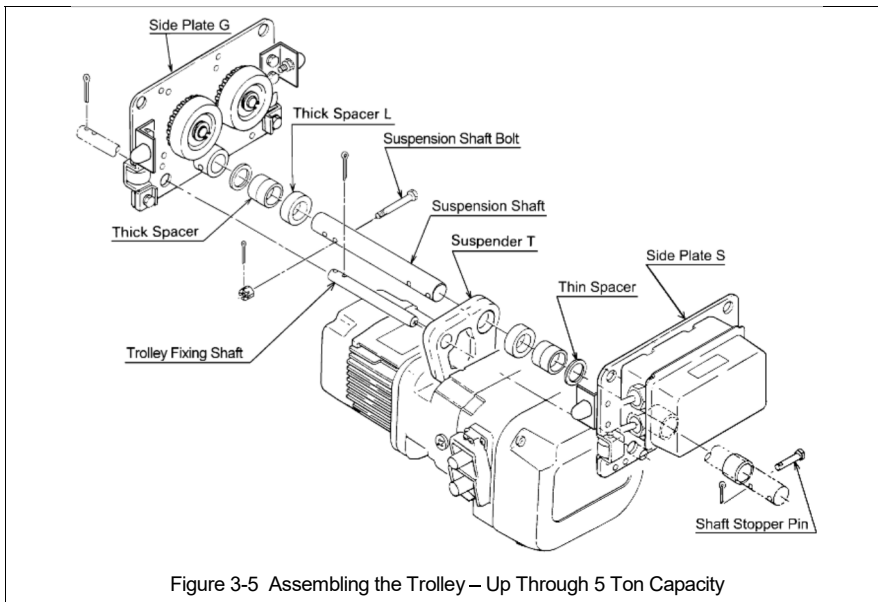
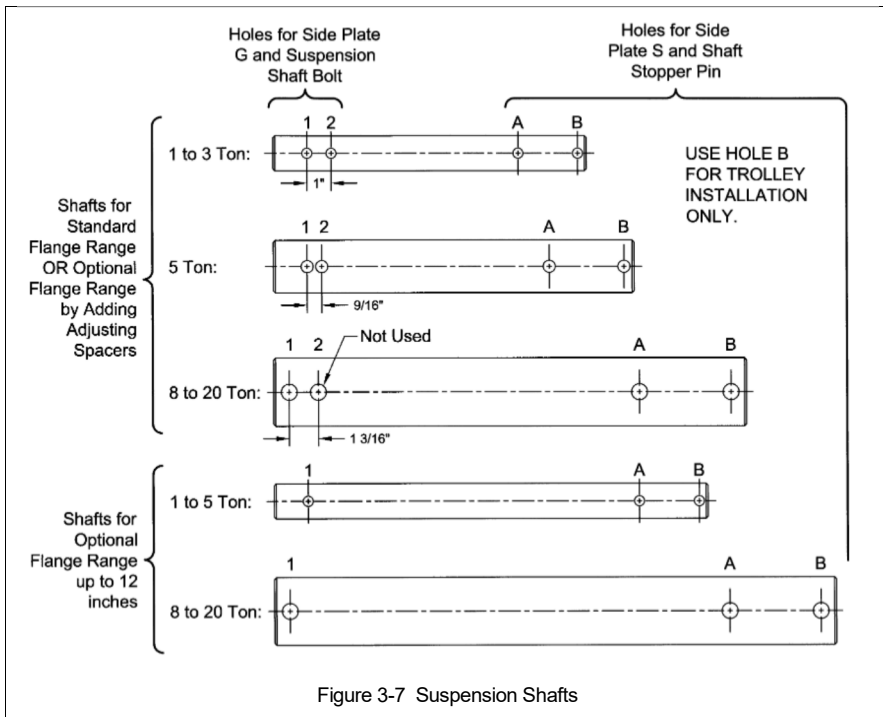
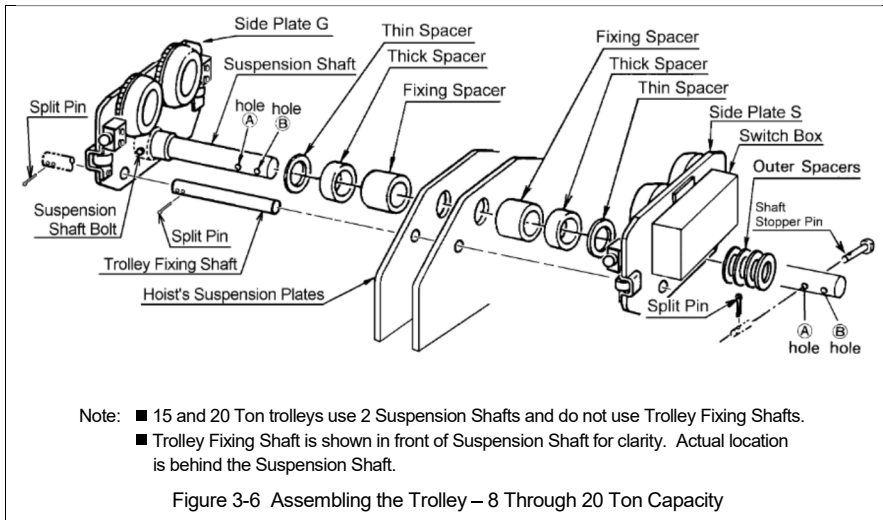
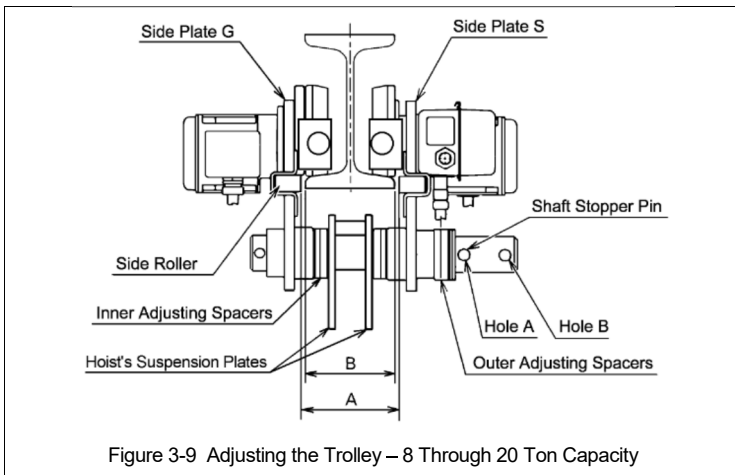
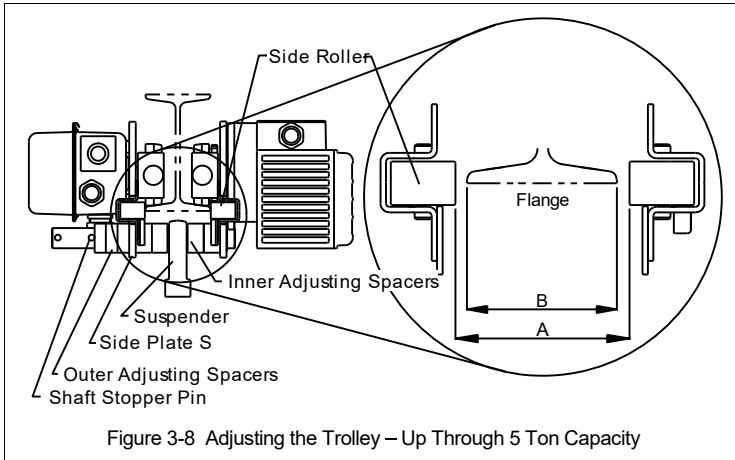

Figure 3-5 Assembling the Trolley – Up Through 5 Ton Capacity



3.1.6 Adjusting the trolley width - After assembling trolley per Section 3.1.5, check the adjustment as follows:

- 1) Refer to Figure 3-8 or 3-9.
- 2) Make sure both side plates are spread fully outward and Measure Dimension "A". Compare dimension "A" with the following values:
 - For trolleys up through 5 Ton, "A" must be 1/8 to 3/16" greater than "B".
 - For trolleys 8 Ton and larger, "A" must be 7/32 to 9/32" greater than "B".
- 3) If "A" does not fall within the specified range, move spacers from inner to outer or from outer to inner as necessary to obtain the proper "A" dimension, irrespective of the numbers in Table 3-2.
- 4) After obtaining the proper adjustment, install the Shaft Stopper Pin in Hole A, insert the Split Pin into the Shaft Stopper Pin, and securely bend both branches of the split pin.



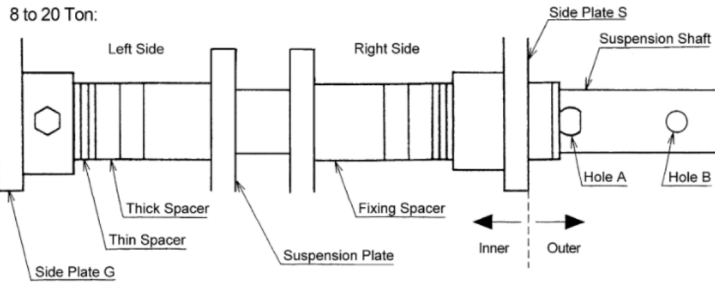
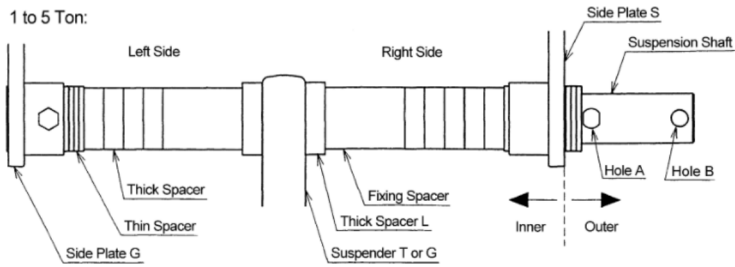

Note: Inner Spacer rows on Table 3-2 list two numbers. First number is the quantity of spacers located on the left side of the Suspender or Suspension Plates, second number is the quantity on the right side.

Example: 1 + 2 ← Adjusting Spacers on the right side (Side Plate S side)
 ↑ Adjusting Spacers on the left side (Side Plate G side)

Figure 3-10 Spacers Arrangement

Table 3-1 Suspension Shaft Adjusting Spacers, and Suspension Shaft Bolt						
Capacity (Tons)	Flange Range (in)	Total Number of Spacers Supplied				Suspension Shaft Bolt Location
		Thin	Thick	Fixing	Thick L	
1	2.28 to 5.00	8	3	—	2	Hole 2
	5.01 to 6.02	8	5	—	2	Hole 1
	6.03 to 12.00	8	9	2	2	Hole 1
2 & 3	3.23 to 6.02	8	3	—	2	Hole 2
	6.03 to 7.02	8	5	—	2	Hole 1
	7.03 to 12.00	8	9	2	2	Hole 1
5	3.94 to 7.01	8	3	—	2	Hole 2
	7.02 to 7.60	8	4	—	2	Hole 1
	7.61 to 12.00	8	13	—	2	Hole 1
8 and up	5.91 to 8.66	8	6	—	—	Hole 1
	8.67 to 12.00	8	7	2	—	Hole 1

Table 3-2 Number of Adjusting Spacers

Beam Flange Width (in)	Cap. (Ton)	Spacer Type	(mm)	2 5/16	2 1/2	2 7/8	3	3 1/4	3 9/16	3 7/8	3 15/16	4	4 3/16	4 5/16	4 7/16	4 11/16	4 15/16	5	5 3/16	5 5/16	5 3/8	5 5/8	5 7/8	5 15/16	6	6 1/8	6 5/16	6 7/16	6 11/16	6 7/8	7	
				58	64	73	75	82	90	98	100	102	106	110	113	119	125	127	131	135	137	143	149	150	153	155	160	163	170	175	178	
1	Thin	Inner	1+2	2+3	4+4	1+0	1+2	2+3	0	1+0	1+0	1+2	2+2	2+3	3+4	4+4	4+1	5+1	2+2	2+2	3+3	4+4	4+1	4+1	1+1	2+2	2+3	3+0	4+4	4+1		
		Outer	5	3	0	7	5	3	8	7	7	5	4	3	1	0	3	2	4	4	2	0	3	6	4	3	5	0	3			
	Thick	Inner	0+0	0+0	0+0	0+0	0+0	0+0	1+1	1+1	1+1	1+1	1+1	1+1	1+1	1+1	1+1	1+2	1+2	2+2	2+2	2+2	2+2	2+2	2+2	3+3	3+3	3+3	3+4	3+3	3+4	
		Outer	3	3	3	3	3	3	1	1	1	1	1	1	1	1	1	0	2	1	1	1	1	1	1	3	3	3	2	3	2	
	Fixing	Inner	—	—	—	—	—	—	—	—	—	—	—	—	—	—	—	—	—	—	—	—	—	—	—	0	0	0	0	0	0	
		Outer	—	—	—	—	—	—	—	—	—	—	—	—	—	—	—	—	—	—	—	—	—	—	—	2	2	2	2	2	2	
	Thick L	Inner	0+0	0+0	0+0	1+1	1+1	1+1	1+1	1+1	1+1	1+1	1+1	1+1	1+1	1+1	1+1	1+1	1+1	1+1	1+1	1+1	1+1	1+1	1+1	1+1	1+1	1+1	1+1	1+1	1+1	
		Outer	2	2	2	0	0	0	0	0	0	0	0	0	0	0	0	0	0	0	0	0	0	0	0	0	0	0	0	0	0	
	2 and 3	Thin	Inner					1+2	2+3	3+4	0	1+0	1+1	1+2	2+2	3+3	4+4	1+0	1+1	1+2	2+2	3+3	4+0	4+1	1+1	1+2	1+2	2+2	2+3	3+0	4+4	1+4
			Outer					5	3	1	8	7	6	5	4	2	0	7	6	5	4	2	4	3	6	5	4	2	0	3		
Thick		Inner					0+0	0+0	0+0	0+0	0+0	0+0	0+0	0+0	0+0	0+0	0+0	1+1	1+1	1+1	1+1	1+1	1+2	1+2	2+2	2+2	2+2	2+2	2+2	2+2	3+2	
		Outer					3	3	3	3	3	3	3	3	3	3	3	1	1	1	1	1	1	0	0	1	1	1	1	1	0	
Fixing		Inner					—	—	—	—	—	—	—	—	—	—	—	—	—	—	—	—	—	—	—	—	—	—	—	—	—	
		Outer					—	—	—	—	—	—	—	—	—	—	—	—	—	—	—	—	—	—	—	—	—	—	—	—	—	
Thick L		Inner					0+0	0+0	0+0	1+1	1+1	1+1	1+1	1+1	1+1	1+1	1+1	1+1	1+1	1+1	1+1	1+1	1+1	1+1	1+1	1+1	1+1	1+1	1+1	1+1	1+1	
		Outer					2	2	2	0	0	0	0	0	0	0	0	0	0	0	0	0	0	0	0	0	0	0	0	0		
5		Thin	Inner								0+0	1+0	1+1	1+2	2+2	3+3	0	1+0	1+1	2+2	2+2	3+3	4+0	4+1	1+1	1+2	2+3	3+0	4+4	4+1		
			Outer								8	7	6	5	4	2	8	7	6	4	4	2	4	3	6	4	3	5	0	3		
	Thick	Inner								0+0	0+0	0+0	0+0	0+0	0+0	0+0	0+0	0+0	0+0	0+0	0+0	0+0	0+1	0+1	1+1	1+1	1+1	1+2	1+1	1+2		
		Outer								3	3	3	3	3	3	3	3	3	3	3	3	3	2	2	1	1	1	0	1	0		
	Thick L	Inner								0+0	0+0	0+0	0+0	0+0	0+0	1+1	1+1	1+1	1+1	1+1	1+1	1+1	1+1	1+1	1+1	1+1	1+1	1+1	1+1	1+1		
		Outer								2	2	2	2	2	2	0	0	0	0	0	0	0	0	0	0	0	0	0	0	0		
8 thru 20	Thin	Inner																						1+1	1+2	1+2	2+3	3+3	4+4	1+1	1+2	
		Outer																						6	5	5	3	2	0	6	5	
	Thick	Inner																						1+1	1+1	1+1	1+1	1+1	1+1	2+2	2+2	
		Outer																						4	4	4	4	4	4	2	2	
	Fixing	Inner																						—	—	—	—	—	—	—	—	
		Outer																						—	—	—	—	—	—	—	—	

Table 3-2 Number of Adjusting Spacers (continued)

Beam Flange Width (in)	Cap. (Ton)	Spacer Type (mm)	7 1/16	7 1/4	7 7/8	8	8 7/16	8 11/16	9	9 3/8	9 7/8	10	10 1/8	10 1/4	10 3/8	10 1/2	11	11 1/8	11 1/4	11 3/8	11 5/8	11 3/4	11 13/16	11 7/8	12		
			180	184	200	203	215	220	229	232	250	254	257	260	264	267	279	283	286	289	295	298	300	302	305		
			181	185																							
1	Thin	Inner	1+1	1+2	4+4	5+0	2+3	3+4	1+1	1+2	4+0	1+1	1+2	2+2	2+3	3+3	1+1	1+2	2+2	2+3	3+0	4+0	4+1	4+1	4+2		
		Outer	6	5	0	3	3	1	6	5	4	6	5	4	3	2	6	5	4	3	5	4	3	3	2		
	Thick	Inner	0+0	0+0	0+0	0+1	1+1	1+1	2+2	2+2	2+3	3+3	3+3	3+3	3+3	3+3	4+4	4+4	4+4	4+4	4+5	4+5	4+5	4+5	4+5	4+5	
		Outer	9	9	9	8	7	7	5	5	4	3	3	3	3	3	1	1	1	1	0	0	0	0	0		
	Fixing	Inner	1+1	1+1	1+1	1+1	1+1	1+1	1+1	1+1	1+1	1+1	1+1	1+1	1+1	1+1	1+1	1+1	1+1	1+1	1+1	1+1	1+1	1+1	1+1	1+1	
		Outer	0	0	0	0	0	0	0	0	0	0	0	0	0	0	0	0	0	0	0	0	0	0	0	0	
	Thick L	Inner	1+1	1+1	1+1	1+1	1+1	1+1	1+1	1+1	1+1	1+1	1+1	1+1	1+1	1+1	1+1	1+1	1+1	1+1	1+1	1+1	1+1	1+1	1+1	1+1	
		Outer	0	0	0	0	0	0	0	0	0	0	0	0	0	0	0	0	0	0	0	0	0	0	0	0	
	2 and 3	Thin	Inner	1+1	1+2	4+4	1+0	2+3	3+3	4+1	1+1	4+4	4+1	5+1	4+3	2+3	3+3	4+1	1+2	2+2	2+3	3+3	3+4	4+4	4+1	5+1	
			Outer	6	5	0	7	3	2	3	6	0	3	2	1	3	2	3	5	4	3	2	1	0	3	2	
		Thick	Inner	0+0	0+0	0+0	1+1	1+1	1+1	1+2	2+2	2+2	2+3	2+3	2+3	3+3	3+3	3+4	4+4	4+4	4+4	4+4	4+4	4+4	4+4	4+5	4+5
			Outer	9	9	9	7	7	7	6	5	5	4	4	4	3	3	2	1	1	1	1	1	1	0	0	
Fixing		Inner	1+1	1+1	1+1	1+1	1+1	1+1	1+1	1+1	1+1	1+1	1+1	1+1	1+1	1+1	1+1	1+1	1+1	1+1	1+1	1+1	1+1	1+1	1+1	1+1	
		Outer	0	0	0	0	0	0	0	0	0	0	0	0	0	0	0	0	0	0	0	0	0	0	0	0	
Thick L		Inner	1+1	1+1	1+1	1+1	1+1	1+1	1+1	1+1	1+1	1+1	1+1	1+1	1+1	1+1	1+1	1+1	1+1	1+1	1+1	1+1	1+1	1+1	1+1	1+1	
		Outer	0	0	0	0	0	0	0	0	0	0	0	0	0	0	0	0	0	0	0	0	0	0	0	0	
5		Thin	Inner	1+0	1+1	4+4	1+0	2+3	3+4	1+1	1+2	4+4	1+1	1+2	2+2	2+3	3+3	5+1	1+2	2+2	2+3	4+3	4+4	4+0	4+1	5+1	
			Outer	7	6	0	7	3	1	6	5	0	6	5	4	3	2	2	5	4	3	1	0	4	3	2	
		Thick	Inner	2+2	2+2	2+2	3+3	3+3	3+3	4+4	4+4	4+4	5+5	5+5	5+5	5+5	5+5	5+6	6+6	6+6	6+6	6+6	6+6	6+7	6+7	6+7	
			Outer	0	0	9	7	7	7	5	5	5	3	3	3	3	3	2	1	1	1	1	1	0	0	0	
	Thick L	Inner	1+1	1+1	1+1	1+1	1+1	1+1	1+1	1+1	1+1	1+1	1+1	1+1	1+1	1+1	1+1	1+1	1+1	1+1	1+1	1+1	1+1	1+1	1+1		
		Outer	0	0	0	0	0	0	0	0	0	0	0	0	0	0	0	0	0	0	0	0	0	0	0		
8 thru 20	Thin	Inner	2+2	2+3	1+1	1+2	3+3	4+4	1+1	1+2	4+4	1+1	1+2	2+2	2+3	3+3	1+1	1+2	2+2	2+3	3+4	4+0	4+0	4+1	5+1		
		Outer	4	3	6	5	2	0	6	5	0	6	5	4	3	2	6	5	4	3	1	4	4	3	2		
	Thick	Inner	2+2	2+2	3+3	3+3	3+3	3+3	1+1	1+1	1+1	2+2	2+2	2+2	2+2	2+2	3+3	3+3	3+3	3+3	3+3	3+4	3+4	3+4	3+4		
		Outer	2	2	0	0	0	0	5	5	5	3	3	3	3	3	1	1	1	1	1	0	0	0	0		
	Fixing	Inner	—	—	—	—	—	—	1+1	1+1	1+1	1+1	1+1	1+1	1+1	1+1	1+1	1+1	1+1	1+1	1+1	1+1	1+1	1+1	1+1		
		Outer	—	—	—	—	—	—	0	0	0	0	0	0	0	0	0	0	0	0	0	0	0	0	0		

- 3.1.7 Counter Weight – For proper balance 1 Ton, dual speed MR2 trolleys (code MR2010SD) require a Counter Weight when installed on a 3 7/8 inch or smaller beam flange. The Counter Weight mounts on the Suspension Shaft as shown in Figure 3-11 and is held in place with a Bolt, Slotted Nut and Split Pin. The bolt is installed through holes B and C. Make sure the weight is securely fastened to the shaft and that the split pin is properly bent. All other trolley capacities do NOT require a counter weight.

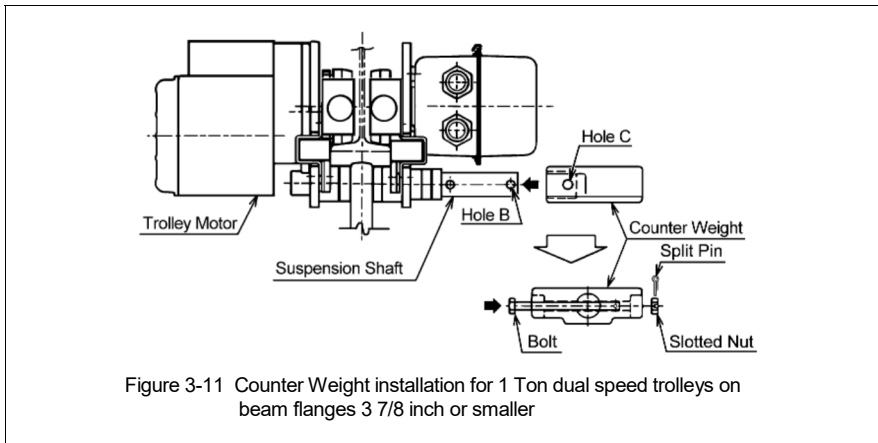

3.2 Mounting Location

- 3.2.1 **⚠ WARNING** Prior to mounting the trolley (and hoist) ensure that the trolley beam and its supporting structure are adequate to support the trolley, hoist and its loads. If necessary consult a professional that is qualified to evaluate the adequacy of the suspension location and its supporting structure.
- 3.2.2 **NOTICE** See Section 6.5 for outdoor installation considerations.

3.3 Installation of Trolley onto Beam

- 3.3.1 Assemble and adjust the trolley before attempting to install the trolley on the beam.
- 3.3.2 Preferred Method – Sliding the trolley connected with an electric chain hoist onto the traversing beam from the beam end is the most convenient and recommended method. If the trolley can be mounted from the end of the beam then: Remove the trolley end-stop from the beam and set the trolley on the beam from the end. Securely re-install the trolley end stop on the beam.
- 3.3.3 Optional Method for Trolleys Up to 5 Ton – If the trolley cannot be mounted from the end of the beam, complete the installation as follows:
- 1) Move the Shaft Stopper Pin to Hole B (see Figure 3-12).
 - 2) Spread the trolley side plates apart.
 - 3) Lift the trolley onto the beam so that the geared wheels (motor side of trolley) rest on the beam's flange.
 - 4) Hold Side Plate G securely so that it does not come off the beam then push the side plates together so that all four wheels rest on the beam's flange.
 - 5) Remove the Shaft Stopper Pin from Hole B and re-install in Hole A (see Figure 3-5). Bend the Split Pin securely. Never use trolley with Shaft Stopper Pin in Hole B. Hole B is ONLY used when installing the trolley on the beam.

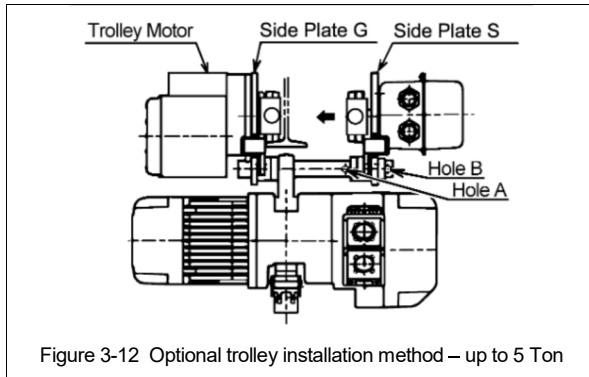
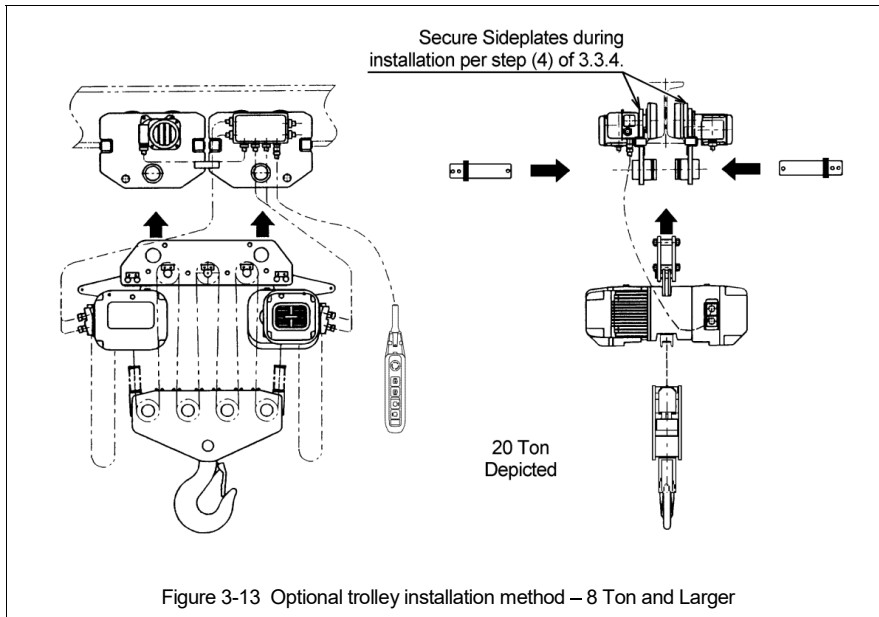

Figure 3-12 Optional trolley installation method – up to 5 Ton

3.3.4 Optional Method for 8 to 20 Ton Trolley with hoist - refer to Figure 3-13.

▲WARNING ALWAYS install the trolley onto the beam before installing the hoist to the trolley. Attempting to install a pre-assembled hoist and trolley onto the beam other than onto the beam end (per Section 3.3.2) is dangerous and must not be attempted.

- 1) Assemble and adjust the trolley.
- 2) Separate the trolley from the hoist by removing the Suspension Shaft(s), Adjusting spacers and Trolley Fixing Shaft (8 and 10 Ton only). Reassemble the trolley without the hoist by reinstalling the Suspension Shaft(s), Trolley Fixing Shaft and outer Adjusting Spacers. Place inner spacers aside until step (6).
- 3) Install the trolley on the beam by following steps (1) to (5) of Section 3.3.3.
- 4) Use safe and proper rigging practices to secure the trolley side plates so that they will remain firmly in place after the Suspension Shaft(s) and Trolley Fixing Shaft are removed (next step).
- 5) Remove the Suspension Shaft(s), Trolley Fixing Shaft and outer Adjusting Spacers.
- 6) Move the hoist up into position between the trolley side plates and line up the trolley and hoist's Suspension Shaft holes.
- 7) Connect the hoist to the trolley by reinstalling the Suspension Shaft(s), Trolley Fixing Shaft, Adjusting Spacers, Suspension Shaft Bolt(s), and Shaft Stopper Pin(s).
- 8) Ensure that:
 - Shaft Stopper Pin(s) is(are) in hole A of the Suspension Shaft(s).
 - Split Pins are installed properly.
 - Trolley is properly adjusted (refer to Section 3.1.6).



3.4 Electrical Connections

- 3.4.1 **▲▲ CAUTION** Ensure that the voltage of the electric power supply is proper for the hoist or trolley.
- 3.4.2 **▲▲ CAUTION** Do NOT apply electronic soft-start control or voltage varying controls to the MR2 trolley. Use of such devices may cause the motor brake and other electrical components to malfunction. Variable frequency drives MAY be used with single speed MR2 trolleys, contact Harrington Hoists, Inc. for more information.
- 3.4.3 **▲▲ DANGER** Before proceeding, ensure that the electrical supply for the hoist or trolley has been de-energized (disconnected). Lock out and tag out in accordance with ANSI Z244.1 "Personnel Protection -Lockout/Tagout of Energy Sources".
- 3.4.4 **▲▲ DANGER** To avoid a shock hazard, **DO NOT** perform **ANY** mechanical or electrical maintenance on the dual speed (or VFD control) trolley or hoist within 5 minutes of de-energizing (disconnecting) the trolley or hoist. This time allows the internal VFD capacitor to safely discharge.
- 3.4.5 **▲▲ DANGER** Do Not remove power to the dual speed (or VFD control) hoist or trolley during operation.
- 3.4.6 **▲▲ CAUTION** All dual speed trolleys are equipped with a VFD. The VFD is used to control the high and low traversing speeds and accelerations. These speeds and accelerations come preset from the factory, 80/13 feet per minute. Speed (frequency) and acceleration/deceleration time parameters can be customized. Refer to Section 3.5.10 for trolley specific speed ranges and instructions and Section 3.5.11 for trolley specific acceleration/deceleration ranges and instructions.

- 3.4.7 The following instructions apply to installations where an ER2 or NER2 model electric hoist is installed on an MR2 trolley. In this case the hoist and trolley are controlled by a pendant with four push buttons – two for the hoist motion and two for the trolley motion. Special wiring considerations must be taken if the trolley is used with a hoist other than an ER2 or NER2 model.

Pendant Cord - The Pendant Cord connects to the trolley via an 8-pin (8P) Plug and Socket. Make this connection as follows:

- 1) Refer to Figure 3-14 or 3-15 depending on the product code of the trolley/hoist.
- 2) Insert the 8P Plug into the 8P Socket on the Switch Box and hand tighten the Screw Coupling.
- 3) For trolley/hoist code ER2/NER2M001H to ER2/NER2M100L – Install the Cord Strain Relief Cable to the Cord Support on the Bar Holder.
- 4) For trolley/hoist code ER2/NER2M100S – install the Cord Strain Relief Cable onto Cord Strain Relief Stopper located at the 8P socket.
- 5) For trolley/hoist code ER2/NER2M150S and ER2/NER2M200S – Install the Cord Strain Relief Cable onto Connection Plate S.

Power Supply Cable Hoist Connection – The Power Supply Cable connects directly to the trolley's Switch Box using Cable Holder Assembly. Make this connection as follows:

- 1) Refer to Figure 3-14 or 3-15 depending on the product code of the trolley/hoist.
- 2) With 1 inch of the outer cable insulation extending beyond the cable packing, insert the cable into the switch box and screw together Cable Holder A and B.
- 3) Refer to Figure 3-16 and connect the red, blue and black wires to terminals 1, 2, and 3 on the terminal strip inside the Switch Box. Connect the ground wire (green with yellow stripe or solid green) to the ground terminal next to the terminal strip.
- 4) Install the Cable Support Assembly (pre-installed on the Power Supply Cable) onto the Cable Support Arm Assembly as shown in Figure 3-17.
- 5) Use care to avoid twisting or kinking the Power Supply Cable.

Trolley to Hoist Connections – The trolley connects to the hoist via short cables that are factory installed into the trolley Switch Box. The Cables are fitted with plug assemblies that match sockets in the hoist bodies. Make these connections as follows:

- 1) Refer to Figure 3-14 or 3-15 depending on the product code of the trolley/hoist.
- 2) Insert the 4P Plug(s) into the 4P Socket(s) on the hoist and hand tighten the Screw Coupling(s).
- 3) Insert the 5P Plug(s) into the 5P Socket(s) on the hoist and hand tighten the Screw Coupling(s).

Power Supply Cable Festooning – The MR2 trolley is supplied with Cable Hangers for the Power Supply Cable. Make this connection as follows:

- 1) Refer to Figure 3-17.
- 2) Install the Cable Hangers onto the Power Supply Cable spacing them every 5 feet.
- 3) Install a Guide Wire system parallel to the beam. Pass the Guide Wire through the Cable Hangers and Wire Guide.
- 4) Make sure the Guide Wire is properly tensioned and the Power Supply Cable is not twisted or kinked.

- 3.4.8 Connection to Electrical Power Source - The red, blue and black wires of the Power Supply Cable should be connected to an Electric Power Disconnect Switch or Circuit Breaker. This connection should be made so that the ER2/NER2 or other hoist is phased properly. Refer to Section 3.6.5 for instructions on how to check for correct power supply phase connection.
- 3.4.9 Fuse/Breaker Capacity -The power supply for the trolley and hoist should be equipped with current overload protection such as fuses, which should be selected for 110% to 120% of total listed full load amperage, and should be dual element time-delay fuses. Refer to the motor nameplates on the trolley and hoist for the full load amperage draw of each and added the two values together for the total amperage.
- 3.4.10 **▲▲ DANGER** Grounding - An improper or insufficient ground connection creates an electrical shock hazard when touching any part of the hoist or trolley. In the Power Supply Cable the ground wire will be either Green with Yellow stripe or solid Green. It should always be connected to a suitable ground connection. Do not paint the trolley wheel running surfaces of the beam as this can affect grounding.

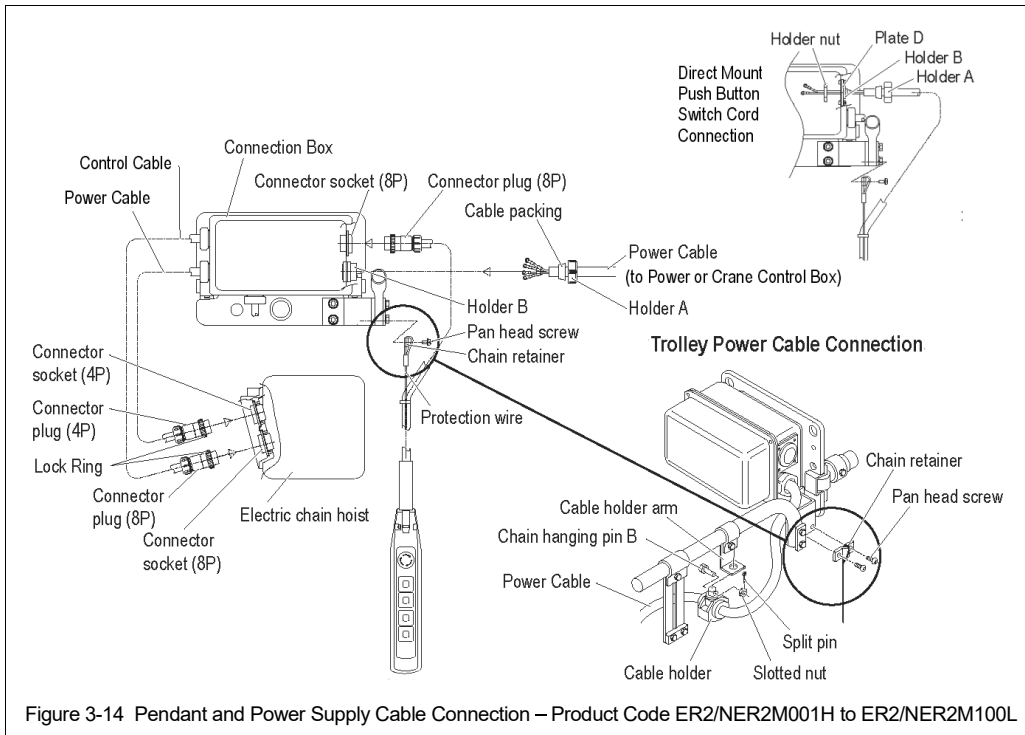

Figure 3-14 Pendant and Power Supply Cable Connection – Product Code ER2/NER2M001H to ER2/NER2M100L

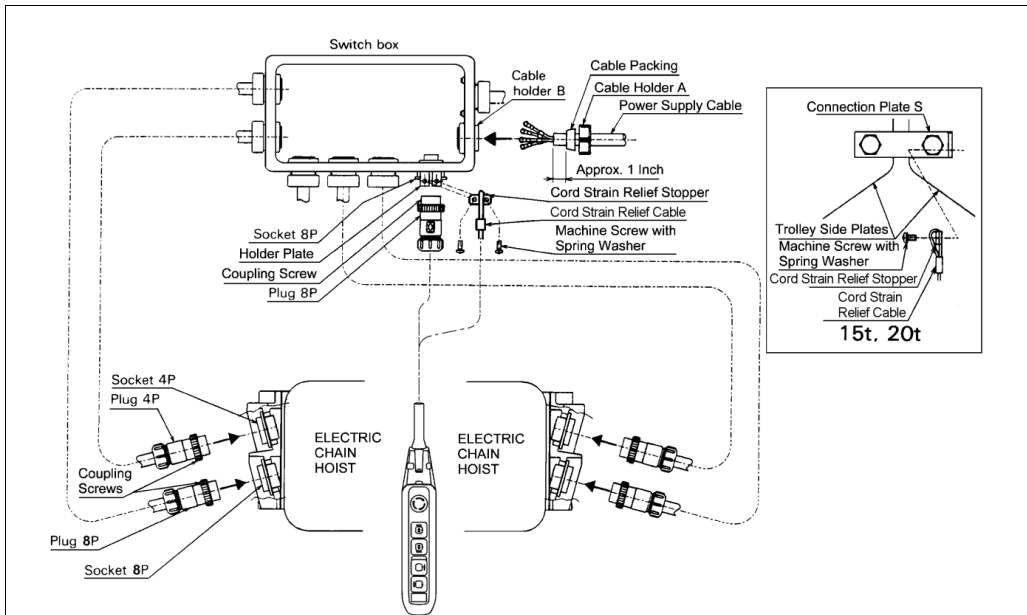

Figure 3-15 Pendant and Power Supply Cable Connection - Product Code ER2/NER2M100S to ER2/NER2M200S

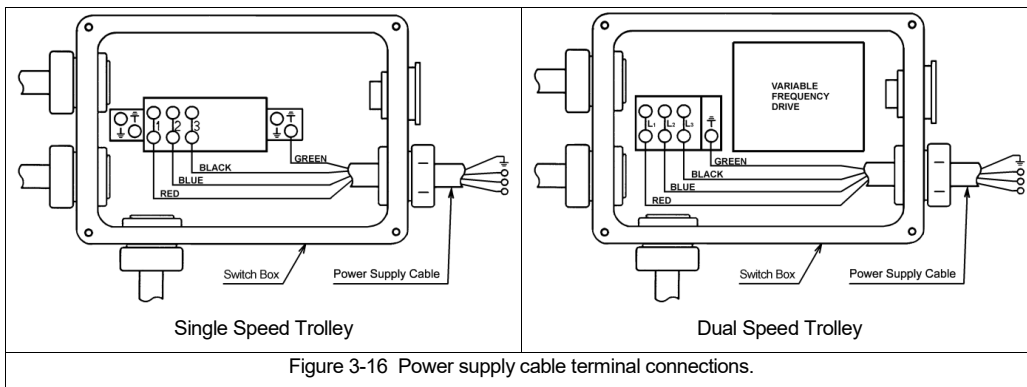

Figure 3-16 Power supply cable terminal connections.

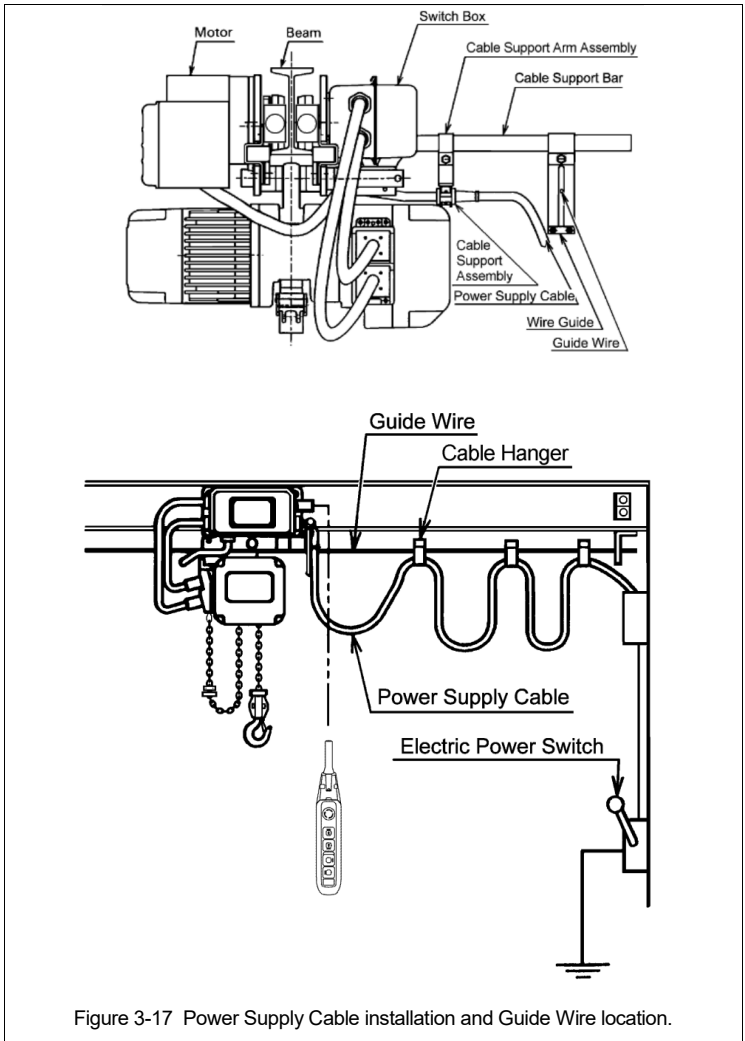
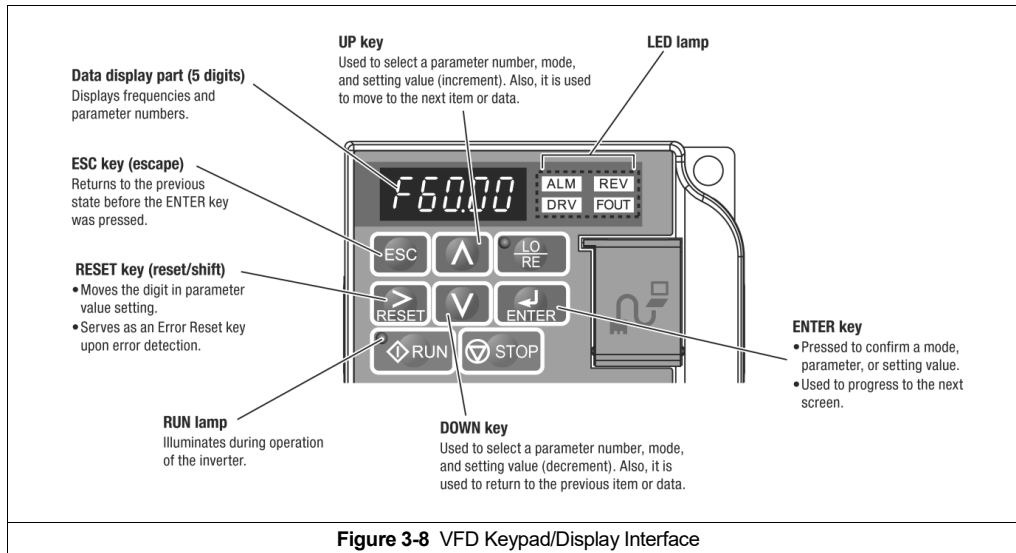

Figure 3-17 Power Supply Cable installation and Guide Wire location.



3.5 VFD Setup (Dual Speed Only)

- 3.5.1 **⚠ DANGER** To avoid a shock hazard, **DO NOT** perform **ANY** mechanical or electrical maintenance on the dual speed (or VFD control) trolley or hoist within 5 minutes of de-energizing (disconnecting) the trolley or hoist. This time allows the internal VFD capacitor to safely discharge.
- 3.5.2 **⚠ WARNING** Do Not remove power to the hoist or trolley during operation.
- 3.5.3 All dual speed trolleys are equipped with a VFD. The VFD is used to control the high and low speeds and the accelerations/decelerations (accel/decel) of the trolley. These speeds, 80/13 and acceleration/decelerations, 4.0 seconds come preset from the factory. Speed (frequency) and acceleration/deceleration time parameters can be customized. Refer to Section 3.5.6 for trolley specific speed ranges and instructions and Section 3.5.7 for trolley specific acceleration/deceleration parameters and instructions.
- 3.5.4 The VFD is controlled by a Keypad/Display Interface. Refer to Figure 3-8 for Keypad/Display Interface functions and descriptions.



3.5.5 When power is supplied to the trolley the VFD LED operator display will illuminate as shown Table 3-3.

Table 3-3 LED Operator Display

No	Name	Description
Normal		The frequency command monitor is displayed in the data display part. DRV illuminates.
Error	 Example: Main circuit low voltage	The display varies depending on the error. ALM and DRV illuminate.

3.5.6 During operation the data display will exhibit illuminating or blinking data as shown in Figure 3-9.

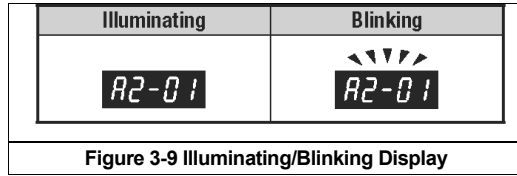





3.5.7 The digital display uses a seven segment character to form the specific characters used in the display. Table 3-4 shows the corresponding digital characters to its English equivalent.

Character	Digital Display	Character	Digital Display	Character	Digital Display	Character	Digital Display
0	0	9	9	l	l	R	ρ
1	1	A	A	J	9	S	Σ
2	2	B	β	K	τ	T	Γ
3	3	C	X	L	Λ	U	Υ
4	4	D	δ	M	∩	V	ω
5	5	E	E	N	N	W	ω
6	6	F	Φ	O	o	X	No Display
7	7	G	Γ	P	Π	Y	Ψ
8	8	H	H	Q	θ	Z	No Display

3.5.8 The LED Lamp display provides trolley status. Table 3-5 shows some of the status displays.

Lamp	Illuminating	Blinking	Off
ALM	Upon error detection	<ul style="list-style-type: none"> Upon detection of minor failure Upon detection of an OPE (operation error) 	Normal
REV	Inputting a reverse rotation command	-	Inputting a forward rotation command
DRV	In the drive mode	-	In the program mode
FOUT	Displaying output frequency (Hz)	-	-
Description in this document			

3.5.9 The Run Lamp display provides trolley “RUN” status. Table 3-6 shows the various “RUN” displays.

Lamp	Illuminating	Blinking	Short blinking	Off
	During operation	<ul style="list-style-type: none"> • During deceleration/ stop • Inputting a driving command with the frequency command 0 	<ul style="list-style-type: none"> • During deceleration due to an emergency stop • During deceleration • During a stop due to driving interlock operation 	During a stop
Description in this document				

3.5.10 All of the dual speed trolleys have speed/frequency ranges that can be customized to a specific application. Refer to Table 3-7 for specific trolley speed/frequency ranges. To set custom speeds for an application, follow the procedure in Table 3-8.

Product Code	Trolley Speed (ft/min)			VFD Frequency (Hz)			
	Range*	Low	High	Low (d1-01)		High (d1-02)	
				230V	460V	230V	460V
MR2010SD	Low	8.0	80.0	6.7	6.7	63.0	63.0
	Std	13.0	80.0	11.0	11.0	63.0	63.0
MR2020SD	Low	8.0	80.0	6.7	6.7	63.0	63.0
	Std	13.0	80.0	11.0	11.0	63.0	63.0
MR2030SD	Low	8.0	80.0	6.7	6.7	63.0	63.0
	Std	13.0	80.0	11.0	11.0	63.0	63.0
MR2050SD	Low	8.0	80.0	6.7	6.7	63.0	63.0
	Std	13.0	80.0	11.0	11.0	63.0	63.0

*Low = The minimum and maximum speed/frequency range (10:1 ratio).

Std = The factory standard minimum and maximum speed/frequency range (6:1 ratio).

Table 3-8 Dual Speed Trolley (w/VFD) Speed/Frequency Change Procedure

⚠ CAUTION

- Each dual speed trolley has a range of available speeds/frequencies (upper and lower limits). Any value outside the range listed in Table 3-7 for your specific trolley is strictly prohibited.
- Speeds must be set such as Low [d1-01] and High [d1-02].
- After parameters are changed, a “no load” operational check must be performed.

Operational Step	VFD Display
1. Energize the trolley.	
2. Press until the “Setup Mode” screen is displayed (blinking).	
3. Press to display the parameter setting screen (blinking).	
4. Press or until the desired parameter is displayed (blinking). (Low Speed: d1-01, High Speed: d1-02)	
5. When you press , the current setting value is displayed (digit selected blinks). (Example Value: 9Hz)	
6. Press to move the blinking digit to the desired digit. (Example Value: 9 blinks)	
7. Press or until the desired setting is displayed and press . (Example Value: 8Hz)	
8. Press to confirm the new setting.	
9. The display will automatically return to the parameter screen (blinking). (As in Step 4.)	
10. Press until the display returns to the initial screen. (As in Step 1.)	

3.5.11 All dual speed trolleys have a acceleration/deceleration time parameter range that can be customized to a specific application. Refer to Table 3-9 for specific trolley acceleration/deceleration time ranges. To set custom acceleration/deceleration times for an application, follow the procedure in Table 3-10.







Table 3-9 VFD Acceleration/Deceleration Time Parameter Ranges

Item	Parameter No.	Initial Value	Unit	Setting Range	Remark
Acceleration Time	C1-01	4.0	Seconds	1.2 – 6.0	Set the same value to the two parameters
	C1-03				
Deceleration Time	C1-02	4.0	Seconds	1.2 – 6.0	Set the same value to the two parameters
	C1-04				

Table 3-10 Trolley VFD 2-Step/3-Step Infinitely Variable Parameter Setup Procedure

⚠ CAUTION

- Each dual speed trolley model has a range of available speeds/frequencies (upper and lower limits) and acceleration/deceleration time parameters. Refer to Owner's Manual MOTORIZED TROLLEY MR2 SERIES.
- Any value outside the range listed in Table 3-7 for your specific trolley is strictly prohibited.
- Speeds must be set such as Low [d1-01] and High [d1-02].
- After parameters are changed, a "no load" operational check must be performed.

Operational Step		VFD Display
Change Mode to 2 Step or 3 Step.		
1. Press  or  until the "Setup Mode" screen is displayed (blinking).		
2. Press  to display "d1-01".		
3. Tables 3-7 and 3-9 lists the values that may be changed.		
Title	Parameter	Description
Min. Frequency (Hz) – Low Speed	d1-01	11 Hz (default setting)
Max. frequency (Hz) – High Speed	d1-02	63 Hz (default setting)
Mode	S1-25	1. Standard 2 Speed (default) 2. 2-Step Infinitely Variable 3. 3-Step Infinitely Variable
Acceleration Time (sec.) (0 to 120 Hz) in 2 or 3 Step Mode.	S1-26	Apply for frequency range between d1-01 and d1-02.
Deceleration Time (sec.) (0 to 120 Hz) in 2 or 3 Step Mode.	S1-27	Apply for frequency range between d1-01 and d1-02.
Acceleration Time (sec.) (0 to 120 Hz) in 2 speed.	C1-01	In 2 or 3 Step Mode, apply for the frequency range between starting frequency (6.6 Hz) and d1-01.
Deceleration Time (sec.) (0 to 120 Hz) in 2 speed.	C1-02	
Acceleration Time (sec.) (0 to 120 Hz) in 2 speed.	C1-03	
Deceleration Time (sec.) (0 to 120 Hz) in 2 speed.	C1-04	
4. Press  several times.		

3.5.12 "Hbb" will appear on the dual speed unit's VFD display when the Emergency Stop Button is depressed. Turn the Emergency Stop Button clockwise to unlock the controls and allow hoist operation.

3.6 Pre-operational Checks and Trial Operation

3.6.1 Refer to the trolley's Nameplate and record the Code, Lot and Serial Number in the space provided on the cover of this manual.

3.6.2 Refer to the hoist's owner's manual and perform all pre-operational checks for the hoist.

3.6.3 Perform pre-operational checks for the trolley:

- **▲▲WARNING** Confirm the adequacy of the rated capacity for all slings, chains, wire ropes and all other lifting attachments before use. Inspect all load suspension members for damage prior to use and replace or repair all damaged parts.
- Ensure that trolley is properly installed on the beam, and stops for the trolley are correctly positioned and securely installed on the beam.
- Ensure that all nuts, bolts and split pins (cotter pins) are sufficiently fastened.
- Pull down on the Pendant and ensure that the Cord Strain Relief Cable takes the force, not the Pendant Cord.
- **▲▲CAUTION** Check supply voltage before everyday use. If the voltage varies more than 10% of the rated value, electrical devices may not function normally.

3.6.4 Confirm proper operation.

- Before operating read and become familiar with Section 4 - Operation.
- Before operating ensure that the hoist (and trolley) meets the Inspection, Testing and Maintenance requirements of ANSI/ASME B30.16.
- Before operating ensure that nothing will interfere with the full range of the hoist's (and trolley's) operation.

3.6.5 Proceed with trial operation to confirm proper operation.

- Verify that the controls agree with hoist direction. Make sure that depression of the Up button lifts the load chain and hook and depression of the Down button lowers the load chain and hook. If the load chain and hook does not move in the correct direction when the push buttons are pushed, the power supply is phased incorrectly. In this case, turn off the power source or breaker switch then reverse any two of the three wires at the power source. The hook will then move in accordance with the directions of the push button.
- Operate the trolley through its full range of motion. Make sure the trolley runs smoothly and does not bind. Check the power supply and festoon system for proper operation
- Perform inspections per Section 5.3, "Frequent Inspections".

4.0 Operation

4.1 Introduction

DANGER

DO NOT WALK UNDER A SUSPENDED LOAD

WARNING

HOIST OPERATORS SHALL BE REQUIRED TO READ THE OPERATION SECTION OF THIS MANUAL, THE WARNINGS CONTAINED IN THIS MANUAL, INSTRUCTION AND WARNING LABELS ON THE HOIST OR LIFTING SYSTEM, AND THE OPERATION SECTIONS OF ANSI/ASME B30.16 and ANSI/ASME B30.10. THE OPERATOR SHALL ALSO BE REQUIRED TO BE FAMILIAR WITH THE HOIST AND HOIST CONTROLS BEFORE BEING AUTHORIZED TO OPERATE THE HOIST OR LIFTING SYSTEM.

HOIST OPERATORS SHOULD BE TRAINED IN PROPER RIGGING PROCEDURES FOR THE ATTACHMENT OF LOADS TO THE HOIST HOOK.

HOIST OPERATORS SHOULD BE TRAINED TO BE AWARE OF POTENTIAL MALFUNCTIONS OF THE EQUIPMENT THAT REQUIRE ADJUSTMENT OR REPAIR, AND TO BE INSTRUCTED TO STOP OPERATION IF SUCH MALFUNCTIONS OCCUR, AND TO IMMEDIATELY ADVISE THEIR SUPERVISOR SO CORRECTIVE ACTION CAN BE TAKEN.

HOIST OPERATORS SHOULD HAVE NORMAL DEPTH PERCEPTION, FIELD OF VISION, REACTION TIME, MANUAL DEXTERITY, AND COORDINATION.

HOIST OPERATORS SHOULD **NOT** HAVE A HISTORY OF OR BE PRONE TO SEIZURES, LOSS OF PHYSICAL CONTROL, PHYSICAL DEFECTS, OR EMOTIONAL INSTABILITY THAT COULD RESULT IN ACTIONS OF THE OPERATOR BEING A HAZARD TO THE OPERATOR OR TO OTHERS.

HOIST OPERATORS SHOULD **NOT** OPERATE A HOIST OR LIFTING SYSTEM WHEN UNDER THE INFLUENCE OF ALCOHOL, DRUGS, OR MEDICATION.

OVERHEAD HOISTS ARE INTENDED ONLY FOR VERTICAL LIFTING SERVICE OF FREELY SUSPENDED UNGUIDED LOADS. DO **NOT** USE HOIST FOR LOADS THAT ARE NOT LIFTED VERTICALLY, LOADS THAT ARE NOT FREELY SUSPENDED, OR LOADS THAT ARE GUIDED.

NOTICE

- Read ANSI/ASME B30.16 and ANSI/ASME B30.10.
- Read the hoist manufacturer's Operating and Maintenance Instructions.
- Read all labels attached to equipment.

The operation of an overhead hoist involves more than activating the hoist's controls. Per the ANSI/ASME B30 standards, the use of an overhead hoist is subject to certain hazards that cannot be mitigated by engineered features, but only by the exercise of intelligence, care, common sense, and experience in anticipating the effects and results of activating the hoist's controls. Use this guidance in conjunction with other warnings, cautions, and notices in this manual to govern the operation and use of your overhead hoist.

4.2 Shall's and Shall Not's for Operation

WARNING

Improper operation of a hoist can create a potentially hazardous situation which, if not avoided, could result in death or serious injury, and substantial property damage. To avoid such a potentially hazardous situation **THE OPERATOR SHALL:**

- **NOT** operate a damaged, malfunctioning or unusually performing hoist.
- **NOT** operate a hoist until you have thoroughly read and understood Manufacturer's Operating and Maintenance Instructions or Manuals.
- Be familiar with operating controls, procedures, and warnings.
- **NOT** operate a hoist that has been modified without the manufacturer's approval or without certification that it is in conformity with ANSI/ASME B30 volumes.
- **NOT** lift more than rated load for the hoist.
- **NOT** use hoist with twisted, kinked, damaged, or worn load chain.
- **NOT** use the hoist to lift, support, or transport people.
- **NOT** lift loads over people.
- **NOT** operate a hoist unless all persons are and remain clear of the supported load.
- **NOT** operate unless load is centered under hoist.
- **NOT** attempt to lengthen the load chain or repair damaged load chain.
- Protect the hoist's load chain from weld splatter or other damaging contaminants.
- **NOT** operate hoist when it is restricted from forming a straight line from hook to support in the direction of loading.
- **NOT** use load chain as a sling or wrap load chain around load.
- **NOT** apply the load to the tip of the hook or to the hook latch.
- **NOT** apply load unless the load chain is properly seated in its grooves.
- **NOT** apply load if bearing prevents equal loading on all load-supporting chain.
- **NOT** operate beyond the limits of the load chain travel.
- **NOT** leave load supported by the hoist unattended unless specific precautions have been taken.
- **NOT** allow the load chain or hook to be used as an electrical or welding ground.
- **NOT** allow the load chain or hook to be touched by a live welding electrode.
- **NOT** remove or obscure the warnings on the hoist.
- **NOT** operate a hoist on which the safety placards or decals are missing or illegible
- **NOT** operate a hoist unless it has been securely attached to a suitable support.
- **NOT** operate a hoist unless load slings or other approved single attachments are properly sized, and seated in the hook saddle.
- **NOT** use the hoist in such a way that could result in shock or impact loads being applied to the hoist.
- Take up slack carefully – make sure load is balanced and load-holding action is secure before continuing.
- Shut down a hoist that malfunctions or performs unusually and report such malfunction.
- Make sure hoist limit switches function properly.
- Warn personnel before lifting or moving a load.
- Warn personnel of an approaching load.

CAUTION

Improper operation of a hoist can create a potentially hazardous situation which, if not avoided, could result in minor or moderate injury, or property damage. To avoid such a potentially hazardous situation **THE OPERATOR SHALL:**

- Maintain a firm footing or be otherwise secured when operating the hoist.
- Check brake function by tensioning the hoist prior to each lift operation.
- Use hook latches. Latches are to retain slings, chains, etc. under slack conditions only.
- Make sure the hook latches are closed and not supporting any parts of the load.
- Make sure the load is free to move and will clear all obstructions.
- Avoid swinging the load or hook.
- Make sure hook travel is in the same direction as shown on controls.
- Inspect the hoist regularly, replace damaged or worn parts, and keep appropriate records of maintenance.
- Use the hoist manufacturer's recommended parts when repairing the unit.
- Lubricate load chain per hoist manufacturer's recommendations.
- **NOT** use the hoist load limiting or warning device to measure load.
- **NOT** use limit switches as routine operating stops. They are emergency devices only.
- **NOT** allow your attention to be diverted from operating the hoist.
- **NOT** allow the hoist to be subjected to sharp contact with other hoists, structures, or objects through misuse.
- **NOT** adjust or repair the hoist unless qualified to perform such adjustments or repairs.

4.3 Trolley and Hoist Controls

- 4.3.1 Emergency Stop Button – Press the Emergency Stop Button to perform an emergency stop and lock-out of hoist motion controls or to reset the VFD as shown in Figure 4-1. Turn the Emergency Stop Button clockwise to unlock the controls and allow hoist operation. “Hbb” will appear on the dual speed unit’s VFD display when the Emergency Stop Button is depressed.
- 4.3.2 Single Speed Pendant Control - When using the pendant control depress the Up button to raise the hoist’s hook or the Down button to lower the hoist’s hook as shown in Figure 4-1. Depress the Forward and Reverse buttons to move the trolley horizontally. To stop motion release the buttons.
- 4.3.3 Dual Speed Pendant Control – Pendant controls supplied with dual speed hoists or trolleys have two step control buttons. For low speed depress the button to the first step and for high speed depress the button fully to the second step. Use the Up button to raise the hoist’s hook or the Down button to lower the hoist’s hook as shown in Figure 4-1. Depress the Forward and Reverse buttons to move the trolley horizontally. To stop motion release the buttons.
- 4.3.4 Trolley with Two Button Pendant – When a motorized trolley is supplied with a two button pendant, the pendant buttons control the trolley’s horizontal motion in the forward and reverse directions. Single and dual speed buttons function identical to the four button pendant described above.
- 4.3.5 **CAUTION** Make sure the hoist and/or trolley motor completely stops before reversing direction.

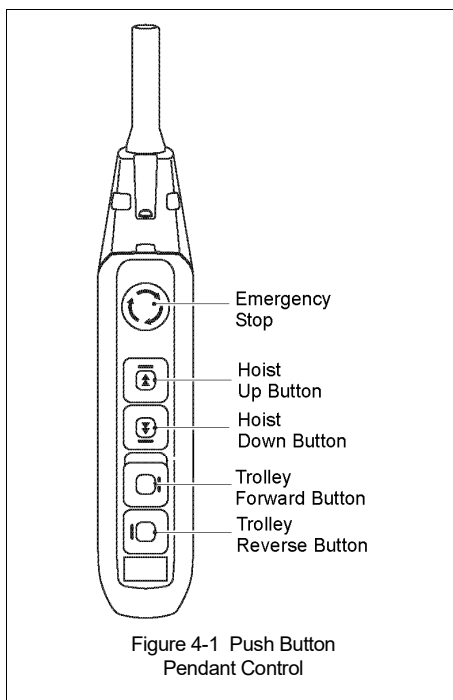

5.0 Inspection

5.1 General

- 5.1.1 The inspection procedure herein is based on ANSI/ASME B30.16. The following definitions are from ANSI/ASME B30.16 and pertain to the inspection procedure below.
- **Designated Person** - a person selected or assigned as being competent to perform the specific duties to which he/she is assigned.
 - **Qualified Person** - a person who, by possession of a recognized degree or certificate of professional standing, or who, by extensive knowledge, training, and experience, has successfully demonstrated the ability to solve or resolve problems relating to the subject matter and work.
 - **Normal Service** - that distributed service which involves operation with randomly distributed loads within the rated load limit, or uniform loads less than 65% of rated load for not more than 25% of the time.
 - **Heavy Service** - that service which involves operation within the rated load limit which exceeds normal service.
 - **Severe Service** - that service which involves normal or heavy service with abnormal operating conditions.

5.2 Inspection Classification

- 5.2.1 Initial Inspection - prior to initial use, all new, re-installed, altered, or modified trolleys shall be inspected by a designated person to ensure compliance with the applicable provisions of this manual.
- 5.2.2 Inspection Classification - the inspection procedure for trolleys in regular service is divided into two general classifications based upon the intervals at which inspection should be performed. The intervals in turn are dependent upon the nature of the critical components of the trolley and the degree of their exposure to wear, deterioration, or malfunction. The two general classifications are herein designated as FREQUENT and PERIODIC, with respective intervals between inspections as defined below.
- 5.2.3 FREQUENT Inspection - visual examinations by the operator or other designated personnel with intervals per the following criteria:
- Normal service - monthly
 - Heavy service - weekly to monthly
 - Severe service - daily to weekly
 - Special or infrequent service - as recommended by a qualified person before and after each occurrence.
- 5.2.4 PERIODIC Inspection - visual inspection by a designated person with intervals per the following criteria:
- Normal service - yearly
 - Heavy service - semiannually
 - Severe service – quarterly
 - Special or infrequent service - as recommended by a qualified person before the first such occurrence and as directed by the qualified person for any subsequent occurrences.

5.3 Frequent Inspection

5.3.1 Inspections should be made on a FREQUENT basis in accordance with Table 5-1, "Frequent Inspection." Included in these FREQUENT Inspections are observations made during operation for any defects or damage that might appear between Periodic Inspections. Evaluation and resolution of the results of FREQUENT Inspections shall be made by a designated person such that the trolley is maintained in safe working condition.

Table 5-1 Frequent Inspection
All functional operating mechanisms for proper operation, proper adjustment, and unusual sounds.
Trolley braking system for proper operation
Hoist(s) in accordance with ANSI/ASME B30.16
Upper Limit Devices in accordance with ANSI/ASME B30.16
Hook(s) and hook latches in accordance with ANSI/ASME B30.10

5.4 Periodic Inspection

5.4.1 Inspections should be made on a PERIODIC basis in accordance with Table 5-2, "Periodic Inspection." Evaluation and resolution of the results of PERIODIC Inspections shall be made by a designated person such that the trolley is maintained in safe working condition.

5.4.2 For inspections where load suspension parts of the trolley are disassembled, a load test per ANSI/ASME B30.16 must be performed on the trolley after it is re-assembled and prior to its return to service.

Table 5-2 Periodic Inspection
Requirements of frequent inspection.
Loose or missing bolts, nuts, pins or rivets.
Worn, cracked, or distorted parts such as pins, bearings, wheels, shafts, gears, rollers, yokes, and bumpers.
Excessive wear of brake system parts
Deterioration of electrical components such as controllers, switches, contacts, pushbuttons.
Proper function of motion limit devices that interrupt power or cause a warning to be activated.
Function, instruction and warning labels for legibility and placement.

5.5 Occasionally Used Trolleys

5.5.1 Trolleys that are used infrequently shall be inspected as follows prior to placing in service:

- Trolley Idle More Than 1 Month, Less Than 1 Year: Inspect per FREQUENT Inspection criteria in Section 5.3.
- Trolley Idle More Than 1 Year: Inspect per PERIODIC Inspection criteria in Section 5.4

5.6 Inspection Records

5.6.1 Dated inspection reports and records should be maintained at time intervals corresponding to those that apply for the hoist's PERIODIC interval per Section 5.2.4. These records should be stored where they are available to personnel involved with the inspection, maintenance, or operation of the trolley.

5.7 Inspection Methods and Criteria

5.7.1 This section covers the inspection of specific items. The list of items in this section is based on those listed in ANSI/ASME B30.16 for Frequent and Periodic Inspection. In accordance with ANSI/ASME B30.16, these inspections are not intended to involve disassembly of the trolley. Rather, disassembly for further inspection would be required if frequent or periodic inspection results so indicate. Such disassembly and further inspection should only be performed by a qualified person trained in the disassembly and re-assembly of the trolley.

Table 5-3 Trolley Inspection Methods and Criteria

Item	Method	Criteria	Action
Functional operating mechanisms.	Visual, Auditory	Mechanisms should be properly adjusted and should not produce unusual sounds when operated.	Repair or replace as required.
Braking System Operation	Function	Trolley must come to a smooth stop within 10% of its traveling speed when the pendant button is released.	Repair or replace as required.
Housing and Mechanical Components	Visual, Auditory, Vibration, Function	Trolley components including, suspension shafts, track wheels, track wheel axles, clevises, connection yokes, suspension bolts, shafts, gears, bearings, pins, rollers, and bumpers should be free of cracks, distortion, significant wear and corrosion. Evidence of same can be detected visually or via detection of unusual sounds or vibration during operation.	Replace.
Gaskets and Sealing Enclosures	Visual	Gaskets and sealing enclosures must be in good condition and installed properly to preserve the IP rating of the hoist.	Replace.
Side Plates	Visual	Must be free of significant deformation	Replace.
Bolts, Nuts, Snap Rings, and Split Pins	Visual, Check with Proper Tool	Bolts, nuts, snap rings and split pins should not be loose.	Tighten or replace as required.
Track Wheel - Tread	Visual, Measure	Diameter of the inside and outside tread surface should not be less than the discard value shown in Table 5-4 .	Replace.
Track Wheel - Gear	Visual	Teeth should not be cracked, damaged, or excessively worn.	Replace.
Side Rollers - Wear	Visual, Measure	Diameter should not be less than the discard value shown in Table 5-5 .	Replace.
Suspension Shaft	Visual, Measure	Suspension shaft should not be bent. Diameter should not be worn by 10% or more.	Replace.
Motor Brake	Visual, Measure	Brake lining dimension "A" should not be less than discard value listed in Table 5-6 . Refer to Section 6.3 for gaining access to motor brake and inspection procedures. Braking surfaces should be clean, free of grease/oil and should not be glazed.	Replace.
Contactors Contacts	Visual	Contacts should be free of significant pitting or deterioration.	Replace

Table 5-3 Trolley Inspection Methods and Criteria			
Item	Method	Criteria	Action
VFD (Dual Speed only)	Visual, Function	There should be no fault codes (Reference Section 3.5.)	Replace as needed.
Pendant - Switches	Function	Depressing and releasing push buttons should make and break contacts in switch contact block and result in corresponding electrical continuity or open circuit. Push-buttons should be interlocked either mechanically or electrically to prevent simultaneous energization of circuits for opposing motions (e.g. forward and reverse).	Repair or replace as necessary.
Pendant - Housing	Visual	Pendant housing should be free of cracks and mating surfaces of parts should seal without gaps.	Replace.
Pendant - Wiring	Visual	Wire connections to switches in pendant should not be loose or damaged.	Tighten or repair
Pendant And Power Cords	Visual, Electrical Continuity	Surface of cord should be free from nicks, gouges, and abrasions. Each conductor in cord should have 100% electrical continuity even when cord is flexed back-and-forth. Pendant Cord Strain Relief Cable should absorb all of the load associated with forces applied to the pendant.	Replace.
Electrical Plugs, Sockets and Fittings	Visual	Electrical Plugs, Sockets and Fittings should not be cracked or damaged.	Repair or replace as necessary.
Cable Hangers	Visual	Cable Hangers should not be damaged or significantly worn. Movement should be smooth and should not cause the Power Supply Cable to twist or kink.	Repair or replace as necessary.
Pendant - Labels	Visual	Labels denoting functions should be legible.	Replace.
Warning Labels	Visual	Warning Labels should be affixed to the pendant cord (see Section 1.2) and they should be legible.	Replace.
Trolley Capacity Label	Visual	The label that indicates the capacity of the trolley should be legible and securely attached to the trolley.	Replace.
Nameplates	Visual	The nameplates that indicate the trolley model, speed and motor data should be legible and securely attached to the trolley.	Replace

Table 5-4 Track Wheel Wear Dimensions

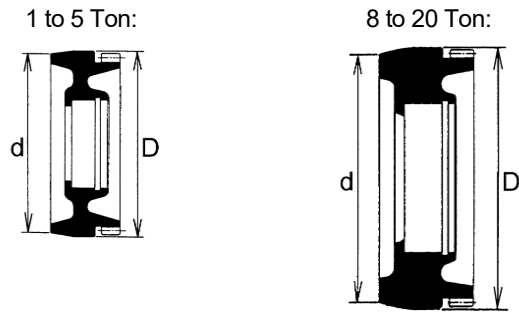

Note: Track wheels are for flat and tapered flanges.

Capacity (Ton)	"d" Dimension inch (mm)		"D" Dimension inch (mm)	
	Standard	Discard	Standard	Discard
1	3.60 (91.5)	3.44 (87.5)	3.74 (95)	3.58 (91)
2	4.17 (106)	3.98 (101)	4.33 (110)	4.13 (105)
3	4.76 (121)	4.49 (114)	4.92 (125)	4.65 (118)
5	5.31 (135)	5.00 (127)	5.51 (140)	5.20 (132)
8 to 20	6.34 (166)	6.14 (156)	6.89 (175)	6.50 (165)

Table 5-5 Side Roller Wear Dimensions

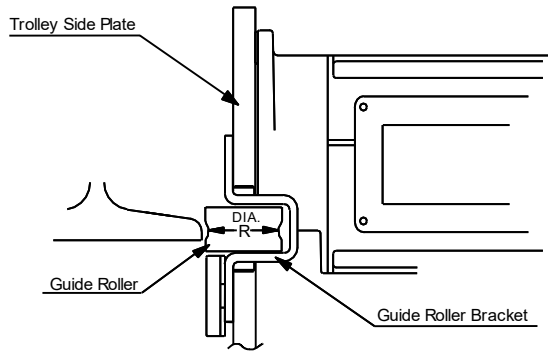

Capacity (Ton)	"R" Dimension inch (mm)	
	Standard	Discard
1	1.50 (38)	1.46 (37)
2 and 3	1.69 (43)	1.65 (42)
5 to 20	2.17 (55)	2.13 (54)

Table 5-6 Motor Brake Wear Dimensions

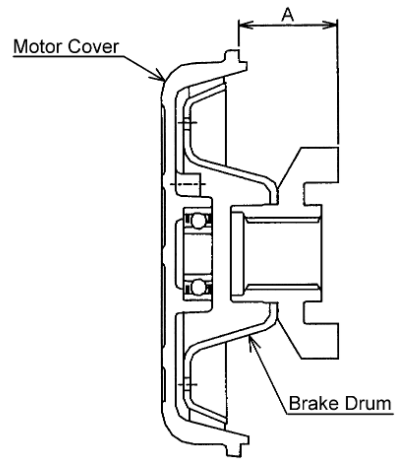

Capacity (Ton)	"A" Dimension - inch (mm)			
	Single Speed		Dual Speed	
	Standard	Discard	Standard	Discard
1 and 2	1.28 (32.5)	1.22 (31.0)	1.45 (36.8)	1.43 (36.3)
3 to 20	1.28 (32.5)	1.22 (31.0)	1.45 (36.8)	1.41 (35.8)

6.0 Maintenance & Handling

















6.1 Count/Hour Meter (Dual Speed Only)

6.1.1 Dual Speed

- On dual speed trolleys, the VFD has a Count/Hour function built into the parameters. Refer to Table 6-1 for parameter identification. Refer to Table 6-2 for Count/Hour access procedure.

Parameter	Name	Description
U7-01	Number of Starts (Higher Order)	The number of starts in the down direction x 1,000. Up to 10,000 units are displayed. Display of "1" = 1,000 starts. Display of "10,000" = 10,000,000 starts
U7-02	Number of Starts (Lower Order)	The number of starts in the down direction under 1,000 starts (1 to 999). One start will register a "1" in the display. When 1,000 starts are reached, the value of U7-01 is incremented by 1 and the value of U7-02 is reset to 0.
U7-03	Hours of Operation	The number of hours of operation in both the up and down directions. One hour will register a "1" in the display. Up to 65535 hours are displayed.

- Example using Table 6-1:
 - U7-01 displays "81", U7-02 displays "567", U7-03 displays "122"
 - Number of Starts (down) = 81,567
 - Number of Operated Hours = 122

Operational Step	VFD Display
1. Energize the hoist.	
2. Press  until the "Monitor" screen is displayed (blinking).	
3. Press  to display the parameter setting screen and then press  to move from "01" to "U1".	
4. Press  or  until the display reads "U7" (left value blinking).	
5. Press  and  or  to select the specific "Monitor" parameter (right value blinking). (Example: U7-03 –Hours of Operation)	
6. Press  to display the current parameter value. (Example: 75 Hours)	
7. Press  until the display returns to the initial screen. (As in Step 1.)	

- 6.1.2 Gear Lubricant – The Dual Speed Trolley C/H Meter can be used in conjunction with the average operation of the trolley to estimate when the gear lubricant should be changed. Refer to Section 6.2.3.
- 6.1.3 You are encouraged to use the Dual Speed Trolley Count/Hour Meter in conjunction with your experience with the trolley's application and usage to develop a history upon which to gage and fine tune your maintenance program for the trolley.

6.2 Lubrication

- 6.2.1 Lubricate the following trolley components with NLGI (National Lubricating Grease Institute) #2 or equivalent grease.
- 6.2.2 Track Wheel Gear – Clean and re-grease the Track Wheel gears and motor output pinion every three months (more frequently for heavier usage or severe conditions). Do not use an excessive amount of grease and avoid getting any grease on the running surfaces of the Track Wheels or the beam.
- 6.2.3 Gear Box – The reduction gearing in the motor should be cleaned and lubricated at least once per year for normal usage. Clean and lubricate the reduction gear assembly more frequently for heavier usage or severe conditions. Gain access to the gears by removing the four bolts that mount the motor assembly to the trolley Side Plate. Make sure to properly orient and reuse the neoprene gasket between the motor and Side Plate.
- 6.2.4 Suspension Pins, Bolts and Shafts – Grease at least twice per year for normal usage (more frequently for heavier usage or severe conditions).

6.3 Brake

- 6.3.1 The trolley motor brake is NOT adjustable.
- 6.3.2 Motor Brake Removal – Remove the four Bolts that attach the Motor Cover to the Motor Frame. Carefully remove the Motor Cover, brake components, and Stator.
- 6.3.3 Brake Lining Inspection – The brake lining is designed for a long life and should provide years of trouble-free service. If the brake lining is being inspected due to excessive trolley drift during operation (see Section 5.7), disassemble the motor brake and inspect all motor brake parts. Braking surfaces should be clean, free of grease/oil and should not be glazed. Replace the Brake Drum and/or Motor Cover if necessary. For normal inspections, the Brake Lining and Motor Cover wear should be measured as follows.
 - 1) Refer to Table 5-6.
 - 2) Measure the distance "A" using calipers and a straight edge. Make sure the Brake Drum is square against the Motor Cover. Place the straight edge across the edge of the Brake Drum and measure from the straight edge to the mounting face of the Motor Cover.
 - 3) Compare the measurement with the values listed in Table 5-6. Replace the Brake Drum and/or Motor Cover if the "A" measurement is smaller than the discard limit.
- 6.3.4 Motor Brake Installation - After the brake is inspected, carefully place the Stator and brake components into the Motor Frame. Be sure to reseal the Motor Cover to Motor Frame surface using a small bead of liquid (hi-temperature) sealant. Install the Motor Cover attachment bolts.

6.4 Storage

- 6.4.1 The storage location should be clean and dry.
- 6.4.2 Care should be take to not damage any of the electrical power cords or fittings.

6.5 Outdoor Installation

- 6.5.1 The hoist/trolley should be covered when not in use.
- 6.5.2 The hoist/trolley **MUST BE** inspected and maintained according to the 'Severe Service' Inspection Classification. **Refer to Section 5.0.**
- 6.5.3 When reinstalling the control cover, the gasket **MUST BE** in good condition and installed properly to preserve the IP55 rating of the hoist.
- 6.5.4 When using a steel chain container, remove the plug to allow for the drainage of pooling water. When using a plastic chain container, drill a 1/8" hole in the plastic to allow for drainage. Canvas chain containers are not recommended for outdoor use.
- 6.5.5 Possibility of corrosion on components of the hoist/trolley increases for installations where salt air and high humidity are present. For installations where temperature variations introduce condensation/corrosion into the hoist, more frequent lubrication may be required.
- 6.5.6 NEMA 4 Pendants are recommended for outdoor use.
- 6.5.7 Refer to **Section 2.1.3** for allowable environmental conditions.

6.6 Operational Environment

- 6.6.1 Non-conforming environment

A non-conforming environment is defined as one with any or all of the following.

 - Explosive gases or vapor.
 - Organic solvents or volatile powder
 - Excessive amounts of powder and dust of general substances
 - Excessive amount of acids or salts.

7.0 Troubleshooting

WARNING

HAZARDOUS VOLTAGES ARE PRESENT IN THE TROLLEY AND IN CONNECTIONS BETWEEN COMPONENTS.

Before performing ANY maintenance on the equipment, de-energize the supply of electricity to the equipment, and lock and tag the supply device in the de-energized position. Refer to ANSI Z244.1, "Personnel Protection – Lockout/Tagout of Energy Sources."

To avoid a shock hazard, **DO NOT** perform **ANY** mechanical or electrical maintenance on the dual speed (or VFD control) trolley or hoist within 5 minutes of de-energizing (disconnecting) the trolley or hoist. This time allows the internal VFD capacitor to safely discharge.

Only trained and competent personnel should inspect and repair this equipment.

NOTICE

Do Not perform "withstand voltage" test or "insulation resistance" measurement (megger) with the VFD connected.

Do Not remove power to the hoist or trolley during operation.

Do Not connect power to the output of the VFD.

When handling VFD provide ESD protection.

Table 7-1 Troubleshooting Guide

Symptom	Cause	Remedy
Trolley will not operate	Loss of power	Check circuit breakers, switches, fuses and connections on power lines/cable.
	Wrong voltage or frequency	Check voltage and frequency of power supply against the rating on the nameplate of the motor.
	Motor overheated and thermal overload protector has tripped	See Troubleshooting Problem "Motor or brake overheating".
	Improper, loose, or broken wire in trolley electrical system	Shut off power supply, check wiring connections in the trolley switch box, on hoist control panel and inside push-button pendant.
	Faulty magnetic contactor	Check coil for open or short circuit. Check all connections in the control circuit. Check for open contactors. Replace as needed.
	Faulty VFD (dual speed only)	Check fault codes (Reference Section 3.5). Reset VFD by pressing the Emergency Stop button on the pendant. Replace as needed.
	Emergency Stop Depressed on Push Button Pendant Control	"Hbb" will appear on the dual speed unit's VFD display when the Emergency Stop Button is depressed. Turn the Emergency Stop Button clockwise to unlock the controls and allow hoist operation.

Table 7-1 Troubleshooting Guide		
Symptom	Cause	Remedy
	Motor burned out	Replace motor frame/stator, shaft/rotor, and any other damaged parts.

Table 7-1 Troubleshooting Guide		
Symptom	Cause	Remedy
Trolley drifts excessively when stopping	Motor brake not holding	Clean and inspect brake lining. Replace if necessary
	VFD Deceleration parameter adjusted incorrectly (Dual Speed only)	Readjust VFD Deceleration parameter (Reference Section 3.5.11).
Motor or brake overheating	Excessive duty cycle	Reduce frequency of trolley movement.
	Extreme external heating	Above an ambient temperature of 140°F, the frequency of trolley operation must be reduced to avoid overheating of the motor. Special provisions should be made to ventilate the trolley or otherwise shield it from the heat.
Trolley operates intermittently	Collectors making poor contact	Check movement of spring loaded arm, weak spring, connections, and shoe. Replace as needed.
	Contactors contacts arcing	Check for burned contacts. Replace as needed.
	Faulty VFD (dual speed only)	Check fault codes (Reference Section 3.5). Replace as needed.
	Loose connection in circuit	Check all wires and terminals for bad connections. Replace as needed.
	Broken conductor in Pendant Cord	Check for intermittent continuity in each conductor the Pendant Cord. Replace entire Pendant Cord if continuity is not constant.

8.0 Warranty

All products sold by Harrington Hoists, Inc. are warranted to be free from defects in material and workmanship from date of shipment by Harrington for the following periods:

- 1 year – Electric and Air Powered Hoists (excluding (N)ER2 Enhanced Features Models), Powered Trolleys, Powered Tiger Track Jibs and Gantries, Crane Components, Below the Hook Devices, Spare / Replacement Parts**
- 2 years – Manual Hoists & Trolleys, Beam Clamps**
- 3 years – (N)ER2 Enhanced Features Model Hoists**
- 5 years – Manual Tiger Track Jibs and Gantries, TNER Pull - Rotor Motor Brake**
- 10 years – (N)ER2 “The Guardian” Smart Brake**

The product must be used in accordance with manufacturer’s recommendations and must not have been subject to abuse, lack of maintenance, misuse, negligence, or unauthorized repairs or alterations.

Should any defect in material or workmanship occur during the above time period in any product, as determined by Harrington Hoist’s inspection of the product, Harrington Hoists, Inc. agrees, at its discretion, either to replace (not including installation) or repair the part or product free of charge and deliver said item F.O.B. Harrington Hoists, Inc. place of business to customer.

Customer must obtain a Return Goods Authorization as directed by Harrington or Harrington’s published repair center prior to shipping product for warranty evaluation. An explanation of the complaint must accompany the product. Product must be returned freight prepaid. Upon repair, the product will be covered for the remainder of the original warranty period. Replacement parts installed after the original warranty period will only be eligible for replacement (not including installation) for a period of one year from the installation date. If it is determined there is no defect, or that the defect resulted from causes not within the scope of Harrington’s warranty, the customer will be responsible for the costs of returning the product.

Harrington Hoists, Inc. disclaims any and all other warranties of any kind expressed or implied as to the product’s merchantability or fitness for a particular application. Harrington will not be liable for death, injuries to persons or property or for incidental, contingent, special or consequential damages, loss or expense arising in connection with the use or inability whatever, regardless of whether damage, loss or expense results from any act or failure to act by Harrington, whether negligent or willful, or from any other reason.

This Page Intentionally Left Blank



Harrington Hoists, Inc.
401 West End Avenue
Manheim, PA 17545

www.harringtonhoists.com

Toll Free: 800-233-3010
Phone: 717-665-2000
Fax: 717-665-2861

MR20M-ENG