Owner's Manual

MANUAL TROLLEY TF2/TS2 SERIES

1/2 Ton through 20 Ton Capacity

Code, Lot and Serial Number

⚠ WARNING

This equipment should not be installed, operated or maintained by any person who has not read and understood all the contents of this manual. Failure to read and comply with the contents of this manual can result in serious bodily injury or death, and/or property damage.

HARRINGTON
A **KITO** GROUP COMPANY

Table of Contents

Section	Page Number
1.0 Important Information and Warnings.....	4
1.1 Terms and Summary	
1.2 Warning Tags and Labels	
2.0 Technical Information	8
2.1 Specifications	
2.2 Dimensions	
2.3 Optional Equipment	
3.0 Pre-operational Procedures.....	19
3.1 Manual Hoist Adjustment for Trolley	
3.2 Electric Hoist Adjustment for Trolley	
3.3 Air Power Hoist Adjustment for Trolley	
3.4 Trolley Assembly	
3.5 Mounting Location	
3.6 Installation of Trolley onto Beam	
3.7 Electrical/Air Connections	
3.8 Pre-operational Checks and Trial Operation	
4.0 Operation.....	51
4.1 Introduction	
4.2 Shall's and Shall Not's for Operation	
4.3 Trolley Controls	
5.0 Inspection.....	54
5.1 General	
5.2 Inspection Classification	
5.3 Frequent Inspection	

Section	Page Number	
5.4	Periodic Inspection	
5.5	Occasionally Used Trolleys	
5.6	Inspection Records	
5.7	Inspection Methods and Criteria	
6.0	Maintenance & Handling.....	60
6.1	Lubrication	
6.2	Storage	
6.3	Outdoor Installation	
7.0	Warranty.....	61
8.0	Parts List.....	63
8.1	TF2 Push Trolley Parts – 1/8 to 5 Ton	
8.2	TF2 Geared Trolley Parts – 1/8 to 5 Ton	
8.3	TS2 Push Trolley Parts – 1/8 to 5 Ton	
8.4	TS2 Geared Trolley Parts – 1/8 to 5 Ton	
8.5	TF/TS Push/Geared Trolley Parts for CB Hoist – 8 to 10 Ton	
8.6	TF/TS Push/Geared Trolley Parts for ER2 Hoist – 8 to 10 Ton	
8.7	TF/TS Geared Trolley Parts for CB Hoist – 15 to 20 Ton	
8.8	TF/TS Geared Trolley Parts for ER2 Hoist – 15 to 20 Ton	

1.0 Important Information and Warnings

1.1 Terms and Summary

This manual provides important information for personnel involved with the installation, operation and maintenance of this product. Although you may be familiar with this or similar equipment, it is strongly recommended that you read this manual before installing, operating or maintaining the product.

Danger, Warning, Caution and Notice - Throughout this manual there are steps and procedures that can present hazardous situations. The following signal words are used to identify the degree or level of hazard seriousness.

▲ DANGER Danger indicates an imminently hazardous situation which, if not avoided, *will* result in *death or serious injury*, and property damage.

▲ WARNING Warning indicates an imminently hazardous situation which, if not avoided, *could* result in *death or serious injury*, and property damage.

▲ CAUTION Caution indicates a potentially hazardous situation which, if not avoided, *may* result *minor or moderate injury* or property damage.

NOTICE Notice is used to notify people of installation, operation, or maintenance information which is important but not directly hazard-related.

▲ CAUTION

These general instructions deal with the normal installation, operation, and maintenance situations encountered with the equipment described herein. The instructions should not be interpreted to anticipate every possible contingency or to anticipate the final system, crane, or configuration that uses this equipment. For systems using the equipment covered by this manual, the supplier and owner of the system are responsible for the system's compliance with all applicable industry standards, and with all applicable federal, state and local regulations/codes.

This manual includes instructions and parts information for a variety of trolley and hoist types. Therefore, all instructions and parts information may not apply to any one type or size of specific trolley or hoist. Disregard those portions of the instructions that do not apply.

Record your trolley's Code, Lot and Serial Number on the front cover of this manual for identification and future reference to avoid referring to the wrong manual for information or instructions on installation, operation, inspection, maintenance, or parts.

Use only Harrington authorized replacement parts in the service and maintenance of this trolley.

WARNING

Equipment described herein is not designed for and **MUST NOT** be used for lifting, supporting, or transporting people, or for lifting or supporting loads over people.

Equipment described herein should not be used in conjunction with other equipment unless necessary and/or required safety devices applicable to the system, crane, or application are installed by the system designer, system manufacturer, crane manufacturer, installer, or user.

Modifications to upgrade, rerate, or otherwise alter this equipment shall be authorized only by the original equipment manufacturer.

Equipment described herein may be used in the design and manufacture of cranes or monorails. Additional equipment or devices may be required for the crane and monorail to comply with applicable crane design and safety standards. The crane designer, crane manufacturer, or user is responsible to furnish these additional items for compliance. Refer to ANSI/ASME B30.17, "Safety Standard for Top-Running Single Girder Cranes"; ANSI/ASME B30.2 "Safety Standard for Top-Running Double-Girder Cranes"; and ANSI/ASME B30.11 "Safety Standard for Underhung Cranes and Monorails".

If a below-the-hook lifting device or sling is used with a hoist, refer to ANSI/ASME B30.9, "Safety Standard for Slings" or ANSI/ASME B30.20, "Safety Standard for Below-the-Hook Lifting Devices".

Hoists, trolleys and cranes, used to handle hot molten material may require additional equipment or devices. Refer to ANSI Z241.2, "Safety Requirements for Melting and Pouring of Metals in the Metalcasting Industry".

Electrical equipment described herein is designed and built in compliance with Harrington's interpretation of ANSI/NFPA 70, "National Electrical Code". The system designer, system manufacturer, crane designer, crane manufacturer, installer, or user is responsible to assure that the installation and associated wiring of these electrical components is in compliance with ANSI/NFPA 70, and all applicable Federal, State and Local Codes.

Failure to read and comply with any one of the limitations noted herein can result in serious bodily injury or death, and/or property damage.

DANGER

HAZARDOUS VOLTAGES ARE PRESENT IN THE HOIST CONTROL BOX, OTHER ELECTRICAL COMPONENTS, AND CONNECTIONS BETWEEN THESE COMPONENTS.

Before performing ANY mechanical or electrical maintenance on the equipment, de-energize (disconnect) the main switch supplying power to the equipment; and lock and tag the main switch in the de-energized position. Refer to ANSI Z244.1, "Personnel Protection – Lockout/Tagout of Energy Sources".

Only trained and competent personnel should inspect and repair this equipment.

NOTICE

It is the responsibility of the owner/user to install, inspect, test, maintain, and operate a trolley or hoist in accordance with ANSI/ASME B30.16, "Safety Standard for Overhead Hoists", OSHA Regulations and ANSI/NFPA 70, "National Electric Code". If the trolley is installed as part of a total lifting system, such as an overhead crane or monorail, it is also the responsibility of the owner/user to comply with the applicable ANSI/ASME B30 volume that addresses that type of equipment.

It is the responsibility of the owner/user to have all personnel that will install, inspect, test, maintain, and operate a hoist read the contents of this manual and applicable portions of ANSI/ASME B30.16, "Safety Standard for Overhead Hoists", OSHA Regulations and ANSI/NFPA 70, "National Electric Code". If the trolley is installed as part of a total lifting system, such as an overhead crane, the applicable ANSI/ASME B30 volume that addresses that type of equipment must also be read by all personnel.

If the trolley owner/user requires additional information, or if any information in the manual is not clear, contact Harrington or the distributor of the trolley. Do not install, inspect, test, maintain, or operate this trolley unless this information is fully understood.

A regular schedule of inspection of the trolley in accordance with the requirements of ANSI/ASME B30.16 should be established and records maintained.

1.2 Warning Tag and Labels

The warning tag illustrated below in Figure 1-1 is supplied with each trolley shipped from the factory. If the tag is not attached to the pendant cord for your hoist/trolley, order a tag from your dealer and install it. Read and obey all warnings attached to this trolley. Tag is not shown actual size.

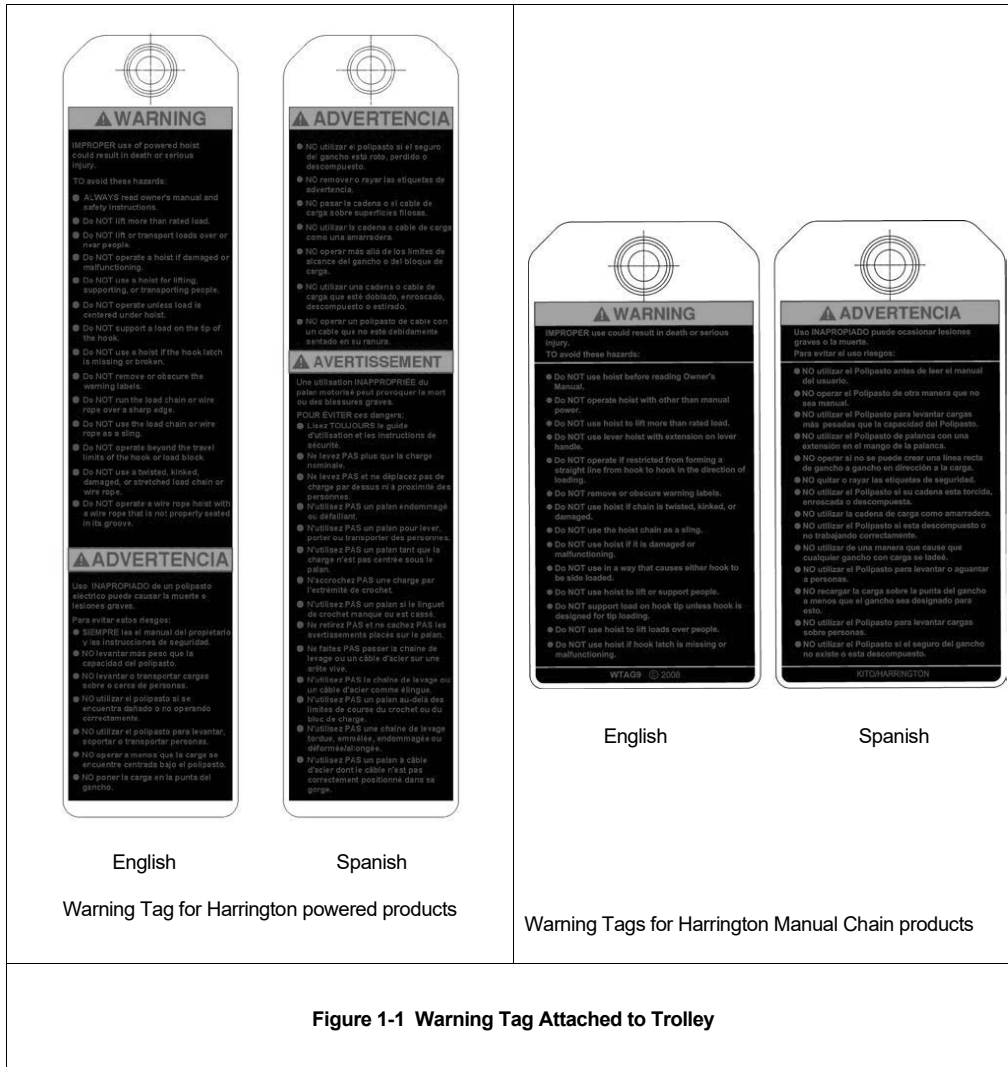
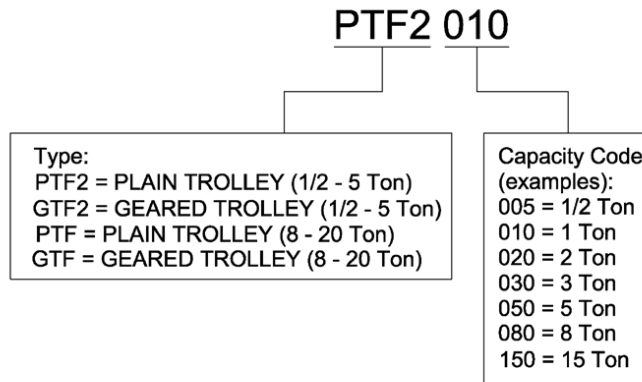

Figure 1-1 Warning Tag Attached to Trolley

2.0 Technical Information

2.1 Specifications

2.1.1 Product Code for TF2 Trolley:



2.1.2 Product Code for TS2 Trolley:

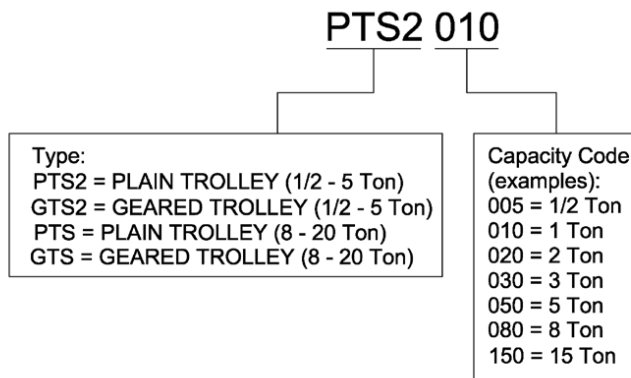

2.1.3 Operating Conditions and Environment

Temperature Range: -4° to +104°F (-20° to +40°C)

Humidity: 85% or less

2.1.4 PTF2 Specifications

Table 2-1 PTF2 Trolley Specifications					
Cap. (Tons)	Product Code	Min. Radius for Curve (in)	Flange Width Adjustability B (in)		Approx. Net Weight (lbs)
			Standard	Option	
1/2	PTF2005	13.8	2.28 to 4.00	4.01 to 8.00 or 8.01 to 12.00	9
1	PTF2010	17.7	2.28 to 5.00	5.01 to 8.00 or 8.01 to 12.00	15
1 1/2-2	PTF2020	21.7	3.23 to 6.02	6.03 to 12.00	29
2 1/2-3	PTF2030	25.6			46
5	PTF2050	78.7	4.92 to 7.02	7.03 to 12.00	95
8	PTF080	118.1	5.50 to 8.66	8.67 to 12.00	212
10	PTF100				

2.1.5 PTS2 Specifications

Table 2-2 PTS2 Trolley Specifications					
Cap. (Tons)	Product Code	Min. Radius for Curve (in)	Flange Width Adjustability B (in)		Approx. Net Weight (lbs)
			Standard	Option	
1/2	PTS2005	43.3	2.28 to 4.00	4.01 to 8.00 or 8.01 to 12.00	10
1	PTS2010	51.2	2.28 to 5.00	5.01 to 8.00 or 8.01 to 12.00	18
1 1/2-2	PTS2020	59.1	3.23 to 6.02	6.03 to 12.00	31
2 1/2-3	PTS2030	66.9			51
5	PTS2050	90.6	3.94 to 7.02	7.03 to 12.00	110
8	PTS080	118.1	5.50 to 8.66	8.67 to 12.00	220
10	PTS100				

2.1.6 GTF2 Specifications

Table 2-3 GTF2 Trolley Specifications						
Cap. (Tons)	Product Code	Min. Radius for Curve (in)	Flange Width Adjustability B (in)		Approx. Net Weight (lbs)	
			Standard	Option	ER2	CB
1	GTF2010	17.7	2.28 to 5.00	5.01 to 8.00 or 8.01 to 12.00	24	
1 1/2-2	GTF2020	21.7	3.23 to 6.02	6.03 to 12.00	38	
2 1/2-3	GTF2030	25.6			55	
5	GTF2050	78.7	4.92 to 7.02	7.03 to 12.00	104	
8	GTF080	118.1	5.50 to 8.66	8.67 to 12.00	248	218
10	GTF100				490	534
15	GTF150					
20	GTF200	∞				

2.1.7 GTS2 Specifications

Table 2-4 GTS2 Trolley Specifications						
Cap. (Tons)	Product Code	Min. Radius for Curve (in)	Flange Width Adjustability B (in)		Approx. Net Weight (lbs)	
			Standard	Option	ER2	CB
1	GTS2010	51.2	2.28 to 5.00	5.01 to 8.00 or 8.01 to 12.00	27	
1 1/2-2	GTS2020	59.1	3.23 to 6.02	6.03 to 12.00	42	
2 1/2-3	GTS2030	66.9			60	
5	GTS2050	90.6	3.94 to 7.02	7.03 to 12.00	124	
8	GTS080	118.1	5.50 to 8.66	8.67 to 12.00	257	227
10	GTS100				510	553
15	GTS150					
20	GTS200	∞				

2.2 Dimensions

2.2.1 PTF2 Dimensions

Table 2-5 PTF2 Trolley Dimensions															
<p>PTF2005 to PTF2030</p>								<p>PTF2050 to PTF100</p>							
Cap. (Tons)	Product Code	a max (in)	a' (in)	b (in)	e (ft)	h (in)	i (in)	j (in)	k (in)	m (in)	n (in)	r (in)	s (in)	t (in)	v (in)
1/2	PTF2005	6.8	8.0	7.2	1.8	3.2	2.36	0.80	3.0	2.7	3.3	1.5	B-1.8	0.87	3.7
1	PTF2010	8.5	9.8	9.3	2.2	4.2	2.80	1.1	3.7	3.1	4.4	2.0	B-1.9	0.98	4.2
1 1/2-2	PTF2020	10.4	11.8	11.0	2.7	5.0	3.35	1.4	4.4	3.8	5.2	2.4	B-2.3	1.26	5.1
2 1/2-3	PTF2030	11.0	12.6	12.8	3.1	5.8	3.94		5.3	4.3	6.0	2.7	B-2.3	1.42	6.7
5	PTF2050	10.7	11.7	13.7	2.1	6.7	4.65		5.7	3.6	7.0	3.5	B-3.0	1.73	3.7
8	PTF080	14.4	19.2	18.9	4.1	7.3	6.10	-	6.7	5.9	7.7	6.0	B-3.6	2.76	4.7
10	PTF100														

2.2.2 PTS2 Dimensions

Table 2-6 PTS2 Trolley Dimensions

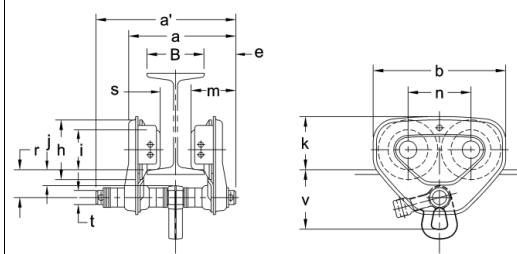

PTS2005 to PTS2030

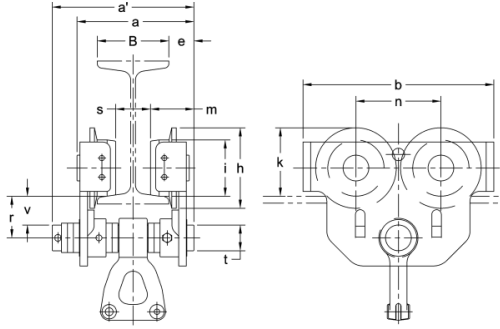

PTS2050 to PTS100

Cap. (Tons)	Product Code	a max (in)	a' (in)	b (in)	e (ft)	h (in)	i (in)	j (in)	k (in)	m (in)	n (in)	r (in)	s (in)	t (in)	v (in)
1/2	PTS2005	6.8	8.0	7.2	1.8	3.2	2.36	0.7	3.0	2.7	3.3	1.5	B-1.8	0.87	3.7
1	PTS2010	8.5	9.8	9.3	2.2	4.2	2.80	1.1	3.7	3.1	4.4	2.0	B-1.9	0.98	4.2
1 1/2-2	PTS2020	10.4	11.8	11.0	2.7	5.0	3.35	1.3	4.4	3.8	5.2	2.4	B-2.3	1.26	5.1
2 1/2-3	PTS2030	11.0	12.6	12.8	3.1	5.8	3.94	1.4	5.3	4.3	6.0	2.7	B-2.3	1.42	6.7
5	PTS2050	10.7	11.7	15.7	2.1	6.7	4.65	1.8	5.7	3.2	7.0	3.5	B-3.0	2.13	3.7
8	PTS080	14.4	19.2	19.4	4.1	7.3	6.10	-	6.7	5.9	7.7	6.0	B-3.6	2.76	4.7
10	PTS100														

2.2.3 GTF2 Dimensions

Table 2-7 GTF2 Trolley Dimensions

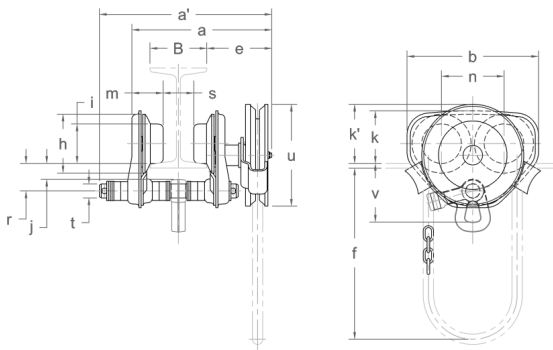

GTF2010 to GTF2030

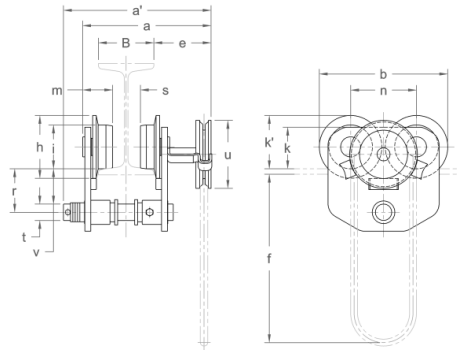

GTF2050 to GTF2100

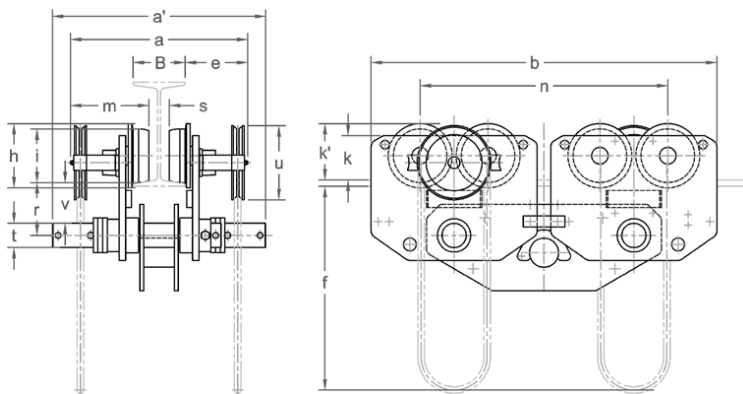

GTF2150 to GTF2200

Cap. (Tons)	Product Code	a max* (in)		a' max (in)		b (in)	e (in)		f (ft.)	h (in)	i (in)	j (in)	k (in)	k' (in)	m (in)		n (in)	r (in)	s (in)	t (in)	u (in)	v (in)		
		ER2	CB	ER2	CB		ER2	CB							ER2	CB								
		1/2-1	GTF2010	10.8	13.6		9.3	6.0																
1 1/2-2	GTF2020	13.7	15.2	11.0	6.1					5.0	3.35	1.3	4.4	4.3	2.8	5.2	2.4	B-1.9	1.26			5.1		
2 1/2-3	GTF2030	14.1	15.7	12.8	6.2					5.8	3.94	1.4	5.3	4.5	3.1	6.0	2.7	B-2.3	1.42			6.7		
5	GTF2050	14.8	15.8	13.7	6.1					6.7	4.65	-	5.7	5.2	3.2	7.0	3.5		1.73			3.7		
8	GTF080	26.4	17.4	31.3	22.2	18.9									3.4	7.7	6.0							
10	GTF100						16.2	7.2	12	7.3	6.10	-	5.4	6.7										
15	GTF150	41.0	23.0	24.3	24.3	39.4									18.0	8.9	28.2	8.0	B-3.6	2.76	8.4	4.6		
20	GTF200																							

*This dimension is variable on 15/20 Ton model, therefore it is recorded at its maximum value for standard range.

2.2.4 GTS2 Dimensions

Table 2-8 GTS2 Trolley Dimensions

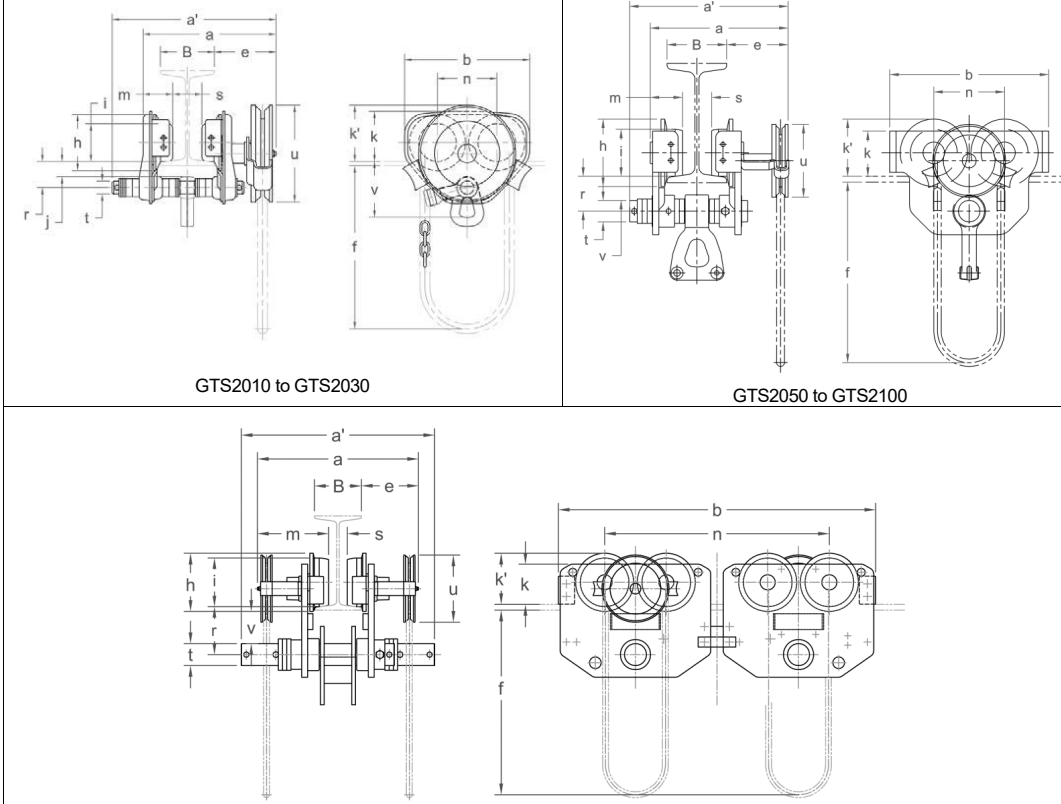

GTS2010 to GTS2030

GTS2050 to GTS2100

GTS2150 to GTS2200

Cap. (Tons)	Product Code	a max* (in)		a' max (in)		b (in)	e (in)		f (ft.)	h (in)	i (in)	j (in)	k (in)	k' (in)	m (in)		n (in)	r (in)	s (in)	t (in)	u (in)	v (in)
		ER2	CB	ER2	CB		ER2	CB							ER2	CB						
1/2-1	GTS2010	10.8		13.6		9.3	6.0		10.5	4.2	2.80	1.1	3.7	4.2	2.2	4.4	2.0	B-1.8	0.98	7.2	4.2	
1 1/2-2	GTS2020	13.7		15.2		11.0	6.1			5.0	3.35	1.3	4.4	4.3	2.8	5.2	2.4	B-1.9	1.26		5.1	
2 1/2-3	GTS2030	14.1		15.7		12.8	6.2	11.0		5.8	3.94	1.4	5.3	4.5	3.1	6.0	2.7	B-2.3	1.42		6.7	
5	GTS2050	14.8		15.8		15.8	6.1	11.4	6.7	4.65	1.8	5.7	5.2	3.2	7.0	3.5		2.13	3.7			
8	GTS080	26.4	17.4	31.3	22.2	19.4									3.4	7.7	6.0					
10	GTS100						16.2	7.2	12	7.3	6.10	-	5.4	6.7				B-3.6	2.76	8.4	4.6	
15	GTS150	41.0	23.0	24.3	24.3	39.8									18.0	8.9	28.2	8.0				
20	GTS200																					

*This dimension is variable on 15/20 Ton model, therefore it is recorded at its maximum value for standard range.

2.3 Optional Equipment

2.3.1 Suspender C

Table 2-9 Suspender C Dimensions						
C (1/2 to 2 1/2 Ton)			C (3 to 5 Ton)			
Capacities (Tons)	a (in)	b (in)	c (in)	d (in)	e (in)	f (in)
1/2	1.0	1.3	0.6	0.87	2.1	2.6
1	1.1	1.5	0.7	0.99	2.2	2.7
2	1.3	1.6	0.9	1.27	2.7	3.2
2 1/2	1.4	1.7	1.0	1.43	3.0	3.6
3	1.6	1.9	1.2	1.43	4.0	4.5
5	2.4	2.8	1.4	2.13	5.5	6.1

2.3.2 Suspender H

Table 2-10 Suspender H Dimensions					
H					
Capacities (Tons)	a (in)	b (in)	c (in)	d (in)	e (in)
1/4-1/2	1.0	1.3	0.4	0.91	2.3
1	1.1	1.5	0.5	1.02	2.6
1 1/2-2	1.4	1.8	0.7	1.30	3.3
2 1/2-3	1.7	2.1	0.9	1.46	3.9

2.3.3 Suspender E & G

Table 2-11 Suspender E & G Dimensions									
Suspender	Capacities (Ton)	d1	D	d2	B	P	L	T	W
E	1/8 to 1/2	0.874	1.46	0.480	1.30	2.36	3.60	1.06	0.94
	1	0.992	1.65	0.480	1.30	2.72	4.06	1.06	0.94
	1 1/2 to 2	1.268	2.13	0.795	1.73	2.99	4.84	1.54	1.42
	2 1/2 to 3	1.425	2.48	0.795	1.73	3.35	5.47	1.54	1.77
G	5	2.13	3.23	1.11	1.93	3.35	6.22	2.32	2.52

2.3.4 Suspension Bar (used for EQ/SEQ hoists)

Table 2-12 Suspension Bar Dimension for (S)EQ Hoists							
Units = inch							
Capacity Code	a	b	c	d	e	f	g
EQ001SD EQ003SD EQ005SD	5.5	2.7	0.6	0.7	0.6	1.3	0.5
EQ010SD	6.0	2.8	0.6	0.6	0.9	1.3	0.5

2.3.5 TCR Suspender (used for Air Hoist)

Table 2-13 TCR Suspender Dimensions

Model Hoist	Suspender P/N	Cap (Ton)	a (in)	b (in)	c (in)	d (in)	e (in)	f (in)	g (in)
TCR250 TCR/L500	6040204	¼ TO ½	2.00	5.33	3.78	.875	1.10	R 1.00	0.512
TCR1000	6040201	1	2.00	5.33	3.78	1.230	1.10	R 1.00	0.512
TCR1000-2	60403	1	3.00	5.38	3.78	1.230	1.10	--	0.512
TCR2000-2	6040403	2	3.25	5.56	3.54	1.703	1.10	--	0.512
TCR3000	TF26K531030S	3	2.44	4.80	2.83	1.42	1.77	R 1.22	0.795
TCR6000-2	60405	6	4.48	6.91	3.75	2.761	1.75	R 2.25	0.787
TCR10000-2	60926	10	5.00	9.41	5.64	2.764	3.22	R2.50	1.379

TCR250, TCR500, TCR1000, TCR3000

TCR1000-2, TCR2000-2

TCR6000-2

TCR10000-2

2.3.6 TCS, TCK, and TCL Suspender (used for Air Hoist)

Table 2-14 TCS/K/L Suspender Dimensions

<p>TCS/L250, TCS/L500</p>		<p>TCS/L1000</p>						
<p>TCK/L3000</p>		<p>TCK/L6000</p>						
Model Hoist	Suspender P/N	Cap (Ton)	a (in)	b (in)	c (in)	d (in)	e (in)	f (in)
TCS/L250 TCS/L500	60396	¼ to ½	2.06	2.50	1.42	0.86	0.32	1.06
TCS/L1000	70271	1	3.57	2.63	1.37	1.00	0.31	0.53
TCK/L3000	TCK30DKJ110	3	3.78	4.72	2.57	1.46	0.63	1.77
TCK/L6000	TCK60DKJ110	6	6.69	8.19	4.72	2.80	0.59	1.77

3.0 Pre-operational Procedures

3.1 Manual Hoist Adjustment for Trolley

- 3.1.1 For ½ - 5 Ton capacities, Harrington's Model CB Series chain hoist can be Hook mounted to the TF2/TS2 Trolley using suspender "C" as shown in **Figure 3-1** or Lug mounted to suspender "C" as shown in **Figure 3-2**

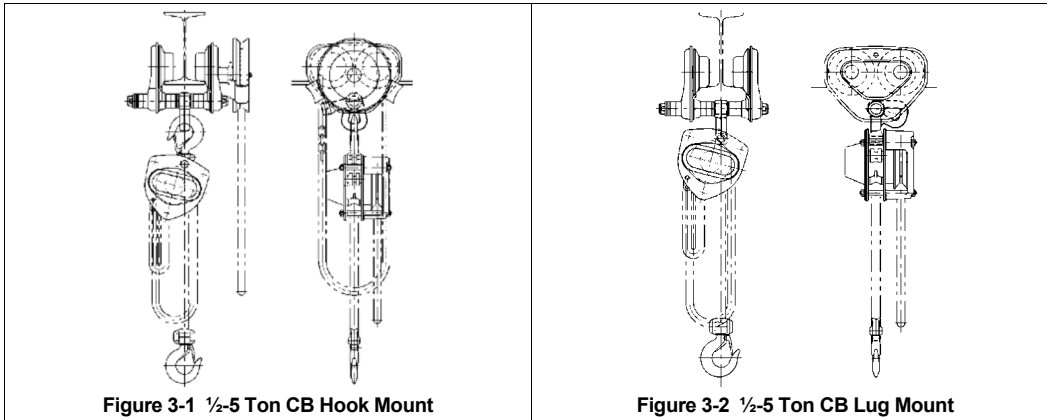

- 3.1.2 Direct coupling lug mounted method for CB Series.

- 1) For ½ to 2 ½ Ton capacity Refer to **Figure 3-3**.
- 2) Remove the wheel cover nuts and lock washers, then remove wheel cover.
- 3) Straighten and remove the spit pin in the top shaft pin and remove the top shaft pin, remove the top hook.
- 4) Mount suspender "C" (small) in place of the top hook, insert the top shaft pin and re-insert the split pin.
- 5) Replace the wheel cover.
- 6) Attach Hoist to Trolley.

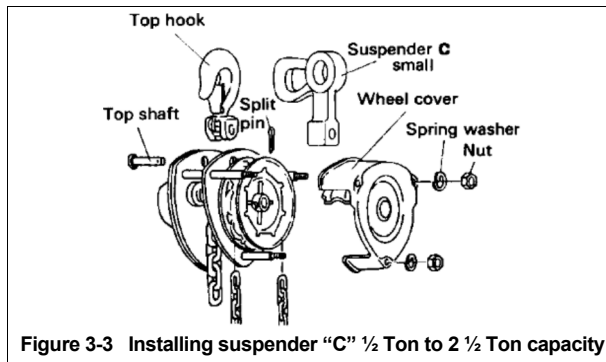

- 7) For 3 to 5 Ton capacity Refer to **Figure 3-4**.

- 8) Remove the wheel cover nuts and lock washers, then remove wheel cover.
- 9) Straighten and remove the spit pin in the top shaft pin and remove the top shaft pin, remove the top hook.
- 10) Mount suspender "C" (large) in place of the top hook, insert the top shaft pin and re-insert the split pin.
- 11) Replace the wheel cover.
- 12) Attach Hoist to Trolley.

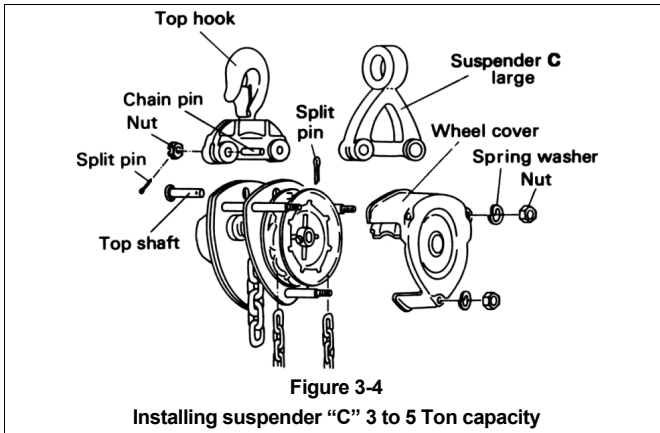

- 3.1.3 For 8 and 10 Ton capacities, Harrington's Model CB Series chain hoists is hook mounted directly to the suspension shaft of the TF/TS Trolley as shown in **Figure 3-5**. Since the hoist is directly hook mounted, no additional hoist preparation is necessary. See **Section 3.4** for more information on trolley assembly.
- 3.1.4 For 15 and 20 Ton capacities, Harrington's Model CB Series chain hoist is hook mounted to a suspension shaft which is connected to a pair of side plates. The side plates are mounted to the TF/TS trolley using two additional suspension shafts as shown in **Figure 3-6**. Since the hoist is directly hook mounted, no additional hoist preparation is necessary. See **Section 3.4** for more information on trolley assembly.

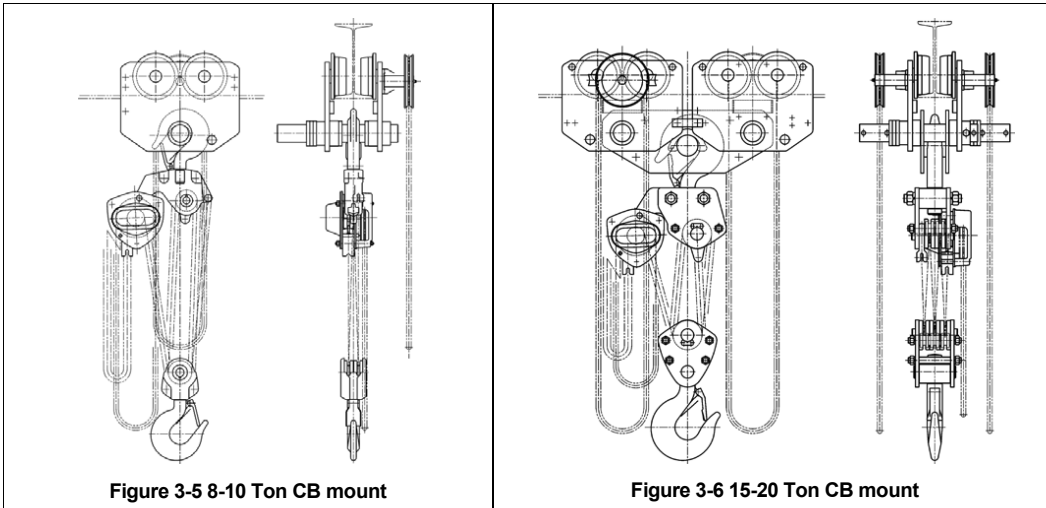

3.1.5 Harrington Model CF Series hoists can be hook mounted to the TF2 trolley using suspender "C" or optional suspender "H" ½ Ton to 3 Ton, as shown in **Figure 3-7**. 5 Ton models hook to the trolley shaft, as shown in **Figure 3-8**.

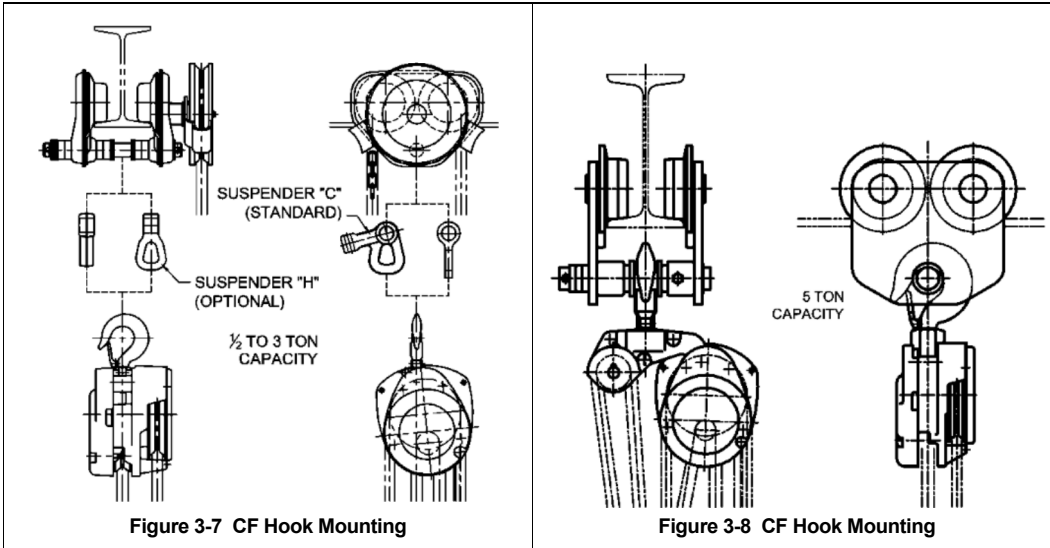

3.2 Electric Hoist Adjustment for Trolley

⚠ DANGER

HAZARDOUS VOLTAGES ARE PRESENT IN THE HOIST CONTROL BOX, IN THE SUPPLY OF ELECTRICAL POWER TO THE HOIST MOTOR.

Before performing ANY mechanical or electrical maintenance on the equipment, de-energize (disconnect) the main switch supplying power to the equipment; and lock and tag the main switch in the de-energized position. Refer to ANSI Z244.1, "Personnel Protection – Lockout/Tagout of Energy Sources".

Only trained and competent personnel should inspect and repair this equipment.

3.2.1 **⚠ DANGER** Never attempt to hook mount an Electric chain hoist directly to the Suspension Shaft on trolleys up to and including 3 Ton. These trolleys are designed to be used with a suspender only and do not have the vertical clearance required for a hook to fit between the Suspension Shaft and trolley beam.

- 3.2.2 When the TS2 trolley is combined with a hoist, follow and complete all pre-operational procedures provided with the hoist. For Harrington SH, ES and NES model hoists, follow the pre-operational procedures in the SH, ES/NES Owner's Manual in conjunction with all information provided in this section for mounting and electrical connections.
- 3.2.3 In addition to the information and procedures provided in this section for the TS2 trolley, there are specific details for using SH, ES and NES hoists with TS2 trolleys. Special mounting and wiring considerations must be taken if the trolley is used with a hoist other than an SH, ES or NES model.
- 3.2.4 Preparing SH, ES and NES hoists for use with TS2 trolley.
- 1) These instructions pertain to the mechanical coupling of the hoist to the trolley. Refer to the hoists owner's manual for the Electrical connections.
 - 2) SH & ES Series Hoists couple directly to the trolley with suspender "E", as shown in **Figure 3-9** and **Figure 3-10**.

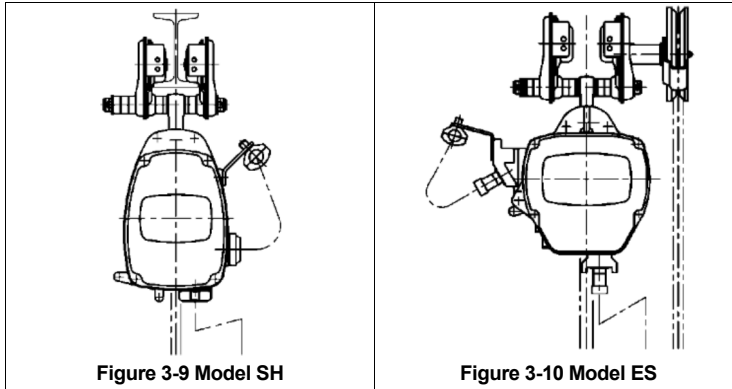

- 3) Refer to the appropriate product owner's manual parts list and associated diagrams for the hoist.
- 4) Single Fall Units – Remove the Top Hook assembly by removing the Split Pin from the Slotted Nut. Remove the Slotted Nut, pull out the Top Pin, and remove the Top Hook. Replace with Suspender E, replace Top Pin, Slotted Nut and Split Pin. Be sure to bend Split Pin ends of the Split Pin away from each other sufficiently so the Split Pin remains captive in the Top Pin. Refer to **Figure 3-11** or **Figure 3-12** for the appropriate product. Attach hoist to the trolley.
- 5) Double Fall Units (except 5 Ton ES) – Remove the Top Hook assembly by removing the Split Pin from the Slotted Nut. Remove the Slotted Nut, pull out the Top Pin L from the Connection Yoke, and remove Top Hook. Replace with Suspender E, replace Top Pin, Slotted Nut and Split Pin. Be sure to bend Split Pin ends of the Split Pin away from each other sufficiently so the Split Pin remains captive in the Top Pin. Refer to **Figure 3-11** or **Figure 3-12** for the appropriate product. Attach hoist to the trolley.
- 6) 5 Ton ES – This hoist couples to the trolley by hook mounting the hoist to the trolley's suspension shaft. As shown in **Figure 3-13**.

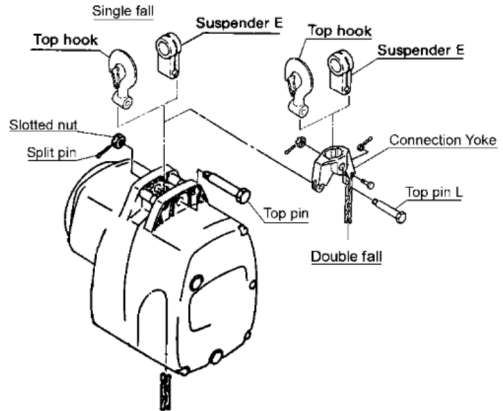

Figure 3-11 Model SH

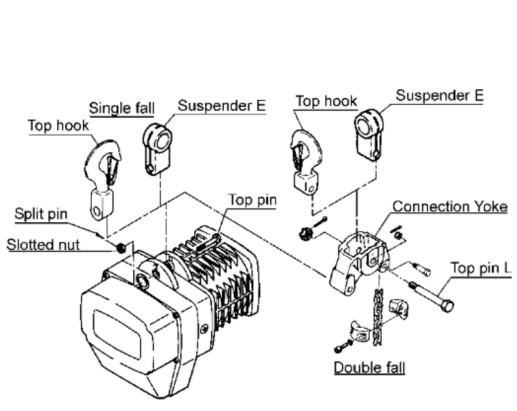

Figure 3-12 Model ES

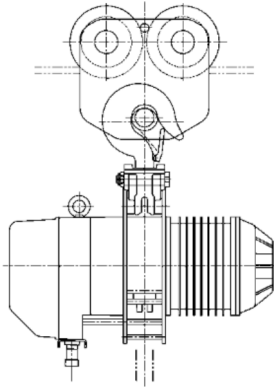

Figure 3-13 Model 5 Ton ES

3.2.5 To Couple a 1/8-5 Ton Model ER Electric chain hoist to a TF2/TS2 trolley, access to the ER Electrical controls is required. Refer to **Figure 3-14** or **Figure 3-15**, proceed as follows.

 **DANGER**

HAZARDOUS VOLTAGES ARE PRESENT IN THE HOIST CONTROL BOX, IN THE SUPPLY OF ELECTRICAL POWER TO THE HOIST MOTOR.

Before performing ANY mechanical or electrical maintenance on the equipment, de-energize (disconnect) the main switch supplying power to the equipment; and lock and tag the main switch in the de-energized position. Refer to ANSI Z244.1, "Personnel Protection – Lockout/Tagout of Energy Sources".

Only trained and competent personnel should inspect and repair this equipment.

- 3.2.6 When the TF2/TS2 trolley is combined with a hoist, follow and complete all pre-operational procedures provided with the hoist. For Harrington's ER and NER model hoists, follow the pre-operational procedures in the ER/NER Owner's Manual in conjunction with all information provided in this section for mounting and electrical connections.
- 3.2.7 In addition to the information and procedures provided in this section for the TS2 trolley, there are specific details for using ER and NER hoists with TF2/TS2 trolleys. Special mounting and wiring considerations must be taken if the trolley is used with a hoist other than an ER or NER model.
- 3.2.8 Preparing ER and NER hoists for use with TF2/TS2 trolley.

1/8 to 3 Ton ER/NER (EXCEPT 030C) – Assuming the hoist has an existing Top hook.

- 1)** Refer to **Figure 3-14**.
- 2)** Remove the four Controller Cover socket head bolts and allow the cover to swing fully open.
- 3)** Loosen the three or four captive screws holding the electrical component mounting Plate against the main body of the hoist and swing the plate out to access the required components.
- 4)** Loosen one of two Machine Screws attaching Plate A and remove the second Machine Screw. Allow Plate A to rotate out from the retaining slot in the bottom side of the Connection Shaft. Pull out the Connection Shaft and remove the Top Hook Assembly.
- 5)** Remove the Hoist Fixing Shaft.
- 6)** Installing the Connection Yoke, place the Connection Yoke Rubber and Suspender E in the top of the Connection Yoke. Attach Suspender E to the Connection Yoke with the Yoke Bolt, Slotted Nut and Split Pin (cotter pin).
- 7)** Place Connection Yoke with Suspender E on the top of the hoist. Line up the holes for the Connection Shaft and the Hoist Fixing Shaft and reinsert the shafts.
- 8)** Reassemble the remaining hoist components in reverse order of disassembly.

3 Ton (030C) and 5 Ton ER/NER – The 3 Ton (030C) and 5 Ton ER/NER hoists (double fall) always use a Connection Yoke. Remove the Top Hook Assembly from the Connection Yoke and install the Suspender E shown in **Figure 3-15**.

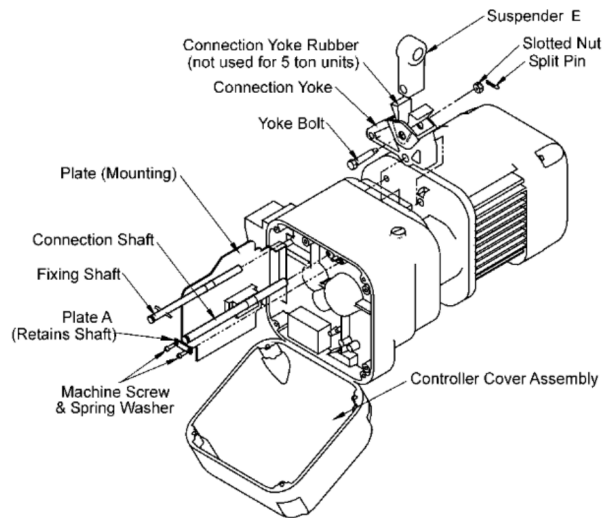
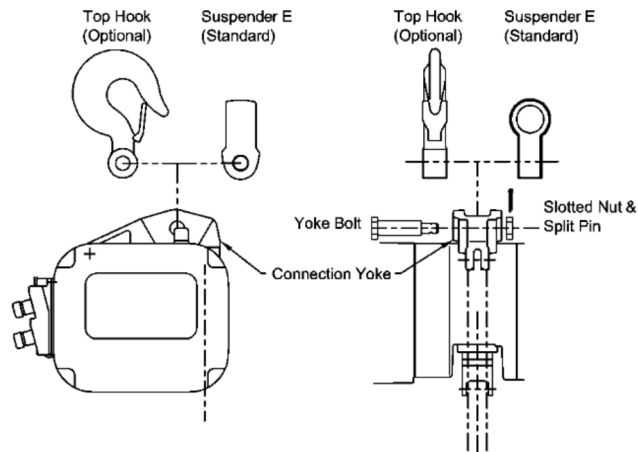

Figure 3-14 Installing Connection Yoke with Suspenders E on ER Hoists – Connection Yoke standard on 030C & 050 models



Note: Unlike 3 Ton (Single Fall) and below (see Figure 3-12), Suspenders G for 3 Ton (030C) and 5 Ton connects directly to the Connection Yoke without the Connection Yoke Rubber.

Figure 3-15 Installing Suspenders E or G on 3 Ton (030C) and 5 Ton ER Hoists

8 to 20 Ton ER/NER – Since the trolley suspension shaft(s) passes through the hoist top plates, no additional hoist preparation is required to mount the (N)ER hoist to the trolley. Refer to **Figure 3-16** and **Figure 3-17**. See **Section 3.4** for more information on trolley assembly.

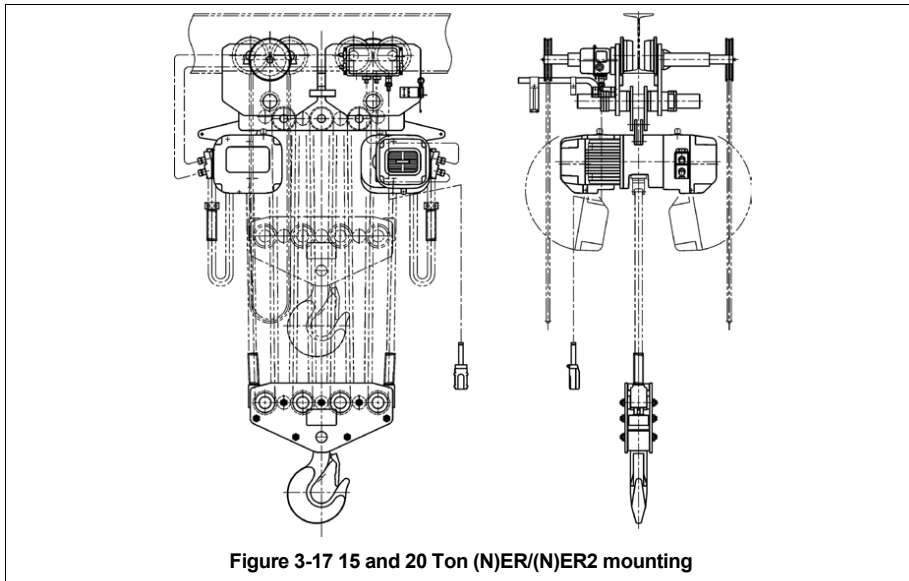
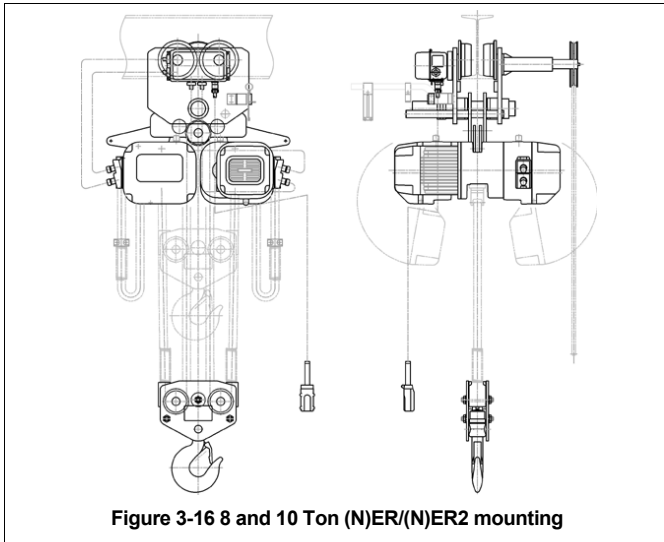

3.2.9 Preparing ED1050S/DS hoists for use with TS2 trolley.

- 1) These instructions pertain to the mechanical coupling of the hoist to the trolley. Refer to the hoist's owner's manual for the electrical connections.
- 2) The standard configuration for ED1050S/DS hoists is to couple the hoist directly to the trolley with Suspender "E", as shown in **Figure 3-18**.
- 3) Refer to the appropriate product owner's manual parts list and associated diagrams for the hoist.
- 4) Refer to **Figure 3-18**. Remove the Top Hook assembly by removing the Split Pin from the Slotted Nut. Remove the Slotted Nut, pull out the Top Pin, and remove the Top Hook. Replace with Suspender E, replace Top Pin, Slotted Nut and Split Pin. Be sure to bend Split Pin ends of the Split Pin away from each other sufficiently so the Split Pin remains captive in the Top Pin. Attach hoist to the trolley.

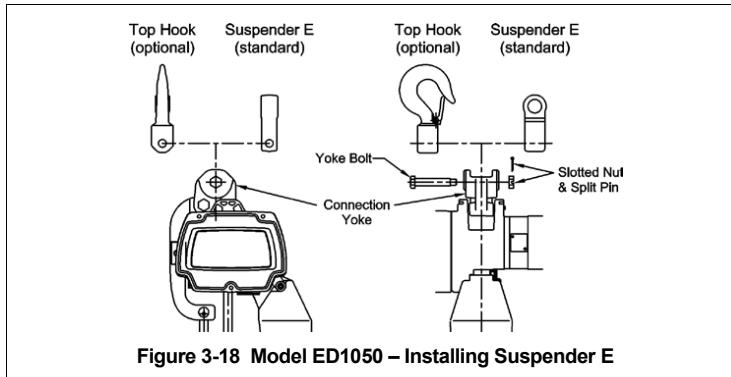

3.2.10 Prepare the ER2 and NER2 hoists for use with TF2/TS2 trolley for the following hoists:

001H, 003S, 003H, 005L, 005S, 010L, 010S, 015S, 020C, 020L, 020C, 030C

- 1) Refer to **Figure 3-19**.
- 2) Remove the Shaft Retainer Clip from the two Connection Shafts.
- 3) Remove the Socket Bolt from the Shaft Retainer.
- 4) Remove the two Connection Shafts.
- 5) Remove the Top Hook and replace it with the Connection Yoke.
- 6) Re-insert the two Connection Shafts, so that both pass through the main body and the shaft holes of Connection Yoke.
- 7) Re-install the Shaft Retainer, Socket Bolt, and Shaft Retainer Clip.
- 8) Install the appropriate Suspender for the application, securing it to the Connection Yoke with the Yoke Bolt, Slotted Nut, and Split Pin. **Note: (See Figure 3-19) Double Fall applications require a Chain Pin, small Slotted Nut, and small Split Pin, in addition to the Yoke Bolt, Slotted Nut, and Split Pin.**

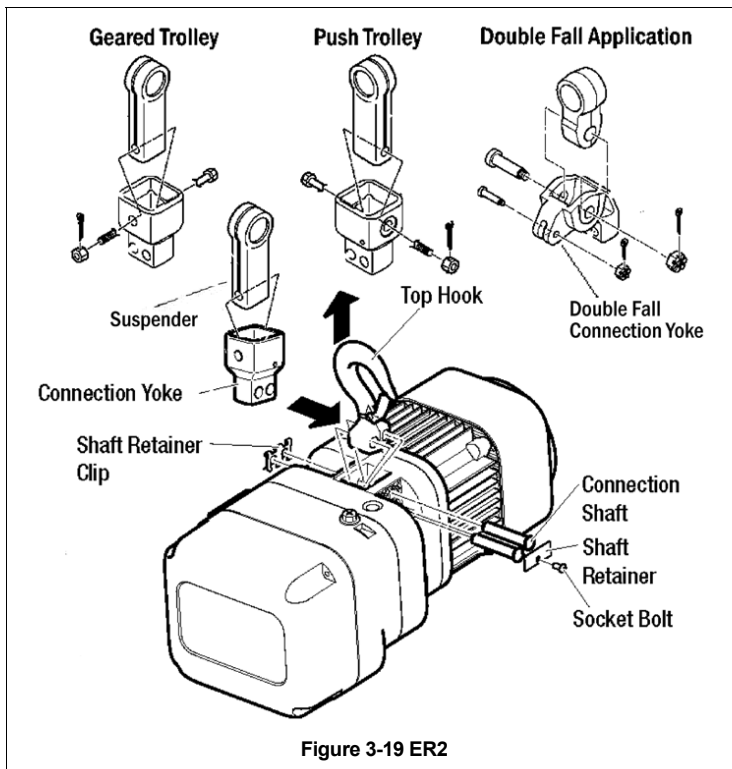

Figure 3-19 ER2

3.2.11 Prepare ER2 and NER2 hoists for use with TF2/TS2 trolley for the following hoists:

025S and 050L

- 1) Refer to **Figure 3-20**
- 2) Remove the four Socket Bolts that hold the Controller Cover to the hoist body. Now the Controller Cover can be lowered and left to hang by the cover belt.
- 3) Remove the four pan head screws and the two Shaft Retainers. This will allow the Bracing Shaft and the Connection Shaft to be removed by sliding them out of the hoist body.
- 4) With the Connection Shaft and Bracing Shaft removed, the Top Hook can be removed and replaced with the appropriate Connection Yoke.
- 5) Re-insert the Connection Shaft and Bracing Shaft ensuring both pass through the Connection Yoke flange.
- 6) Fix the Connection Shaft and Bracing Shaft with their respective Shaft Retainer and pan head screws.
- 7) Install appropriate Suspender for the application, securing it to the Connection Yoke with the Yoke Bolt, Slotted Nut, and Slit Pin. **Note: (See Figure 3-20) Double Fall applications require a Chain Pin, small Slotted Nut, and small Split Pin, in addition to the Yoke Bolt, Slotted Nut, and Split Pin.**
- 8) Re-install Controller Cover with the four Socket Bolts.

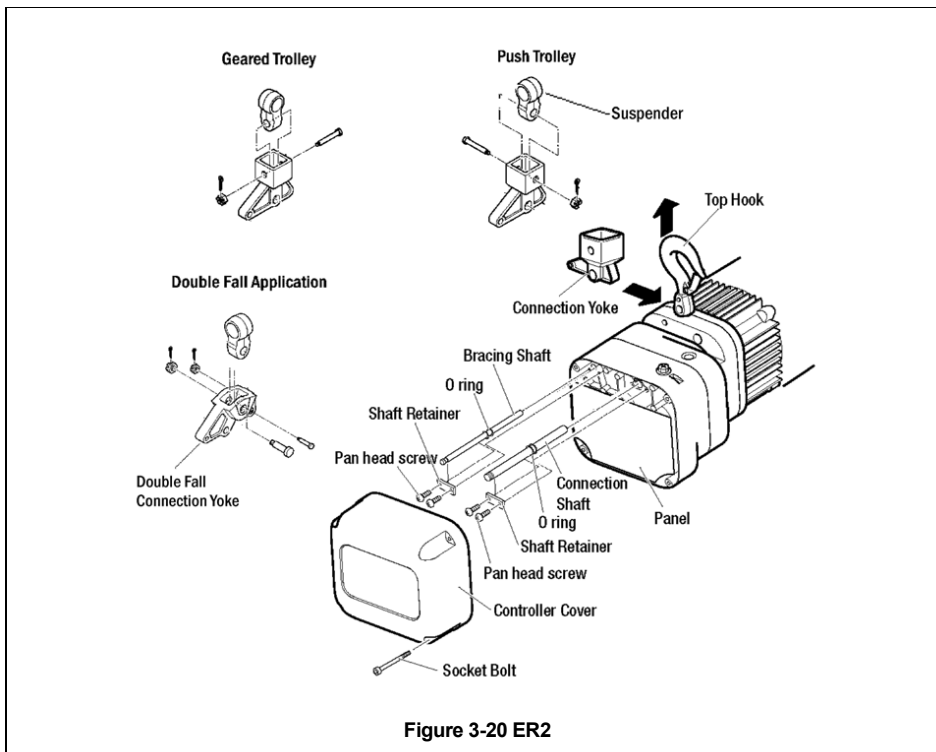

Figure 3-20 ER2

8 to 20 Ton ER2/NER2 – Since the trolley suspension shaft(s) passes through the hoist top plates, no additional hoist preparation is required to mount the (N)ER2 hoist to the trolley. Refer to **Figure 3-16** and **Figure 3-17** which apply to both (N)ER and (N)ER2. See **Section 3.4** for more information on trolley assembly.

3.2.12 Prepare the EQ and SEQ hoists for use with TF2/TS2 trolley for the following hoists:

The standard suspension configuration, with a trolley, uses the Suspension Bar which orients the hoist perpendicular to the trolley beam. If the hoist is not equipped with the Suspension Bar, remove the Top Hook Assembly from the hoist and install the Suspension Bar as follows in step **1 through 4**. Optional hook mount to Suspender H orients the hoist parallel to the trolley beam.

- 1) Refer to **Figure 3-21**.
- 2) Remove the Screws. Remove Top Pins.
- 3) Remove the Top Hook Assembly and replace it with the Suspension Bar.
- 4) Reinstall the Top Pins and Screws

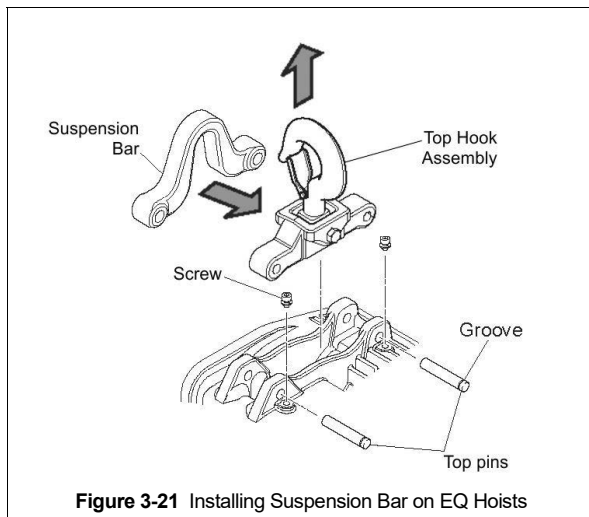

3.3 Air Powered Hoist Adjustment for Trolley

- 3.3.1 Coupling a TCR, TCS, TCK, or TCL Air Hoist to a TF2/TS2 Trolley.
- 3.3.2 When the TF2/TS2 trolley is combined with a hoist, follow and complete all pre-operational procedures provided with the hoist. For Harrington TCR/S/K/L model hoists, follow the pre-operational procedures in the TCR/S/K/L Owner's Manual in conjunction with all information provided in this section for mounting and air hose connections.
- 3.3.3 In addition to the information and procedures provided in this section for the TF2/TS2 trolley, there are specific details for using TCR/S/K/L hoists with TF2/TS2 trolleys. Special mounting and air hose considerations must be taken if the trolley is used with a hoist other than a TCR/S/K/L model.
- 3.3.4 Standard configuration for a TCR/S/K/L hoist is lug mounted to the trolley using a TCR/K/L Suspenders. As shown in **Figure 3-21** or **Figure 3-22**.
- 3.3.5 Preparing TCR/K/L hoists for use with TF2/TS2 trolley.

For Single fall hoists (*TCR/S/L250P, *500P, 1000P, 3000P, TCK/L3000) - Refer to **Figure 3-23**.

* TCR/S/L250 & 500 use a TF2010 trolley. Hoists WILL NOT FIT on TF2005 trolley.

Remove the Top Hook Assembly from the hoist and install the suspender as follows:

- 1) Remove the top pin, yoke and top hook.
- 2) To remove the top pin, yoke and top hook on the TCR1000P loosen and remove the 3 bolts holding the gear section onto the main body. Rotate the gear section clockwise to allow the top pin to be removed.
- 3) Place the suspender on the top of the hoist. Line up the holes for the hoist main body and suspender. Reinsert the top pin.
- 4) Reassemble the remaining hoist components in reverse order of disassembly.

For Double fall hoists (TCR/S/L1000P2, TCR2000P2, TCR6000P2, TCK/L6000) - Refer to **Figure 3-24**.

Remove the Top Hook Assembly and Load Chain from the hoist and install the suspender as follows:

- 1) Loosen and remove the bolt attaching the load chain to the top hook yoke.
- 2) Remove the load chain from the top hook yoke.
- 3) Remove the top pin, yoke and top hook.
- 4) To remove the top pin, yoke and top hook on the TCR2000P2 loosen and remove the 3 bolts holding the gear section onto the main body. Rotate the gear section clockwise to allow the top pin to be removed.
- 5) Place the suspender on the top of the hoist. Line up the holes for the hoist main body and suspender. Reinsert the top pin.
- 6) Reassemble the remaining hoist components in reverse order of disassembly
- 7) Reattach the no load side of the load chain to the load chain mounting hole in the suspender.

For Double fall hoist (TCR10000P2) - Refer to **Figure 3-25**

Remove the Top Hook Assembly from the hoist and install the suspender as follows:

- 1) Loosen and remove the two top pins that connect the top hook assembly to the hoist body.
- 2) Remove the top hook assembly.
- 3) Place the suspender on the top of the hoist and line up the holes with the main hoist body.
- 4) Reinstall the two top pins through the hoist body and suspender.

3.3.6 Coupling an AL Air Hoist to a TS2 Trolley.

- 1) When the TS2 trolley is combined with a hoist, follow and complete all pre-operational procedures provided with the hoist. For Harrington AL model hoists, follow the pre-operational procedures in the AL Owner's Manual in conjunction with all information provided in this section for mounting and air hose connections.
- 2) Standard configuration for an AL hoist is hook mounted to suspender C of the trolley, similar to **Error! Reference source not found.**

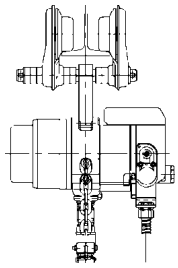

Figure 3-21 Lug mount on TF2

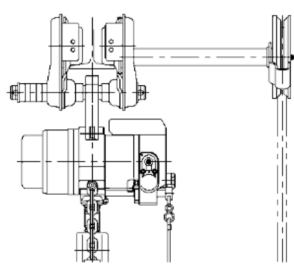
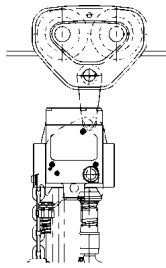

Figure 3-22 Lug mount on Geared TS2 Extended Hand Wheel

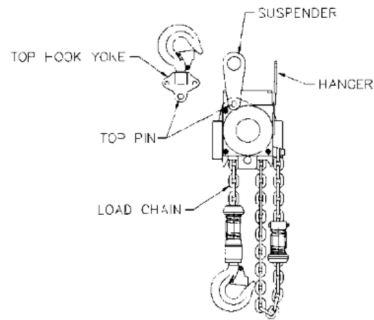
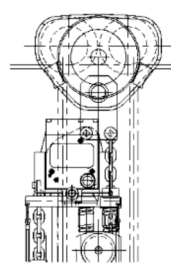

Figure 3-23 Installing Suspender on single fall hoists TCR/S/L250P, 500P, 3000P, and TCK3000

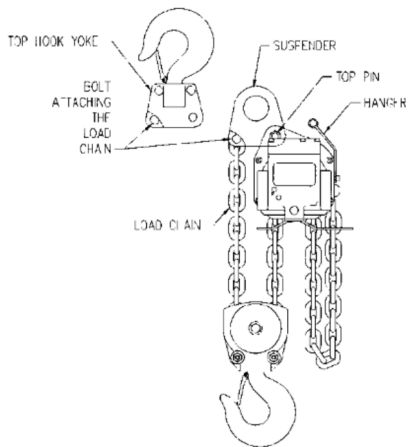

Figure 3-24 Installing Suspender on double fall hoists TCR/S/L1000P, TCR2000P2, TCR/K/L6000P2

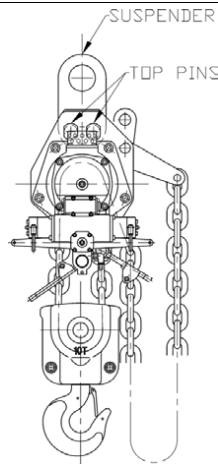

Figure 3-25 Installing Suspender on TCR1000P2

3.3.7 When using an optional steel chain container, refer to the assembly drawing and instructions provided with the container for correct assembly and attachment.

3.4 Trolley Assembly

Refer to **Figure 3-26** for ½ through 3 Ton.

Refer to **Figure 3-27** for 5 Ton.

- 1) Remove the Shaft Stopper Pin, Side Plate SN, and Spacers from the Suspension Shaft. For beam flanges that are wider than the standard range, different suspension shaft and/or spacer arrangements are provided. Refer to **Table 3-1**.
- 2) Insert the Suspension Shaft to Side Plate G or S and attach it with the Shaft Stopper Pin and Split Pin (cotter pin). Refer to **Figure 3-32** to ensure that the correct Suspension Shaft holes are used. Securely bend both branches of the Split Pin after insertion.
- 3) Referring to **Figure 3-34**, **Table 3-1** and **Table 3-2** install the inner adjusting Spacers and Suspender on the Suspension Shaft. Use all of the Spacers provided with the trolley. If the beam width is not listed in the Table, use the next size smaller and make adjustments in accordance with **Section 3.3.8**.
- 4) Place Side Plate SN into the Suspension Shaft.
- 5) Install the outer adjusting Spacers on the Suspension Shaft outside of Side Plate SN. Insert the Shaft Stopper Pin into Suspension Shaft. Temporarily install the split pin in the Shaft Stopper Pin and bend the split pin slightly to hold it in place. The split pin should be fully bent after checking and attaining the proper beam flange adjustment

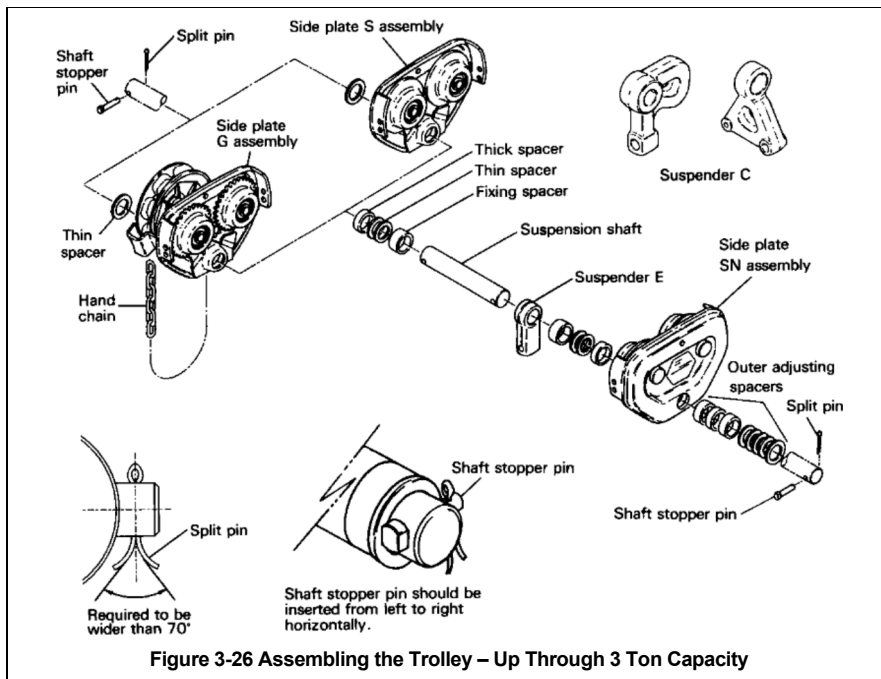

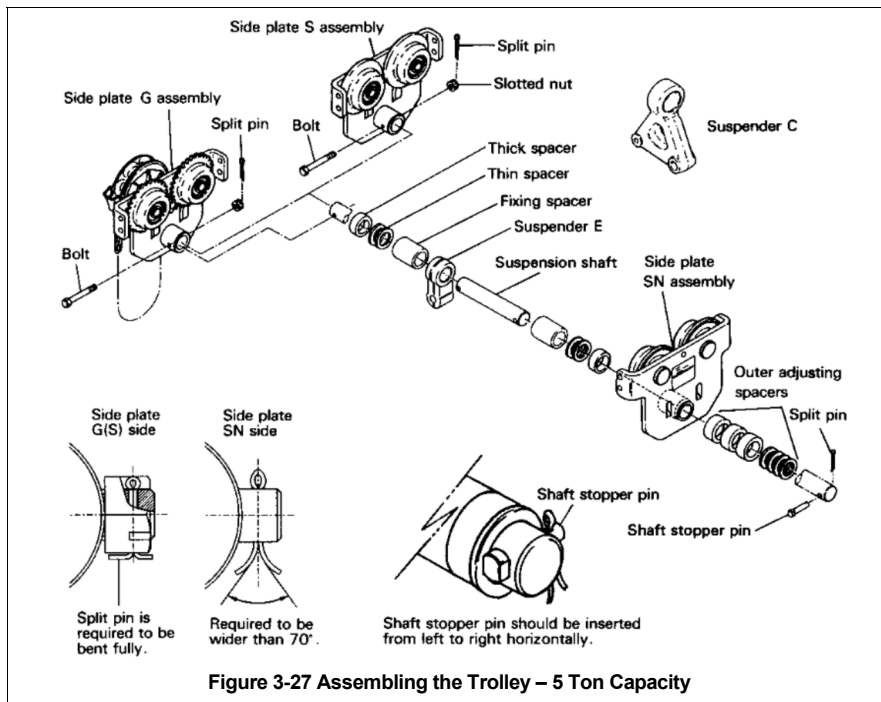

Refer to **Figure 3-28** for 8 to 10 Ton coupled with Manual CB hoist

Refer to **Figure 3-28** for 6 and 10 Ton coupled with a TCR air hoist except the applicable TCR suspender will be used instead of the top hook (See Table 2-12 and Section 3.3 for TCR suspender information).

Refer to **Figure 3-29** for 8 to 10 Ton coupled with (N)ER/(N)ER2 hoist

- 1) Remove the Shaft Stopper Pin, Side Plate S, and Spacers from the Suspension Shaft. For beam flanges that are wider than the standard range, different suspension shaft and/or spacer arrangements are provided. Refer to **Table 3-1**.
- 2) Insert the Suspension Shaft to Side Plate G and attach it with the Suspension Shaft Bolt, Slotted Nut and Split Pin (cotter pin). Refer to **Figure 3-32** to ensure that correct Suspension Shaft holes are used. Securely bend both branches of the Split Pin after insertion.
- 3) Referring to **Figure 3-34** and **Table 3-3** install the inner adjusting Spacers and Suspender (for TCR) or Suspension Plates (for (N)ER/(N)ER2) on the Suspension Shaft. For CB hoist, the hook can be attached after assembly. Use all of the Spacers provided with the trolley. If the beam width is not listed in **Table 3-3**, use the next size smaller and make adjustments in accordance with **Section 3.3.8**.
- 4) Place Side Plate S onto the Suspension Shaft.
- 5) Install the outer adjusting Spacers on the Suspension Shaft outside of Side Plate S. Refer to **Figure 3-32** and insert the Shaft Stopper Pin into hole "A." Temporarily install the split pin in the Shaft Stopper Pin and bend the split pin slightly to hold it in place. The split pin should be fully bent after checking and attaining the proper beam flange adjustment.

- 6) For the (N)ER/(N)ER2 hoists – Insert the Trolley Fixing Shaft through Side Plate G, Suspension plates and Side Plate S. Refer to **Figure 3-29**. Secure it to side Plate G with two split pins. Securely bend both branches of the Split Pin after insertion.

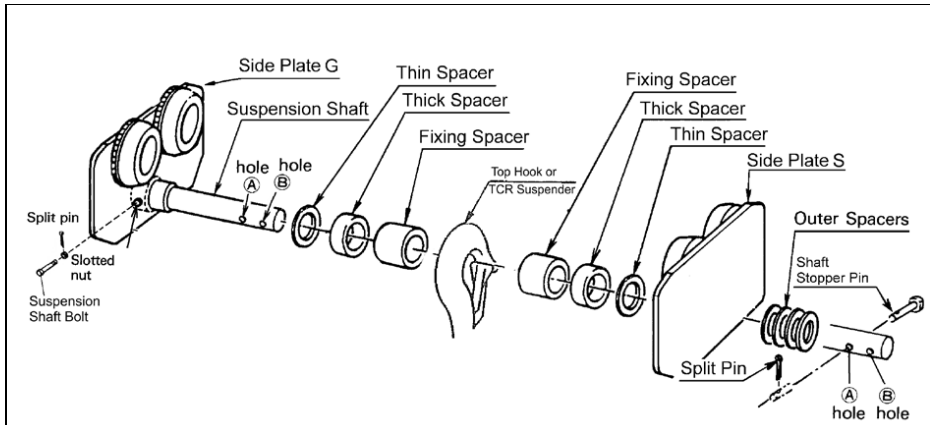

Figure 3-28 Assembling the Trolley - 8 Through 10 Ton Capacity, CB or TCR

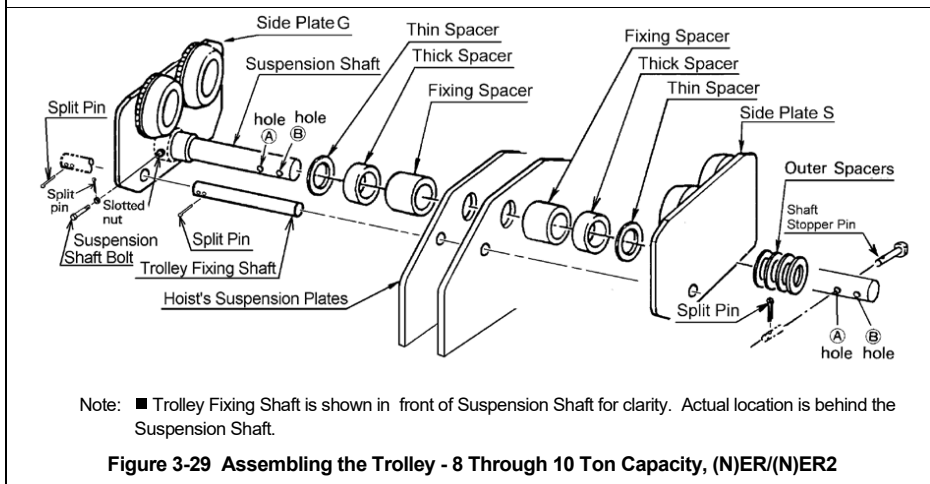

Figure 3-29 Assembling the Trolley - 8 Through 10 Ton Capacity, (N)ER/(N)ER2

Refer to **Figure 3-30** for 15-20 Ton coupled with Manual CB hoist

Refer to **Figure 3-31** for 15-20 Ton coupled with (N)ER/(N)ER2 hoist

- 1) Remove the Shaft Stopper Pin, Side Plate S, and Spacers from the Suspension Shaft. For beam flanges that are wider than the standard range, different suspension shaft and/or spacer arrangements are provided. Refer to **Table 3-1**.

- 2) Insert the Suspension Shaft to Side Plate G and attach it with the Suspension Shaft Bolt, Slotted Nut and Split Pin (cotter pin). Refer to **Figure 3-32** to ensure that correct Suspension Shaft holes are used. Securely bend both branches of the Split Pin after insertion.
- 3) Referring to **Figure 3-34** and **Table 3-3** install the inner adjusting Spacers, Suspension plates, and Side Plate S on the Suspension Shaft. Use all of the Spacers provided with the trolley. If the beam width is not listed in **Table 3-2**, use the next size smaller and make adjustments in accordance with Section 3.3.8.
- 4) Place Side Plate S onto the Suspension Shaft.
- 5) Install the outer adjusting Spacers on the Suspension Shaft outside of Side Plate S. Insert the Shaft Stopper Pin into Suspension Shaft. Temporarily install the split pin in the Shaft Stopper Pin and bend the split pin slightly to hold it in place. The split pin should be fully bent after checking and attaining the proper beam flange adjustment.

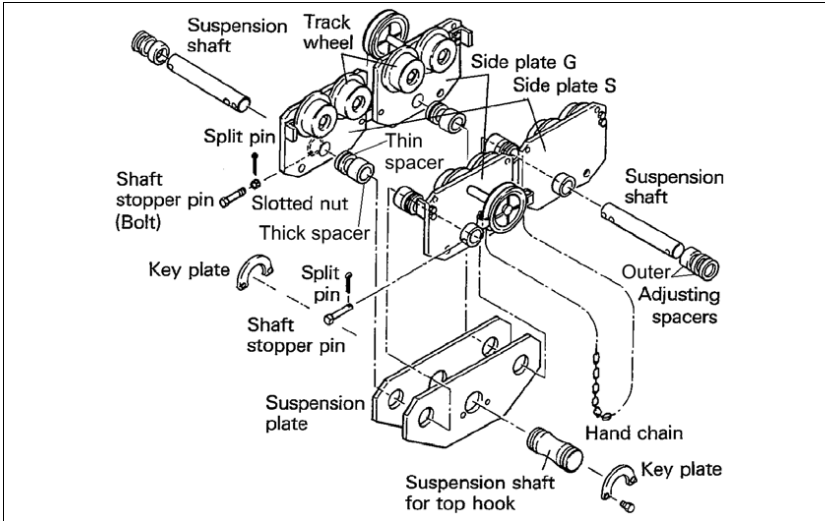

Figure 3-30 Assembling the Trolley – 15-20 Ton Capacity (Manual)

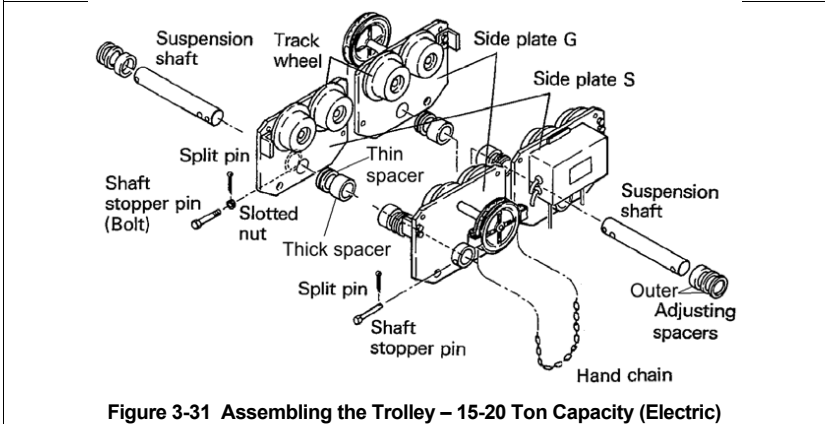
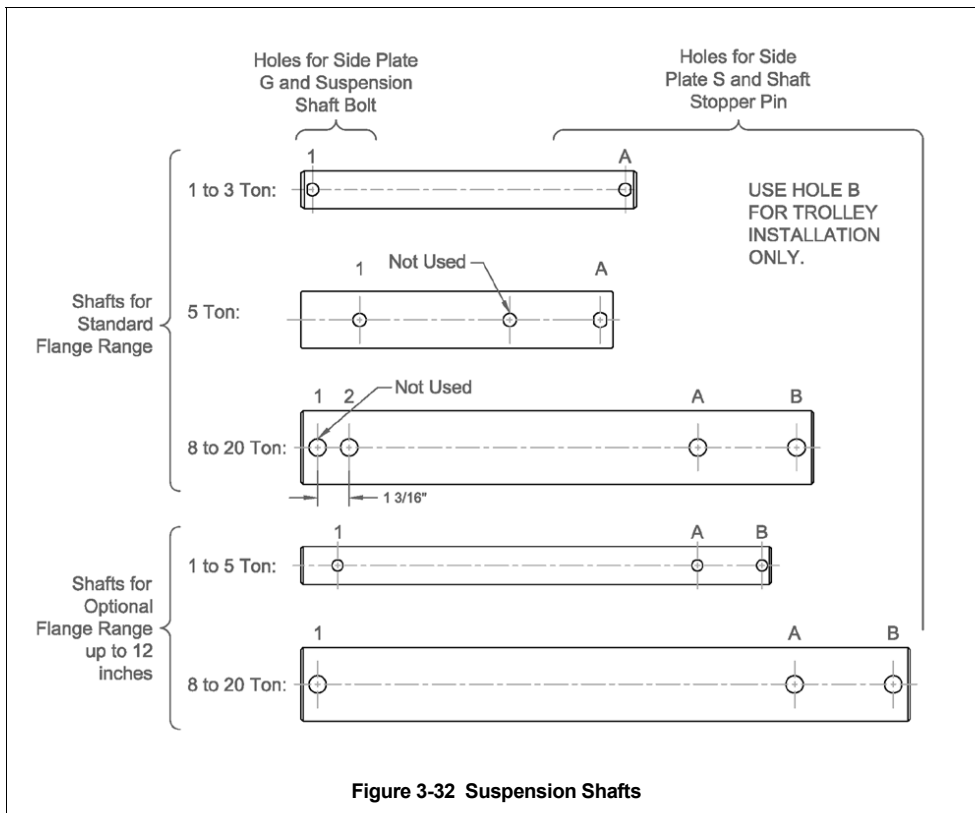

Figure 3-31 Assembling the Trolley – 15-20 Ton Capacity (Electric)



3.4.1 Adjusting the trolley width – After assembling trolley per **Section 3.5**, check the adjustment as follows:

- 1) Refer to **Figure 3-33**.
- 2) Make sure both side plates are spread fully outward and measure dimension "A". Compare dimension "A" with the following values:
 - For trolleys up through 5 Ton, "A" must be $\frac{3}{32}$ " to $\frac{5}{32}$ " greater than "B".
 - For trolleys 8 Ton to 20 Ton, "A" must be $\frac{3}{16}$ " to $\frac{1}{4}$ " greater than "B".
- 3) If "A" does not fall within the specified range, move spacers from inner to outer or from outer to inner as necessary to obtain the proper "A" dimension, irrespective of the numbers in **Table 3-2**.
- 4) After obtaining the proper adjustment, install the Shaft stopper Pin, insert the Split Pin into the Stopper Shaft Pin, and securely bend both branches of the Split Pin.
 - **▲ WARNING** For trolleys 8 Ton to 20 Ton, make sure to insert Shaft Stopper Pin into Hole "A". HOLE "B" IS FOR TROLLEY INSTALLATION ONLY.
- 5) Because two traversing units are combined in the 15 and 20 Ton trolley, ALWAYS adjust both units in the same way.

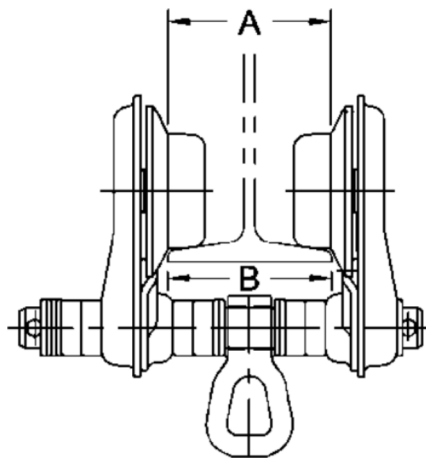
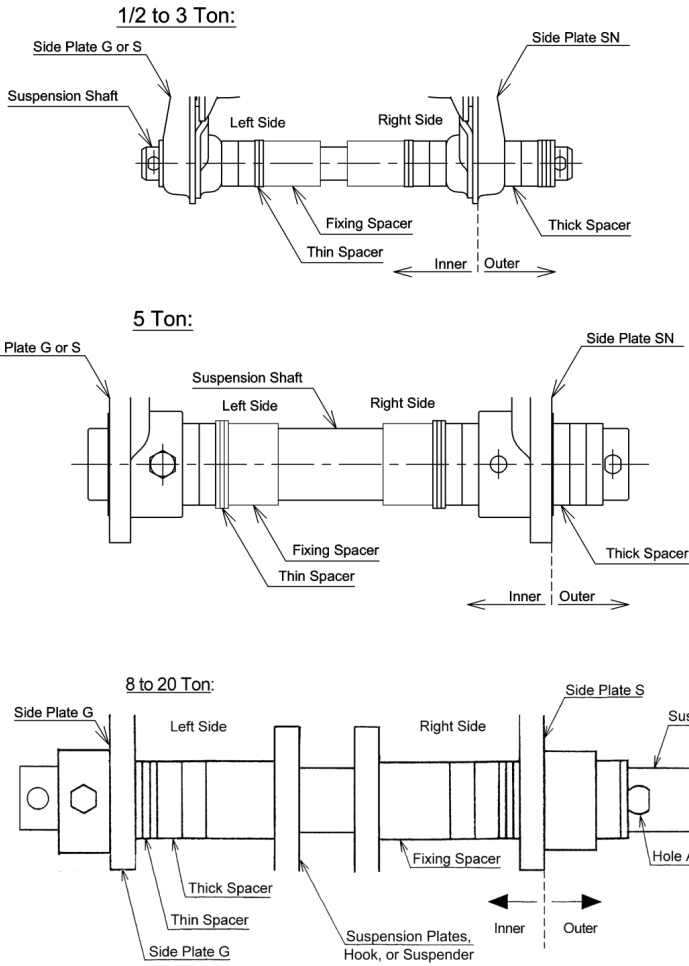

Figure 3-33 Adjusting the Trolley



Note: Inner Spacer rows on **Table 3-2** and **Table 3-3** list two numbers. The first number is the quantity of spacers located on the left side of the Suspender or Suspension Plates, the second number is the quantity on the right side.
 Example: 1 + 2 ← Adjusting Spacers on the right side [Side Plate SN side (for 8 to 20 Ton, Side Plate S side)] ↑ Adjusting Spacers on the left side [Side Plate G or S side (for 8 to 20 Ton, Side plate G side)]

Figure 3-34 Spacers Arrangement

Table 3-1 Suspension Shaft Adjusting Spacers						
Capacity (Tons)	Flange Range (in)	Total Number of Spacers Supplied				
		Thin	Thick	Fixing	Thick L	Balancing Collar (5 Ton only)
1/2	2.28 to 4.00	10 (12) ^q	4	—	—	—
	4.01 to 8.00	10 (12) ^q	7	2	—	—
	8.01 to 12.00	10 (12) ^q	7	2	—	—
1	2.28 to 5.00	9 (11) ^q	6	—	—	—
	5.01 to 8.00	10 (11) ^q	5	2	—	—
	8.01 to 12.00	10 (11) ^q	7	2	—	—
2	3.23 to 6.02	8	6	—	—	—
	6.03 to 12.00	10	11	2	—	—
3	3.23 to 6.02	11	9	—	—	—
	6.03 to 12.00	10	11	2	—	—
TF 5	3.94 to 7.02	8	3	—	2	—
	7.03 to 12.00	8	11	—	2	2
TS 5	3.94 to 7.02	8	5	—	—	—
	7.03 to 12.00	8	9	2	—	—
8	5.50 to 9.02	8	8	—	—	—
	9.02 to 12.00	8	9	2	—	—
10	5.50 to 9.02	8	8	—	—	—
	9.02 to 12.00	8	9	2	—	—
15*	5.50 to 9.02	10**	3	—	—	—
	9.02 to 12.00	8	11	—	—	—
20*	5.50 to 9.02	10**	3	—	—	—
	9.02 to 12.00	8	11	—	—	—

*Note: 15 and 20 Ton models have two suspension shafts. The number of spacers above reflects the quantities per suspension shaft.

**For flange widths between 5 1/2 to 5 7/8, three (3) additional thin spacers are required (for a total of 13 thin spacers).

q – When coupling an EQ/SEQ to TS trolley with the Suspension Bar, an additional 2 thin spacers will be provided. They should be installed evenly on either side of the suspension bar.

Table 3-2 Number of Adjusting Spacers, 1/2 to 5 Ton

Beam Flange Width		(in)	2	2 5/16	2 1/2	2 7/8	3	3 1/4	3 9/16	3 7/8	3 15/16	4	4 3/16	4 15/16	4 7/16	4 11/16	4 13/16	5	5 3/16	5 5/16	5 3/8	5 1/2	5 5/8	5 7/8	6	6 1/8	6 5/16	6 7/16	
Cap (Ton)	Spacer Type	(mm)	50	58	64 66	73 74	75 76	82	90 91	98	100	102	106	110	113	119 120	125	127	131	135	137	140	143	149 150	153	155	160	163	
1/2	Thin ^q	Inner	2+3	3+4	0+1	1+2	2+2	3+3	0+1	1+2	2+2	2+3	1+1	1+2	2+2	3+3	0+0	0+1	1+1	1+2	2+2	2+3	3+3	0+0	0+1	1+1	1+2	2+2	
		Outer	4	2	8	6	5	3	8	6	5	4	7	6	5	3	9	8	7	6	5	4	3	9	8	7	6	5	
	Thick	Inner	0+0	0+0	1+1	1+1	1+1	1+1	2+2	2+2	2+2	2+2	0+0	0+0	0+0	0+0	1+1	1+1	1+1	1+1	1+1	1+1	1+1	1+1	2+2	2+2	2+2	2+2	2+2
		Outer	4	4	2	2	2	2	0	0	0	0	7	7	7	7	5	5	5	5	5	5	5	5	3	3	3	3	3
	Fixing	Inner	-	-	-	-	-	-	-	-	-	-	1+1	1+1	1+1	1+1	1+1	1+1	1+1	1+1	1+1	1+1	1+1	1+1	1+1	1+1	1+1	1+1	1+1
1	Thin ^q	Inner	3+3	0+0	1+1	1+2	2+3	0+0	1+1	1+2	1+2	2+3	3+3	3+4	0+1	1+2	2+2	1+1	1+2	2+2	2+3	3+3	0+0	0+1	1+1	1+1	1+1	1+1	1+1
		Outer	2	8	6	5	3	8	6	5	4	3	2	1	7	5	4	7	6	5	4	3	9	8	7	6	5		
	Thick	Inner	0+0	1+1	1+1	1+1	1+1	2+2	2+2	2+2	2+2	2+2	2+2	2+2	2+2	3+3	3+3	3+3	0+0	0+0	0+0	0+0	0+0	1+1	1+1	1+1	1+1	1+1	
		Outer	6	4	4	4	4	2	2	2	2	2	2	2	2	0	0	0	5	5	5	5	5	3	3	3	3	3	
	Fixing	Inner	-	-	-	-	-	-	-	-	-	-	-	-	-	-	-	1+1	1+1	1+1	1+1	1+1	1+1	1+1	1+1	1+1	1+1	1+1	
2	Thin	Inner						2+2	3+4	6+1	1+1	1+2	2+2	2+3	3+3	0+0	1+1	1+2	2+2	2+3	3+3	3+4	0+0	1+1	1+2	1+1	1+2	2+2	
		Outer						3	0	6	5	4	3	2	1	7	5	4	3	2	1	0	7	5	4	7	6	5	
	Thick	Inner						0+0	0+0	1+1	1+1	1+1	1+1	1+1	1+1	2+2	2+2	2+2	2+2	2+2	2+2	2+2	2+2	3+3	3+3	0+0	0+0	0+0	
		Outer						6	6	4	4	4	4	4	2	2	2	2	2	2	2	2	2	0	0	0	11	11	11
	Fixing	Inner																								1+1	1+1	1+1	
3	Thin	Inner						1+2	3+3	0+0	0+1	1+1	1+2	2+2	2+3	3+4	0+1	1+1	1+2	2+2	2+3	3+3	3+4	1+4	1+5	1+1	1+2	2+2	
		Outer						7	4	10	9	8	7	6	5	3	9	8	7	6	5	4	3	5	4	7	6	5	
	Thick	Inner						2+2	2+2	3+3	3+3	3+3	3+3	3+3	3+3	4+4	4+4	4+4	4+4	4+4	4+4	4+4	4+4	4+4	5+4	5+4	0+0	0+0	0+0
		Outer						5	5	3	3	3	3	3	3	3	1	1	1	1	1	1	1	0	0	11	11	11	
	Fixing	Inner																								1+1	1+1	1+1	
5 (TF)	Thin L	Inner																1+1	1+1	1+1	1+1	1+1	1+1	1+1	1+1	1+1	1+1	1+1	
		Outer																	8	7	6	5	4	3	2	8	7	6	5
	Thick	Inner																	0+0	0+0	0+0	0+0	0+0	1+1	1+1	1+1	1+1	1+1	
		Outer																	3	3	3	3	3	3	3	1	1	1	1
	Balancing Collar	Inner																-	-	-	-	-	-	-	-	-	-	-	
5 (TS)	Thin	Inner											0+0	0+1	1+1	1+2	2+2	3+3	0+0	0+1	1+1	1+2	2+2	3+3	0+0	0+1	1+1	1+2	2+2
		Outer											8	7	6	5	4	2	8	7	6	5	4	2	8	7	6	5	4
	Thick	Inner											0+0	0+0	0+0	0+0	0+0	1+1	1+1	1+1	1+1	1+1	1+1	1+1	2+2	2+2	2+2	2+2	2+2
		Outer											5	5	5	5	5	5	3	3	3	3	3	3	1	1	1	1	1
	Fixing Spacer	Inner																											

q – When coupling an EQ/SEQ to TS trolley with the Suspension Bar, an additional 2 thin spacers will be provided. They should be installed evenly on either side of the suspension bar.

Table 3-2 Number of Adjusting Spacers, 1/2 to 5 Ton (continued)

Beam Flange Width		(in)	6 1/16	6 7/8	7	7 1/16	7 1/4	7 7/8	8	8 7/8	8 11/16	9	9 1/8	9 7/8	10	10 1/8	10 1/4	10 3/8	10 1/2	11	11 1/8	11 1/4	11 3/8	11 5/8	11 3/4	11 13/16	11 7/8	12		
Cap (Ton)	Spacer Type	(mm)	170	175	178	180	184	200	203	215	220	229	232	250	254	257	260	264	267	279	283	286	289	295	298	300	302	305		
			181	185																										
1/2	Thin ^a	Inner	3+3	0+0	0+1	1+1	1+2	4+4	4+5	2+3	3+3	4+5	1+1	0+0	0+1	1+1	1+2	2+2	3+3	4+5	1+1	1+2	2+2	3+3	3+4	4+4	4+5	4+5	4+5	
		Outer	3	9	8	7	6	1	0	4	3	0	7	9	8	7	6	5	4	0	7	6	5	3	2	1	0	3		
	Thick	Inner	2+2	3+3	3+3	3+3	3+3	3+3	3+3	0+0	0+0	0+0	1+1	2+2	2+2	2+2	2+2	2+2	2+2	2+2	2+2	3+3	3+3	3+3	3+3	3+3	3+3	3+3	3+3	4+3
		Outer	3	1	1	1	1	1	1	7	7	7	5	3	3	3	3	3	3	3	3	1	1	1	1	1	1	1	0	
1	Thin ^a	Inner	3+3	0+0	0+1	1+1	1+2	4+4	4+5	2+3	3+3	4+5	1+1	0+0	0+1	1+1	1+2	2+2	2+3	4+5	1+1	1+2	2+2	3+3	3+4	4+4	4+5	1+5		
		Outer	3	9	8	7	6	1	0	4	3	0	7	9	8	7	6	5	4	0	7	6	5	3	2	1	0	3		
	Thick	Inner	1+1	2+2	2+2	2+2	2+2	2+2	2+2	0+0	0+0	0+0	1+1	2+2	2+2	2+2	2+2	2+2	2+2	2+2	2+2	3+3	3+3	3+3	3+3	3+3	3+3	3+3	3+3	4+3
		Outer	3	1	1	1	1	1	1	7	7	7	5	3	3	3	3	3	3	3	3	1	1	1	1	1	1	1	0	
2	Thin	Inner	3+3	0+0	0+1	1+1	1+2	0+0	0+1	2+3	3+3	4+5	1+1	0+0	0+1	1+1	1+2	2+2	2+3	4+5	1+1	1+2	2+2	3+3	3+4	4+4	4+5	1+5		
		Outer	3	9	8	7	6	9	8	4	3	0	7	9	8	7	6	5	4	0	7	6	5	3	2	1	0	3		
	Thick	Inner	0+0	1+1	1+1	1+1	1+1	2+2	2+2	2+2	2+2	2+2	3+3	4+4	4+4	4+4	4+4	4+4	4+4	4+4	4+4	5+5	5+5	5+5	5+5	5+5	5+5	5+5	6+5	
		Outer	11	9	9	9	9	7	7	7	7	7	5	3	3	3	3	3	3	3	3	1	1	1	1	1	1	0		
3	Thin	Inner	3+3	0+0	0+0	1+1	1+2	0+0	0+1	2+3	3+3	4+5	1+1	0+0	0+1	1+1	1+2	2+2	2+3	4+5	1+1	1+2	2+2	3+3	3+4	4+4	4+5	1+5		
		Outer	3	9	8	7	6	9	8	4	3	0	7	9	8	7	6	5	4	0	7	6	5	3	2	1	0	3		
	Thick	Inner	0+0	1+1	1+1	1+1	1+1	2+2	2+2	2+2	2+2	2+2	3+3	4+4	4+4	4+4	4+4	4+4	4+4	4+4	4+4	5+5	5+5	5+5	5+5	5+5	5+5	5+5	5+6	
		Outer	11	9	9	9	9	7	7	7	7	7	5	3	3	3	3	3	3	3	3	1	1	1	1	1	1	0		
Fixing	Inner	1+1	1+1	1+1	1+1	1+1	1+1	1+1	1+1	1+1	1+1	1+1	1+1	1+1	1+1	1+1	1+1	1+1	1+1	1+1	1+1	1+1	1+1	1+1	1+1	1+1	1+1	1+1		
	Outer	11	9	9	9	9	7	7	7	7	7	5	3	3	3	3	3	3	3	3	1	1	1	1	1	1	0			

q – When coupling an EQ/SEQ to TS trolley with the Suspension Bar, an additional 2 thin spacers will be provided. They should be installed evenly on either side of the suspension bar.

Table 3-2 Number of Adjusting Spacers, ½ to 5 Ton (continued)

Beam Flange Width		(in)	6 11/16	6 7/8	7	7 1/16	7 1/4	7 7/8	8	8 7/8	8 11/16	9	9 1/8	9 7/8	10	10 1/8	10 1/4	10 3/8	10 1/2	11	11 1/8	11 1/4	11 3/8	11 5/8	11 3/4	11 13/16	11 7/8	12		
Cap (Ton)	Spacer Type	(mm)	170	175	178	180	184	200	203	215	220	229	232	250	254	257	260	264	267	279	283	286	289	295	298	300	302	305		
			181	185																										
5- (TF)	Thin L	Inner	1+1	1+1	1+1	1+1	1+1	1+1	1+1	1+1	1+1	1+1	1+1	1+1	1+1	1+1	1+1	1+1	1+1	1+1	1+1	1+1	1+1	1+1	1+1	1+1	1+1	1+1	1+1	1+1
		Thin	Inner	3+3	0+4	1+4	1+1	1+2	0+0	0+1	2+3	3+3	0+1	1+1	0+0	0+1	1+1	1+2	2+2	2+3	0+1	1+1	1+2	2+2	3+3	3+4	4+4	1+4	1+5	
			Outer	2	4	3	6	5	8	7	3	2	7	6	8	7	6	5	4	3	7	6	5	4	2	1	0	3	2	
	Thick	Inner	1+1	2+1	2+1	0	0	1+1	1+1	1+1	1+1	2+2	2+2	4+4	4+4	4+4	4+4	4+4	4+4	4+4	5+5	5+5	5+5	5+5	5+5	5+5	5+5	6+5	6+5	
		Outer	1	0	0	11	11	9	9	9	9	7	7	3	3	3	3	3	3	3	1	1	1	1	1	1	1	1	0	
	Balancing Collar	Inner	-	-	-	1+1	1+1	1+1	1+1	1+1	1+1	1+1	1+1	1+1	1+1	1+1	1+1	1+1	1+1	1+1	1+1	1+1	1+1	1+1	1+1	1+1	1+1	1+1	1+1	
5- (TS)	Thin	Inner	3+3	0+4	1+4	1+1	1+2	0+0	0+1	2+3	3+3	0+1	1+1	0+0	0+1	1+1	1+2	2+2	2+3	0+1	1+1	1+2	2+2	3+3	3+4	4+4	1+4	1+5		
		Outer	2	4	3	6	5	8	7	3	2	7	6	8	7	6	5	4	3	7	6	5	4	2	1	0	3	2		
	Thick	Inner	2+2	3+2	3+2	0+0	0+0	1+1	1+1	1+1	1+1	2+2	2+2	3+3	3+3	3+3	3+3	3+3	3+3	4+4	4+4	4+4	4+4	4+4	4+4	4+4	5+4	5+4		
		Outer	1	0	0	9	9	7	7	7	7	5	5	3	3	3	3	3	3	1	1	1	1	1	1	1	1	1		
		Fixing Spacer	Inner	-	-	-	1+1	1+1	1+1	1+1	1+1	1+1	1+1	1+1	1+1	1+1	1+1	1+1	1+1	1+1	1+1	1+1	1+1	1+1	1+1	1+1	1+1	1+1	1+1	

Table 3-3 Number of Adjusting Spacer, 8 to 20 Ton

Beam Flange Width		(in)	2	2 ⁵ / ₁₆	2 ¹ / ₂	2 ⁷ / ₈	3	3 ¹ / ₄	3 ⁹ / ₁₆	3 ⁷ / ₈	3 ¹⁵ / ₁₆	4	4 ³ / ₁₆	4 ¹⁵ / ₁₆	4 ⁷ / ₁₆	4 ¹¹ / ₁₆	4 ¹ / ₆	5	5 ³ / ₁₆	5 ⁵ / ₁₆	5 ³ / ₈	5 ¹ / ₂	5 ⁵ / ₈	5 ⁷ / ₈	6	6 ¹ / ₈	6 ⁵ / ₁₆	6 ⁷ / ₁₆			
Cap (Ton)	Spacer Type	(mm)	50	58	64	73	75	82	90	98	100	102	106	110	113	119	125	127	131	135	137	140	143	149	153	155	160	163			
8	Thin	Inner																						3+4	4+4	1+1	1+2	1+2	2+3	3+3	
		Outer																							1	0	6	5	5	3	2
	Thick	Inner																							1+1	1+1	2+2	2+2	2+2	2+2	
		Outer																							6	6	4	4	4	4	4
	Fixing	Inner																						-	-	-	-	-	-	-	
10	Thin	Inner																							3+4	4+4	1+1	1+2	1+2	2+3	3+3
		Outer																							1	0	6	5	5	3	2
	Thick	Inner																							1+1	1+1	2+2	2+2	2+2	2+2	
		Outer																							6	6	4	4	4	4	4
	Fixing	Inner																						-	-	-	-	-	-	-	
15*	Thin	Inner																							0	0	0	1+0	1+1	1+2	2+2
		Outer																							13	13	10	9	8	7	6
	Thick	Inner																							0	0	0	0	0	0	
		Outer																							3	3	3	3	3	3	3
	Fixing	Inner																						-	-	-	-	-	-	-	
20*	Thin	Inner																							0	0	0	1+0	1+1	1+2	2+2
		Outer																							13	13	10	9	8	7	6
	Thick	Inner																							0	0	0	0	0	0	
		Outer																							3	3	3	3	3	3	3
	Fixing	Inner																						-	-	-	-	-	-	-	

*Note: 15 and 20 Ton models have two suspension shafts. The number of spacers above reflects the quantities per suspension shaft

Table 3-3 Number of Adjusting Spacer, 8 to 20 Ton (continued)

Beam Flange Width	(in)	6 11/16	6 7/8	7	7 1/16	7 1/4	7 7/8	8	8 7/8	8 11/16	9	9 1/8	9 7/8	10	10 1/8	10 1/4	10 3/8	10 1/2	11	11 1/8	11 1/4	11 3/8	11 5/8	11 3/4	11 9/16	11 7/8	12	
					7 7/8	7 5/16																						
Cap (Ton)	Spacer Type	(mm)	170	175	178	180 181	184 185	200	203	215	220	229	232	250	254	257	260	264	267	279	283	286	289	295	298	300	302	305
8	Thin	Inner	4+4	1+1	1+2	2+2	2+3	1+1	1+2	3+3	4+4	1+1	1+2	4+4	1+1	5+1	5+2	2+3	3+3	1+1	1+2	2+2	2+3	3+0	4+0	4+0	4+1	5+1
		Outer	0	6	5	4	3	6	5	2	0	6	5	0	6	2	1	3	2	6	5	4	3	5	4	4	3	2
	Thick	Inner	2+2	3+3	3+3	3+3	3+3	4+4	4+4	4+4	4+4	2+2	2+2	2+2	3+3	2+3	2+3	3+3	3+3	4+4	4+4	4+4	4+4	4+5	4+5	4+5	4+5	4+5
		Outer	4	2	2	2	2	0	0	0	0	5	5	5	3	4	4	3	3	1	1	1	1	0	0	0	0	0
	Fixing	Inner	-	-	-	-	-	-	-	-	-	2	2	2	2	2	2	2	2	2	2	2	2	2	2	2	2	2
			-	-	-	-	-	-	-	-	-	-	-	-	-	-	-	-	-	-	-	-	-	-	-	-	-	-
10	Thin	Inner	4+4	1+1	1+2	2+2	2+3	1+1	1+2	3+3	4+4	1+1	1+2	4+4	1+1	5+1	5+2	2+3	3+3	1+1	1+2	2+2	2+3	3+0	4+0	4+0	4+1	5+1
		Outer	0	6	5	4	3	6	5	2	0	6	5	0	6	2	1	3	2	6	5	4	3	5	4	4	3	2
	Thick	Inner	2+2	3+3	3+3	3+3	3+3	4+4	4+4	4+4	4+4	2+2	2+2	2+2	3+3	2+3	2+3	3+3	3+3	4+4	4+4	4+4	4+4	4+5	4+5	4+5	4+5	4+5
		Outer	4	2	2	2	2	0	0	0	0	5	5	5	3	4	4	3	3	1	1	1	1	0	0	0	0	0
	Fixing	Inner	-	-	-	-	-	-	-	-	-	2	2	2	2	2	2	2	2	2	2	2	2	2	2	2	2	2
			-	-	-	-	-	-	-	-	-	-	-	-	-	-	-	-	-	-	-	-	-	-	-	-	-	-
15*	Thin	Inner	3+3	0	1+0	1+1	1+2	4+0	4+1	6+2	7+3	1+1	1+2	4+4	1+1	1+2	2+2	2+3	3+3	1+1	1+2	2+2	2+3	3+4	4+4	4+0	4+1	5+1
		Outer	4	10	9	8	7	6	5	2	0	6	5	0	6	5	4	3	2	6	5	4	3	1	0	4	3	2
	Thick	Inner	0	1+1	1+1	1+1	1+1	1+2	1+2	1+2	1+2	3+3	3+3	3+3	4+4	4+4	4+4	4+4	4+4	5+5	5+5	5+5	5+5	5+5	5+5	5+6	5+6	5+6
		Outer	3	1	1	1	1	0	0	0	0	5	5	5	3	3	3	3	3	1	1	1	1	1	0	0	0	0
	Fixing	Inner	-	-	-	-	-	-	-	-	-	-	-	-	-	-	-	-	-	-	-	-	-	-	-	-	-	-
			-	-	-	-	-	-	-	-	-	-	-	-	-	-	-	-	-	-	-	-	-	-	-	-	-	-
20*	Thin	Inner	3+3	0	1+0	1+1	1+2	4+0	4+1	6+2	7+3	1+1	1+2	4+4	1+1	1+2	2+2	2+3	3+3	1+1	1+2	2+2	2+3	3+4	4+4	4+0	4+1	5+1
		Outer	4	10	9	8	7	6	5	2	0	6	5	0	6	5	4	3	2	6	5	4	3	1	0	4	3	2
	Thick	Inner	0	1+1	1+1	1+1	1+1	1+2	1+2	1+2	1+2	3+3	3+3	3+3	4+4	4+4	4+4	4+4	4+4	5+5	5+5	5+5	5+5	5+5	5+5	5+6	5+6	5+6
		Outer	3	1	1	1	1	0	0	0	0	5	5	5	3	3	3	3	3	1	1	1	1	1	0	0	0	0
	Fixing	Inner	-	-	-	-	-	-	-	-	-	-	-	-	-	-	-	-	-	-	-	-	-	-	-	-	-	-
			-	-	-	-	-	-	-	-	-	-	-	-	-	-	-	-	-	-	-	-	-	-	-	-	-	-

*Note: 15 and 20 Ton models have two suspension shafts. The number of spacers above reflects the quantities per suspension shaft

3.5 Mounting Location

3.5.1 **▲ WARNING** Prior to mounting the trolley (and hoist) ensure that the trolley beam and its supporting structure are adequate to support the trolley, hoist and its loads. If necessary consult a professional that is qualified to evaluate the adequacy of the suspension location and its supporting structure.

3.5.2 **NOTICE** See **Section 6.3** for outdoor installation considerations.

3.6 Installation of Trolley onto Beam

3.6.1 Assemble and adjust the trolley before attempting to install the trolley on the beam.

3.6.2 Preferred Method – Sliding the trolley connected with a hoist onto the traversing beam from the beam end is the most convenient and recommended method. If the trolley can be mounted from the end of the beam then: Remove the trolley end-stop from the beam and set the trolley on the beam from the end. Securely re-install the trolley end stop on the beam.

3.6.3 Optional Method for Trolleys up to 5 Ton – If the trolley cannot be mounted from the end of the beam, complete the installation as follows:

- 1) Assemble the trolley (refer to **Section 3.4**).
- 2) Remove the Shaft Stopper Pin from Suspension Shaft (See **Figure 3-35**).
- 3) Remove the outside Adjusting spacers and Reinsert the Shaft Stopper Pin. Spread the trolley side plates apart.
- 4) Lift the trolley onto the beam so that the trolley wheels of Side Plate S or G rests on the beam's flange.
- 5) Hold Side Plate S or G securely so that it does not come off the beam, then push the side plates together so that all four wheels rest on the beam's flange.
- 6) Replace the Outside Adjusting Spacers and the Shaft Stopper Pin. Insert Split Pin, Bend the Split Pin securely.

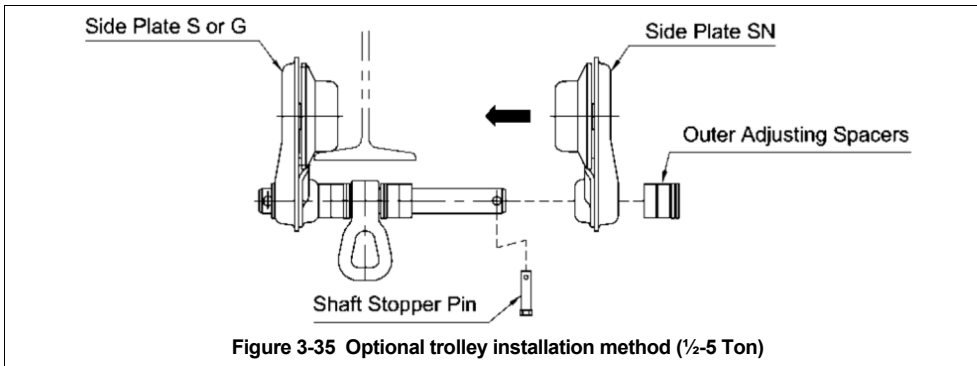

3.6.4 Optional Method for Trolleys 8 Ton to 20 Ton, coupled with Manual CB Hoist – refer to **Figure 3-36**. If the trolley cannot be mounted from the end of the beam, complete the installation as follows:

▲ WARNING ALWAYS install the trolley onto the beam before installing the hoist to the trolley. Attempting to install a pre-assembled hoist and trolley onto the beam other than onto the the beam end (per **Section 3.6.2**) is dangerous and must not be attempted.

- 1) Separate the trolley from the hoist by removing the hoist's top hook assembly from its suspension shaft.
 - For the 8-10 Ton model, the top hook assembly's suspension shaft is connected directly to the trolley side plates
 - For the 15-20 Ton model the top hook assembly's suspension shaft goes through to a pair of suspension plates that are connected to the trolley side plates by two shafts (see **Figure 3-6**). Leave the suspension plates attached to the trolley side plates.
- 2) Assemble the trolley (refer to **Section 3.4**).
- 3) Move the Shaft Stopper Pin to Hole "B" (see **Figure 3-36**).
- 4) Spread the trolley side plates apart.
- 5) Lift the trolley onto the beam so that the trolley wheels of Side Plate S or G rests on the beam's flange.
- 6) Hold Side Plate S or G securely so that it does not come off the beam then push the side plates together so that all wheels rest on the beam's flange.
- 7) Remove the Shaft Stopper Pin from Hole "B" and re-install in Hole "A" (**Figure 3-34**). Bend the Split Pin securely. Never use trolley with Shaft Stopper Pin in Hole "B". Hole "B" is ONLY used when installing the trolley on the beam.
- 8) Because two traversing units are combined in the 15 and 20 Ton trolley, ALWAYS adjust both units in the same way.

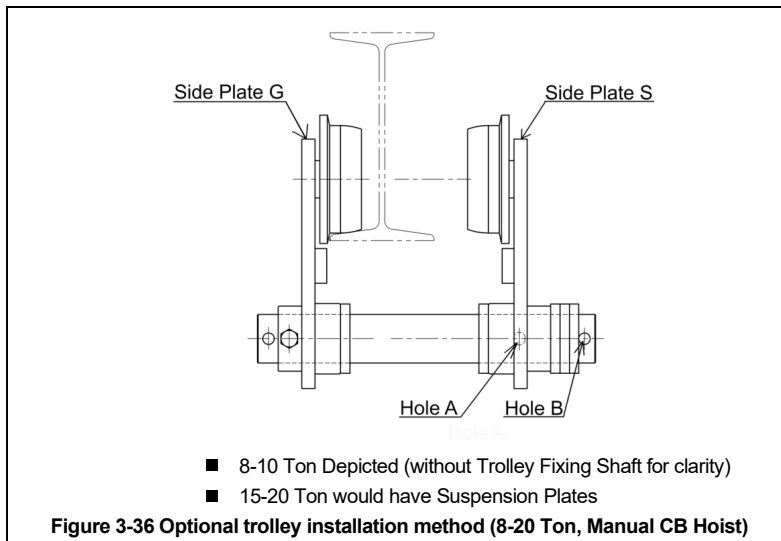

3.6.5 Optional Method for Trolleys 8 Ton to 20 Ton, coupled with Electric (N)ER/(N)ER2 hoist – refer to **Figure 3-37**.
 3.6.6 If the trolley cannot be mounted from the end of the beam, complete the installation as follows:

▲ WARNING ALWAYS install the trolley onto the beam before installing the hoist to the trolley.

Attempting to install a pre-assembled hoist and trolley onto the beam other than onto the the beam end (per **Section 3.6.2**) is dangerous and must not be attempted.

- 1) Separate the trolley from the hoist by removing the Suspension Shaft(s), Adjusting spacers, and Trolley Fixing Shaft (8 and 10 Ton only).
- 2) Reassemble the trolley without the hoist by reinstalling the suspension Shaft(s), Trolley Fixing Shaft (8 and 10 Ton only), and outside Adjusting Spacers (refer to **Section 3.4**). Place inner spacers aside until step (8).
- 3) Install the trolley on the beam by following steps (3) to (8) of **Section 3.6.4**.
- 4) Use safe and proper rigging practices to secure the trolley side plates so that they will remain firmly in place after the Suspension Shaft(s) and Trolley Fixing Shaft are removed (next step).
- 5) Remove the Suspension shaft(s), Trolley Fixing Shaft and outer Adjusting Spacers.
- 6) Move the hoist up into position between the trolley side plates and line up the trolley and hoist's Suspension Shaft holes.
- 7) Connect the hoist to the trolley by reinstalling the Suspension Shaft(s), Trolley Fixing Shaft, Adjusting Spacers, Suspension Shaft Bolts(s), and Shaft Stopper Pin(s).
- 8) Bend Split Pin(s) securely.
- 9) Ensure that:
 - Shaft Stopper Pin(s) is (are) in hole A of the Suspension Shaft(s)
 - Split Pins are installed properly.
 - Trolley is properly adjusted (refer to **Section 3.4.1**).

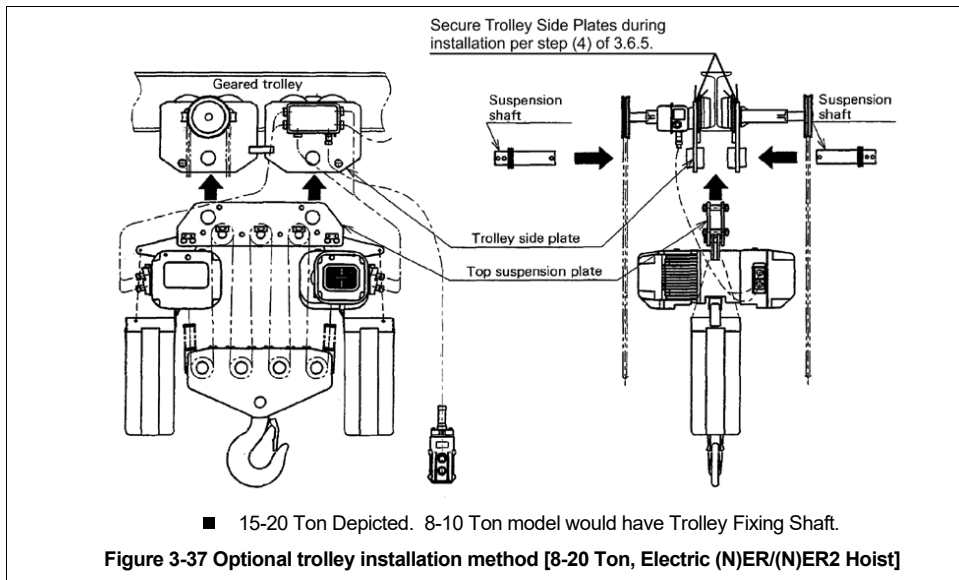

3.7 Electrical/Air Connections

- 3.7.1 This instruction applies to a Harrington Powered hoist attached to a Push or Geared Trolley. Refer to the appropriate hoist's owner's manual for the Electrical or Air connections.
- 3.7.2 **▲ DANGER** Before proceeding, ensure that the electrical supply for the hoist has been de-energized (disconnected). Lock out and tag out in accordance with ANSI Z244.1 "Personnel Protection -Lockout/Tagout of Energy Sources".
- 3.7.3 **▲ DANGER** Before proceeding, ensure that the air supply for the hoist has been de-energized (disconnected). Lock out and tag out in accordance with ANSI Z244.1 "Personnel Protection-Lockout/Tagout of Energy Sources".

Power Supply Cable/Air Supply – Installation

Cable must be installed along the beam that the trolley runs on. For curved beams a special cable suspension system will be needed, and this instruction does not apply. For straight beams install the power supply cable as follows:

- Install a guide wire system parallel to the beam. (See **Figure 3-39**)
- The guide wire should be positioned slightly outside the hoist's Cable Support Arm.
- Use the Cable Trolleys supplied with the hoist to suspend the Power Supply Cable/Air Supply Hose from the guide wire. Space the Cable Trolleys every 5 feet.
- Make sure the Guide Wire is properly tensioned and the Power Supply Cable/Air Supply Hose is not twisted or kinked.
- Festoon Cable / Guide wire should not make any contact with any component of hoist or trolley.

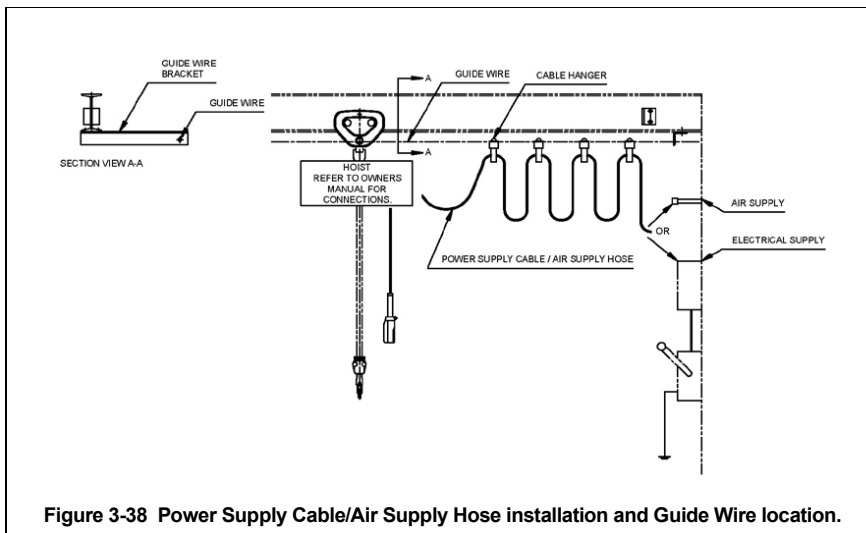

Figure 3-38 Power Supply Cable/Air Supply Hose installation and Guide Wire location.

3.8 Pre-operational Checks and Trial Operation

- 3.8.1 Refer to the trolley's Nameplate and record the Code, Lot and Serial Number in the space provided on the cover of this manual.
- 3.8.2 Refer to the hoist's owner's manual and perform all pre-operational checks for the hoist.
- 3.8.3 Perform pre-operational checks for the trolley:
- **▲ WARNING** Confirm the adequacy of the rated capacity for all slings, chains, wire ropes and all other lifting attachments before use. Inspect all load suspension members for damage prior to use and replace or repair all damaged parts.
 - Ensure that trolley is properly installed on the beam, and stops for the trolley are correctly positioned and securely installed on the beam.
 - Ensure that all nuts, bolts and split pins (cotter pins) are sufficiently fastened.
- 3.8.4 Confirm proper operation.
- Before operating read and become familiar with Section 4 - Operation.
 - Before operating ensure that the hoist (and trolley) meets the Inspection, Testing and Maintenance requirements of ANSI/ASME B30.16.
 - Before operating ensure that nothing will interfere with the full range of the trolley's (and hoist's) operation.
- 3.8.5 Proceed with trial operation to confirm proper operation.
- Operate the trolley through its full range of motion. Make sure the trolley runs smoothly and does not bind. If applicable check the power/Air supply and festoon system for proper operation
 - Perform inspections per Section 5.3, "Frequent Inspections".

4.0 Operation

4.1 Introduction

DANGER

DO **NOT** WALK UNDER A SUSPENDED LOAD

WARNING

HOIST OPERATORS SHALL BE REQUIRED TO READ THE OPERATION SECTION OF THIS MANUAL, THE WARNINGS CONTAINED IN THIS MANUAL, INSTRUCTION AND WARNING LABELS ON THE HOIST OR LIFTING SYSTEM, AND THE OPERATION SECTIONS OF ANSI/ASME B30.16 and ANSI/ASME B30.10. THE OPERATOR SHALL ALSO BE REQUIRED TO BE FAMILIAR WITH THE HOIST AND HOIST CONTROLS BEFORE BEING AUTHORIZED TO OPERATE THE HOIST OR LIFTING SYSTEM.

HOIST OPERATORS SHOULD BE TRAINED IN PROPER RIGGING PROCEDURES FOR THE ATTACHMENT OF LOADS TO THE HOIST HOOK.

HOIST OPERATORS SHOULD BE TRAINED TO BE AWARE OF POTENTIAL MALFUNCTIONS OF THE EQUIPMENT THAT REQUIRE ADJUSTMENT OR REPAIR, AND TO BE INSTRUCTED TO STOP OPERATION IF SUCH MALFUNCTIONS OCCUR, AND TO IMMEDIATELY ADVISE THEIR SUPERVISOR SO CORRECTIVE ACTION CAN BE TAKEN.

HOIST OPERATORS SHOULD HAVE NORMAL DEPTH PERCEPTION, FIELD OF VISION, REACTION TIME, MANUAL DEXTERITY, AND COORDINATION.

HOIST OPERATORS SHOULD **NOT** HAVE A HISTORY OF OR BE PRONE TO SEIZURES, LOSS OF PHYSICAL CONTROL, PHYSICAL DEFECTS, OR EMOTIONAL INSTABILITY THAT COULD RESULT IN ACTIONS OF THE OPERATOR BEING A HAZARD TO THE OPERATOR OR TO OTHERS.

HOIST OPERATORS SHOULD **NOT** OPERATE A HOIST OR LIFTING SYSTEM WHEN UNDER THE INFLUENCE OF ALCOHOL, DRUGS, OR MEDICATION.

OVERHEAD HOISTS ARE INTENDED ONLY FOR VERTICAL LIFTING SERVICE OF FREELY SUSPENDED UNGUIDED LOADS. DO **NOT** USE HOIST FOR LOADS THAT ARE NOT LIFTED VERTICALLY, LOADS THAT ARE NOT FREELY SUSPENDED, OR LOADS THAT ARE GUIDED.

NOTICE

- Read ANSI/ASME B30.16 and ANSI/ASME B30.10.
- Read the hoist manufacturer's Operating and Maintenance Instructions.
- Read all labels attached to equipment.

The operation of an overhead hoist involves more than activating the hoist's controls. Per the ANSI/ASME B30 standards, the use of an overhead hoist is subject to certain hazards that cannot be mitigated by engineered features, but only by the exercise of intelligence, care, common sense, and experience in anticipating the effects and results of activating the hoist's controls. Use this guidance in conjunction with other warnings, cautions, and notices in this manual to govern the operation and use of your overhead hoist.

4.2 Shall's and Shall Not's for Operation

WARNING

Improper operation of a hoist can create a potentially hazardous situation which, if not avoided, could result in death or serious injury, and substantial property damage. To avoid such a potentially hazardous situation **THE OPERATOR SHALL:**

- **NOT** lift more than rated load for the hoist.
- **NOT** operate unless load is centered under hoist.
- **NOT** use damaged hoist or hoist that is not working properly.
- **NOT** use hoist with twisted, kinked, damaged, or worn chain.
- **NOT** use hoist if the bottom hook is capsized (double fall hoists - see **Section 3.2**).
- **NOT** use the hoist to lift, support, or transport people.
- **NOT** lift loads over people.
- **NOT** apply load unless load chain is properly seated in the load sheave (and idle sheave for hoist with two chain falls).
- **NOT** use the hoist in such a way that could result in shock or impact loads being applied to the hoist.
- **NOT** attempt to lengthen the load chain or repair damaged load chain.
- **NOT** operate hoist when it is restricted from forming a straight line from hook to hook in the direction of loading.
- **NOT** use load chain as a sling or wrap load chain around load.
- **NOT** apply the load to the tip of the hook or to the hook latch.
- **NOT** apply load if binding prevents equal loading on all load-supporting chains.
- **NOT** operate beyond the limits of the load chain travel.
- **NOT** operate hoist with missing/damaged chain springs, cushion rubbers, stoppers or striker plates.
- **NOT** leave load supported by the hoist unattended unless specific precautions have been taken.
- **NOT** allow the chain, or hook to be used as an electrical or welding ground.
- **NOT** allow the chain, or hook to be touched by a live welding electrode.
- **NOT** remove or obscure the warnings on the hoist.
- **NOT** operate a hoist on which the safety placards or decals are missing or illegible.
- Be familiar with operating controls, procedures, and warnings.
- Make sure the unit is securely attached to a suitable support before applying load.
- Make sure load slings or other approved single attachments are properly sized, rigged, and seated in the hook saddle.
- Take up slack carefully - make sure load is balanced and load-holding action is secure before continuing.
- Make sure all persons stay clear of the supported load.
- Protect the hoist's load chain from weld splatter or other damaging contaminants.
- Report Malfunctions or unusual performances (including unusual noises) of the hoist and remove the hoist from service until the malfunction or unusual performance is resolved.
- Make sure hoist limit switches function properly.
- Warn personnel before lifting or moving a load.
- Warn personnel of an approaching load.

CAUTION

Improper operation of a hoist can create a potentially hazardous situation which, if not avoided, could result in minor or moderate injury, or property damage. To avoid such a potentially hazardous situation THE OPERATOR SHALL:

- Maintain a firm footing or be otherwise secured when operating the hoist.
- Check brake function by tensioning the hoist prior to each lift operation.
- Use hook latches. Latches are to retain slings, chains, etc. under slack conditions only.
- Make sure the hook latches are closed and not supporting any parts of the load.
- Make sure the load is free to move and will clear all obstructions.
- Avoid swinging the load or hook.
- Make sure hook travel is in the same direction as shown on controls.
- Inspect the hoist regularly, replace damaged or worn parts, and keep appropriate records of maintenance.
- Use the hoist manufacturer's recommended parts when repairing the unit.
- Lubricate load chain per hoist manufacturer's recommendations.
- **NOT** use the hoist load limiting or warning device to measure load.
- **NOT** use limit switches as routine operating stops. They are emergency devices only.
- **NOT** allow your attention to be diverted from operating the hoist.
- **NOT** allow the hoist to be subjected to sharp contact with other hoists, structures, or objects through misuse.
- **NOT** adjust or repair the hoist unless qualified to perform such adjustments or repairs.

4.3 Trolley Controls

- 4.3.1 For Plain Trolley, movement is controlled by pushing/pulling on the load or the hook of the attached hoist.
- 4.3.2 For Geared Trolley, when facing Trolley Hand Wheel:
 - Pull down on the right side of Hand Chain (Clockwise Rotation) to move the Trolley left.
 - Pull down on the left side of Hand Chain (Counterclockwise Rotation) to move the Trolley right.
- 4.3.3  **CAUTION** Avoid collisions with the end stops or other Trolleys. Damage may result.

5.0 Inspection

5.1 General

5.1.1 The inspection procedure herein is based on ANSI/ASME B30.16. The following definitions are from ANSI/ASME B30.16 and pertain to the inspection procedure below.

- **Designated Person** - a person selected or assigned as being competent to perform the specific duties to which he/she is assigned.
- **Qualified Person** - a person who, by possession of a recognized degree or certificate of professional standing, or who, by extensive knowledge, training, and experience, has successfully demonstrated the ability to solve or resolve problems relating to the subject matter and work.
- **Normal Service** - that distributed service which involves operation with randomly distributed loads within the rated load limit, or uniform loads less than 65% of rated load for not more than 25% of the time.
- **Heavy Service** - that service which involves operation within the rated load limit which exceeds normal service.
- **Severe Service** - that service which involves normal or heavy service with abnormal operating conditions.

5.2 Inspection Classification

5.2.1 Initial Inspection - prior to initial use, all new, re-installed, altered, or modified trolleys shall be inspected by a designated person to ensure compliance with the applicable provisions of this manual.

5.2.2 Inspection Classification - the inspection procedure for trolleys in regular service is divided into two general classifications based upon the intervals at which inspection should be performed. The intervals in turn are dependent upon the nature of the critical components of the trolley and the degree of their exposure to wear, deterioration, or malfunction. The two general classifications are herein designated as FREQUENT and PERIODIC, with respective intervals between inspections as defined below.

5.2.3 FREQUENT Inspection - visual examinations by the operator or other designated personnel with intervals per the following criteria:

- Normal service - monthly
- Heavy service - weekly to monthly
- Severe service - daily to weekly
- Special or infrequent service - as recommended by a qualified person before and after each occurrence.

5.2.4 PERIODIC Inspection - visual inspection by a designated person with intervals per the following criteria:

- Normal service - yearly
- Heavy service - semiannually
- Severe service – quarterly
- Special or infrequent service - as recommended by a qualified person before the first such occurrence and as directed by the qualified person for any subsequent occurrences.

5.3 Frequent Inspection

- 5.3.1 Inspections should be made on a FREQUENT basis in accordance with Table 5-1, "Frequent Inspection." Included in these FREQUENT Inspections are observations made during operation for any defects or damage that might appear between Periodic Inspections. Evaluation and resolution of the results of FREQUENT Inspections shall be made by a designated person such that the trolley is maintained in safe working condition.

Table 5-1 Frequent Inspection
All functional operating mechanisms for proper operation, proper adjustment, and unusual sounds.
Connection points between Hoist and Trolley in accordance with ANSI/ASME B30.16
Hook(s) and hook latches in accordance with ANSI/ASME B30.10
Hoist(s) attached to Trolley in accordance with ANSI/ASME B30.16

5.4 Periodic Inspection

- 5.4.1 Inspections should be made on a PERIODIC basis in accordance with Table 5-2, "Periodic Inspection." Evaluation and resolution of the results of PERIODIC Inspections shall be made by a designated person such that the trolley is maintained in safe working condition.
- 5.4.2 For inspections where load suspension parts of the trolley are disassembled, a load test per ANSI/ASME B30.16 must be performed on the trolley after it is re-assembled and prior to its return to service.

Table 5-2 Periodic Inspection
Requirements of frequent inspection.
Loose or missing bolts, nuts, pins or rivets.
Worn, cracked, or distorted parts such as pins, bearings, wheels, shafts, gears, rollers, yokes, and bumpers.
Function, instruction and warning labels for legibility and placement.

5.5 Occasionally Used Trolleys

- 5.5.1 Trolleys that are used infrequently shall be inspected as follows prior to placing in service:
- Trolley Idle More Than 1 Month, Less Than 1 Year: Inspect per FREQUENT Inspection criteria in Section 5.3.
 - Trolley Idle More Than 1 Year: Inspect per PERIODIC Inspection criteria in Section 5.4

5.6 Inspection Records

- 5.6.1 Dated inspection reports and records should be maintained at time intervals corresponding to those that apply for the hoist's PERIODIC interval per Section 5.2.4. These records should be stored where they are available to personnel involved with the inspection, maintenance, or operation of the trolley.

5.7 Inspection Methods and Criteria

5.7.1 This section covers the inspection of specific items. The list of items in this section is based on those listed in ANSI/ASME B30.16 for Frequent and Periodic Inspection. In accordance with ANSI/ASME B30.16, these inspections are not intended to involve disassembly of the trolley. Rather, disassembly for further inspection would be required if frequent or periodic inspection results so indicate. Such disassembly and further inspection should only be performed by a qualified person trained in the disassembly and re-assembly of the trolley.

Table 5-3 Trolley Inspection Methods and Criteria			
Item	Method	Criteria	Action
Functional operating mechanisms.	Visual, Auditory	Mechanisms should be properly adjusted and should not produce unusual sounds when operated.	Repair or replace as required.
Housing and Mechanical Components	Visual, Auditory, Vibration, Function	Trolley components including, suspension shafts, track wheels, track wheel axles, clevises, connection yokes, suspension bolts, shafts, gears, bearings, pins, rollers, and bumpers should be free of cracks, distortion, significant wear and corrosion. Evidence of same can be detected visually or via detection of unusual sounds or vibration during operation.	Replace.
Side Plates	Visual, Measure	Must be free of significant deformation. For 8-20 Ton trolley, the difference of dimension "A" and "B" should not exceed .0787 (2mm). See Figure 5-1	Replace.
Bolts, Nuts, Snap Rings, and Split Pins	Visual, Check with Proper Tool	Bolts, nuts, snap rings and split pins should not be loose.	Tighten or replace as required.
Track Wheel - Tread	Visual, Measure	Diameter of the inside and outside tread surface should not be less than the discard value shown in Table 5-4 .	Replace.
Track Wheel - Gear	Visual	Teeth should not be cracked, damaged, or excessively worn.	Replace.
Suspension Shaft	Visual, Measure	Suspension shaft should not be bent. Diameter should not be worn by 10% or more.	Replace.
Suspenders	Visual, Measure	Never use the suspender if its dimension of D2 – D1, d or h exceed the limits of Table 5-5 .	Replace.
Suspension Bar	Visual, Measure	The "d" and "e" dimension should not be less than 0.95 times that measured and recorded at the time of purchase (See Section 3.8). If recorded "d" and "e" values are not available for suspension bar when new, use nominal "d" and "e" values from Table 5-6 .	Replace.
Cable Hangers	Visual	Cable Hangers should not be damaged or significantly worn. Movement should be smooth and should not cause the Power Supply Cable to twist or kink.	Repair or replace as necessary.
Pendant - Labels	Visual	Labels denoting functions should be legible.	Replace.
Warning Labels	Visual	Warning Labels should be affixed to the pendant cord (see Section 1.2) and they should be legible.	Replace.

Table 5-3 Trolley Inspection Methods and Criteria			
Item	Method	Criteria	Action
Trolley Capacity Label	Visual	The label that indicates the capacity of the trolley should be legible and securely attached to the trolley.	Replace.

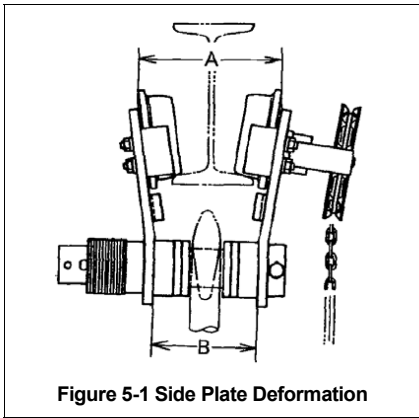
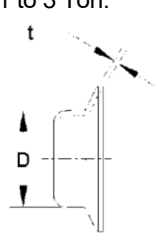
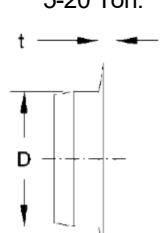
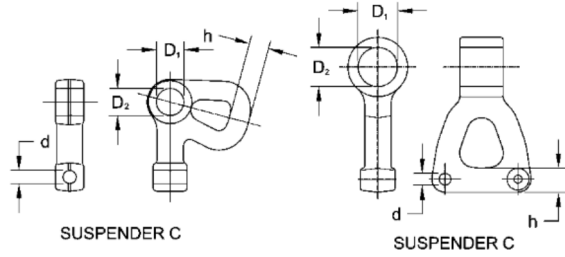

Figure 5-1 Side Plate Deformation

Table 5-4 Track Wheel Wear Dimensions					
		1 to 3 Ton:		5-20 Ton:	
					
Capacity (Ton)		"D" Dimension inch (mm)		"t" Dimension inch (mm)	
		Standard	Discard	Standard	Discard
1/2	Tapered	2.36 (60)	2.30 (58.5)	0.126 (3.2)	0.098 (2.5)
	Flat				
1	Tapered	2.80 (71)	2.74 (69.5)	0.157 (4.0)	0.130 (3.3)
	Flat				
2	Tapered	3.35 (85)	3.29 (83.5)	0.177 (4.5)	0.150 (3.8)
	Flat				
3	Tapered	3.94 (100)	3.88 (98.5)	0.197 (5.0)	0.169 (4.3)
	Flat				

5	Tapered	4.65 (118)	4.41 (112)	0.378 (9.6)	0.264 (6.7)
	Flat				
8	Tapered	6.10 (155)	5.83 (148)	0.512 (13)	0.354 (9)
10					
15					
20					

Table 5-5 Suspenders Wear Measurements



Hoist Type	Trolley Capacity	Hoist Applied Capacity	D ₁ – D ₂ Limit	d in. (mm)		h in. (mm)	
				Standard	Limit	Standard	Limit
CF or CB	1/2	1/2	0.04 (1)	0.48 (12.2)	0.512 (13.0)	0.551 (14.0)	0.492 (12.5)
	1	1/2, 1				0.709 (18.0)	0.63 (16.0)
	2	1 1/2, 2				0.866 (22.0)	0.787 (20.0)
	3	3	0.06 (1.5)	0.64 (16.2)	0.669 (17.0)	1.063 (27.0)	0.945 (24.0)
						0.945 (24.0)	0.846 (21.5)
						1.299 (33.0)	1.181 (30.0)
5	5		0.646 (16.4)				

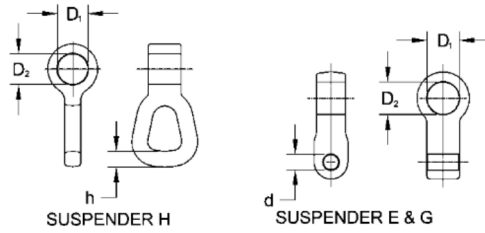

Trolley Capacity	D ₂ – D ₁ Limit	h		d	
		Standard in. (mm)	Limit in. (mm)	Standard in. (mm)	Limit in. (mm)
1/2	0.04 (1)	0.40 (10)	0.33 (8.5)	0.48 (12.2)	0.51 (13)
1		0.51 (13)	0.45 (11.5)	0.49 (12.5)	
2		0.75 (19)	0.67 (17)	0.80 (20.2)	
3	0.06 (1.5)	0.87 (22)	0.79 (20)		0.83 (21)
5		–	–	1.11 (28.2)	1.18 (30)

Table 5-5 (Continued) Suspender Wear Measurements

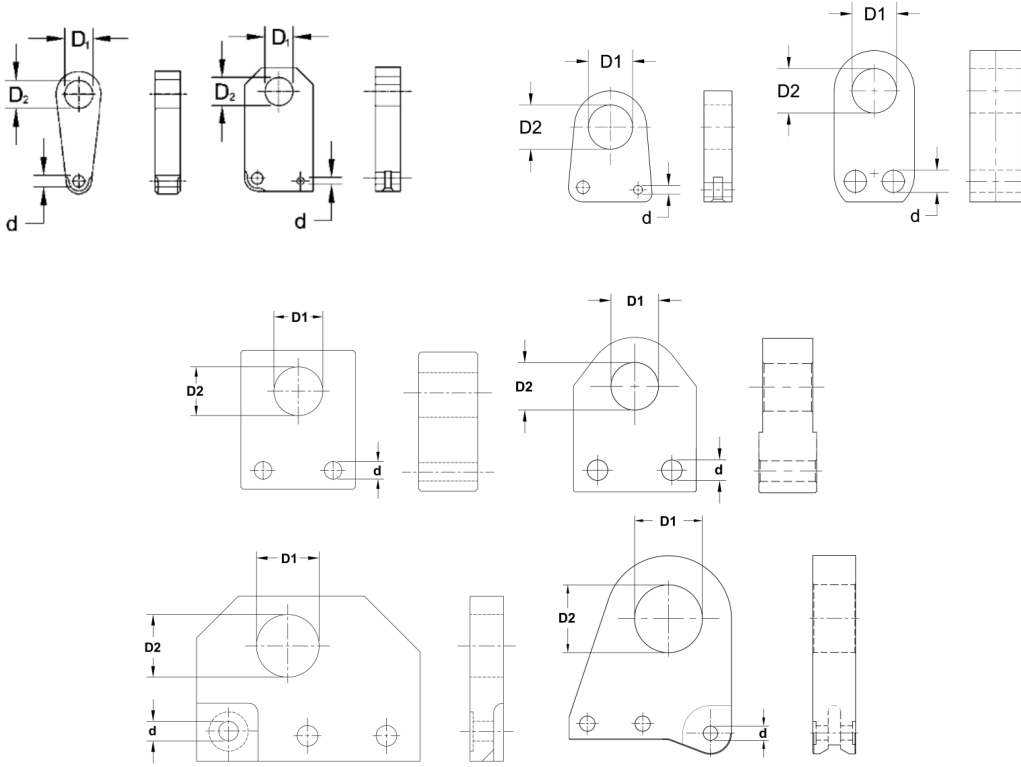

TCR/S/K/L SUSPENDERS

Trolley Capacity	Product Code	D2 – D1 Limit in. (mm)	d	
			Standard in. (mm)	Limit in. (mm)
1/4 - 1/2	TCR	0.04 (1)	0.51 (13)	0.55 (13.9)
	TCS/L	0.04 (1)	0.32 (8.1)	0.34 (8.6)
1	TCR	0.04 (1)	0.51 (13)	0.55 (13.9)
	TCS/L	0.04 (1)	0.31(7.9)	0.33 (8.4)
2	TCR	0.04 (1)	0.51 (13)	0.55 (13.9)
3	TCR	0.06 (1.5)	0.80 (20)	0.82 (20.8)
	TCK/L	0.06 (1.5)	0.63 (16)	0.65 (16.5)
6	TCR	0.08 (2)	0.55 (14)	0.57 (14.6)
	TCK/L	0.08 (2)	0.59 (15)	0.61 (15.5)
10	TCR	0.08 (2)	1.38 (35)	1.43 (36.4)

Table 5-6 EQ/SEQ Suspension Bar Dimensions

"d" and "e" Measured When New:

d: _____

e: _____

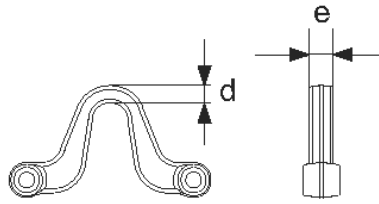

Capacity Code	"d" Dimension inch (mm)		"e" Dimension inch (mm)	
	Standard	Discard	Standard	Discard
001SD, 003SD, 005SD	0.31 (8.0)	0.30 (7.6)	0.63 (16.0)	0.60 (15.2)
010SD	0.48 (12.3)	0.46 (11.7)	0.87 (22.0)	0.82 (20.9)

6.0 Maintenance & Handling

6.1 Lubrication

- 6.1.1 Lubricate the following trolley components with NLGI (National Lubricating Grease Institute) #2 or equivalent grease.
- 6.1.2 Track Wheel Gear – Clean and re-grease the Track Wheel gears and Hand Wheel output pinion every three months (more frequently for heavier usage or severe conditions). Do not use an excessive amount of grease and avoid getting any grease on the running surfaces of the Track Wheels or the beam.
- 6.1.3 Trolley Wheel Bearings do not need to be lubricated and must be replaced if worn or damaged.
- 6.1.4 Suspension Pins, Bolts and Shafts – Grease at least twice per year for normal usage (more frequently for heavier usage or severe conditions).

6.2 Storage

- 6.2.1 The storage location should be clean and dry.

6.3 Outdoor Installation

- 6.3.1 For trolley and hoist installations that are outdoors, the trolley and hoist MUST be covered and protected from the weather when not in use.
- 6.3.2 Possibility of corrosion on components of the trolley increases for installations where salt air and high humidity are present. The trolley may require more frequent lubrication. Make frequent and regular inspections of the unit's condition and operation.

7.0 Warranty

All products sold by Harrington Hoists, Inc. are warranted to be free from defects in material and workmanship from date of shipment by Harrington for the following periods:

- 1 year – Electric and Air Powered Hoists (excluding (N)ER2 Enhanced Features Models and EQ/SEQ Models), Powered Trolleys, Powered Tiger Track Jibs and Gantries, Crane Components, Below the Hook Devices, Spare / Replacement Parts**
- 2 years – Manual Hoists & Trolleys, Beam Clamps**
- 3 years – (N)ER2 Enhanced Features Hoists, EQ/SEQ Hoists, and RY Hoists**
- 5 years – Manual Tiger Track Jibs and Gantries, TNER, EQ/SEQ, and RY Hoist Motor Brakes**
- 10 years – (N)ER2 “The Guardian” Smart Brake**

The product must be used in accordance with manufacturer’s recommendations and must not have been subject to abuse, lack of maintenance, misuse, negligence, or unauthorized repairs or alterations.

Should any defect in material or workmanship occur during the above time period in any product, as determined by Harrington Hoist’s inspection of the product, Harrington Hoists, Inc. agrees, at its discretion, either to replace (not including installation) or repair the part or product free of charge and deliver said item F.O.B. Harrington Hoists, Inc. place of business to customer.

Customer must obtain a Return Goods Authorization as directed by Harrington or Harrington’s published repair center prior to shipping product for warranty evaluation. An explanation of the complaint must accompany the product. Product must be returned freight prepaid. Upon repair, the product will be covered for the remainder of the original warranty period. Replacement parts installed after the original warranty period will only be eligible for replacement (not including installation) for a period of one year from the installation date. If it is determined there is no defect, or that the defect resulted from causes not within the scope of Harrington’s warranty, the customer will be responsible for the costs of returning the product.

Harrington Hoists, Inc. disclaims any and all other warranties of any kind expressed or implied as to the product’s merchantability or fitness for a particular application. Harrington will not be liable for death, injuries to persons or property or for incidental, contingent, special or consequential damages, loss or expense arising in connection with the use or inability whatever, regardless of whether damage, loss or expense results from any act or failure to act by Harrington, whether negligent or willful, or from any other reason.

8.0 1/2 to 20 Ton Parts List

When ordering Parts, please provide the Hoist code number, lot number and serial number located on the Hoist nameplate (see fig. below).

Reminder: Per sections 1.1 and 3.5.1 to aid in ordering Parts and Product Support, record the Hoist code number, lot number and serial number in the space provided on the cover of this manual.

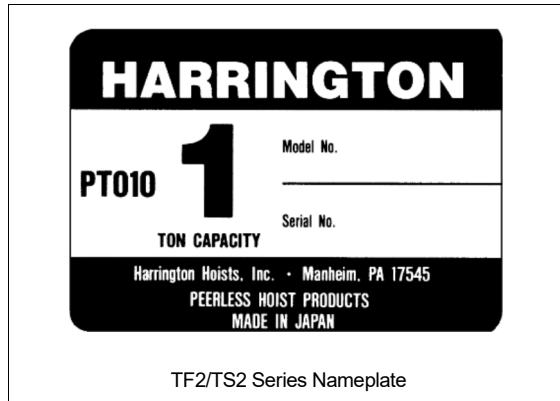

The parts list is arranged into the following sections:

Section 1/2 to 5 Ton	Page
8.1 TF2 Push Trolley Parts – 1/8 to 5 Ton	64
8.2 TF2 Geared Trolley Parts – 1/8 to 5 Ton.....	66
8.3 TS2 Push Trolley Parts – 1/8 to 5 Ton	68
8.4 TS2 Geared Trolley Parts – 1/8 to 5 Ton	70
Section 8 to 20 Ton	
8.5 TF/TS Push/Geared Trolley Parts for CB Hoist – 8 to 10 Ton	72
8.6 TF/TS Push/Geared Trolley Parts for ER2 Hoist – 8 to 10 Ton	74
8.7 TF/TS Geared Trolley Parts for CB Hoist – 15 to 20 Ton	76
8.8 TF/TS Geared Trolley Parts for ER2 Hoist – 15 to 20 Ton	80

In the column "Parts Per Trolley" a designator is used for parts that apply only to a particular model or option.

Refer to Section 2 for TF2/TS2 Trolley model numbers and additional descriptions.

The designators are:

- Push = Push TF or TS model only
- Geared = Geared TF or TS model only
- Std. = Standard Flange Range
- Wide = Optional Wide Flange Range
- TS = TS model only

8.1 TF2 Push Trolley Parts – 1/8 to 5 Ton

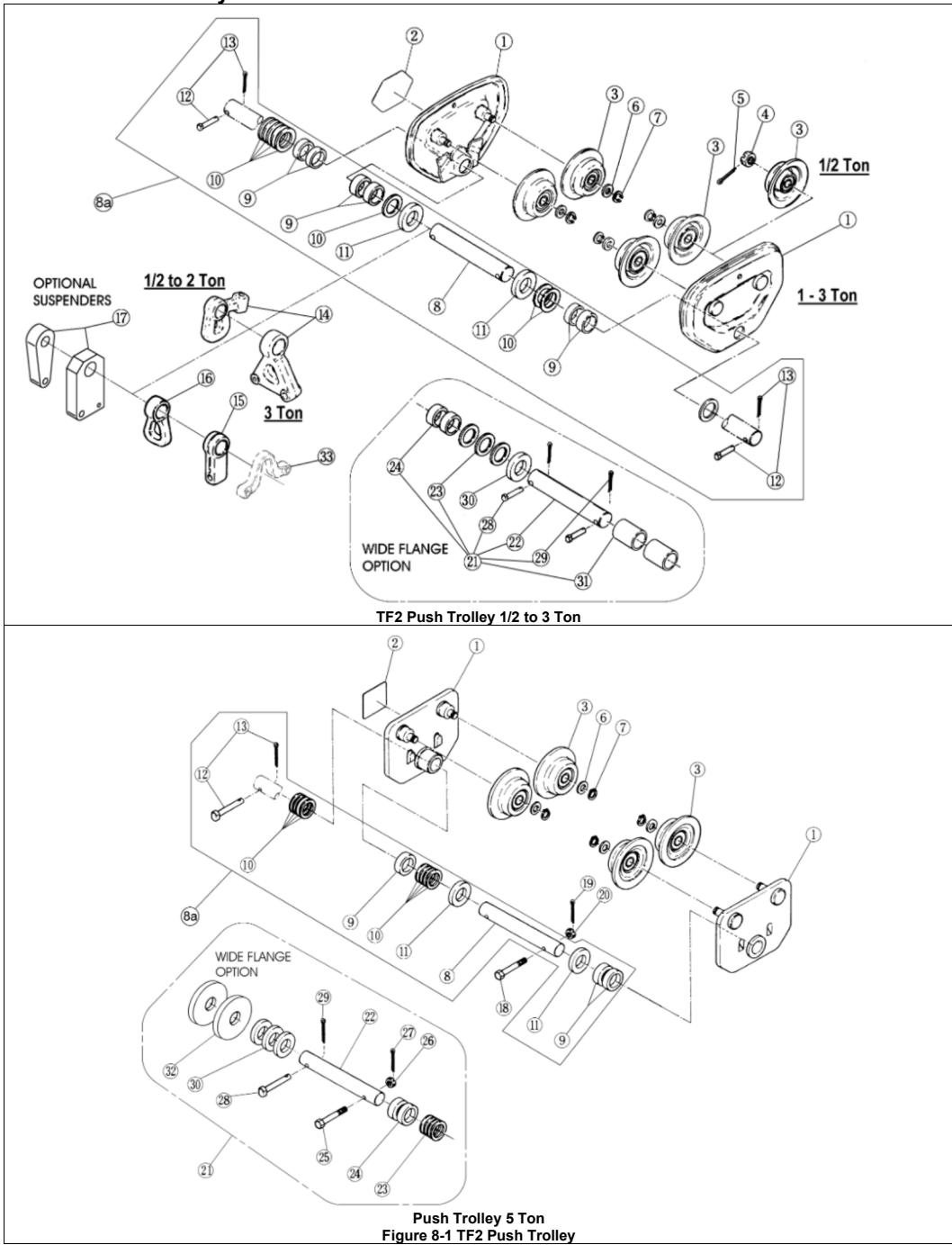

Push Trolley 5 Ton
Figure 8-1 TF2 Push Trolley

8.2 TF2 Geared Trolley Parts – 1/8 to 5 Ton

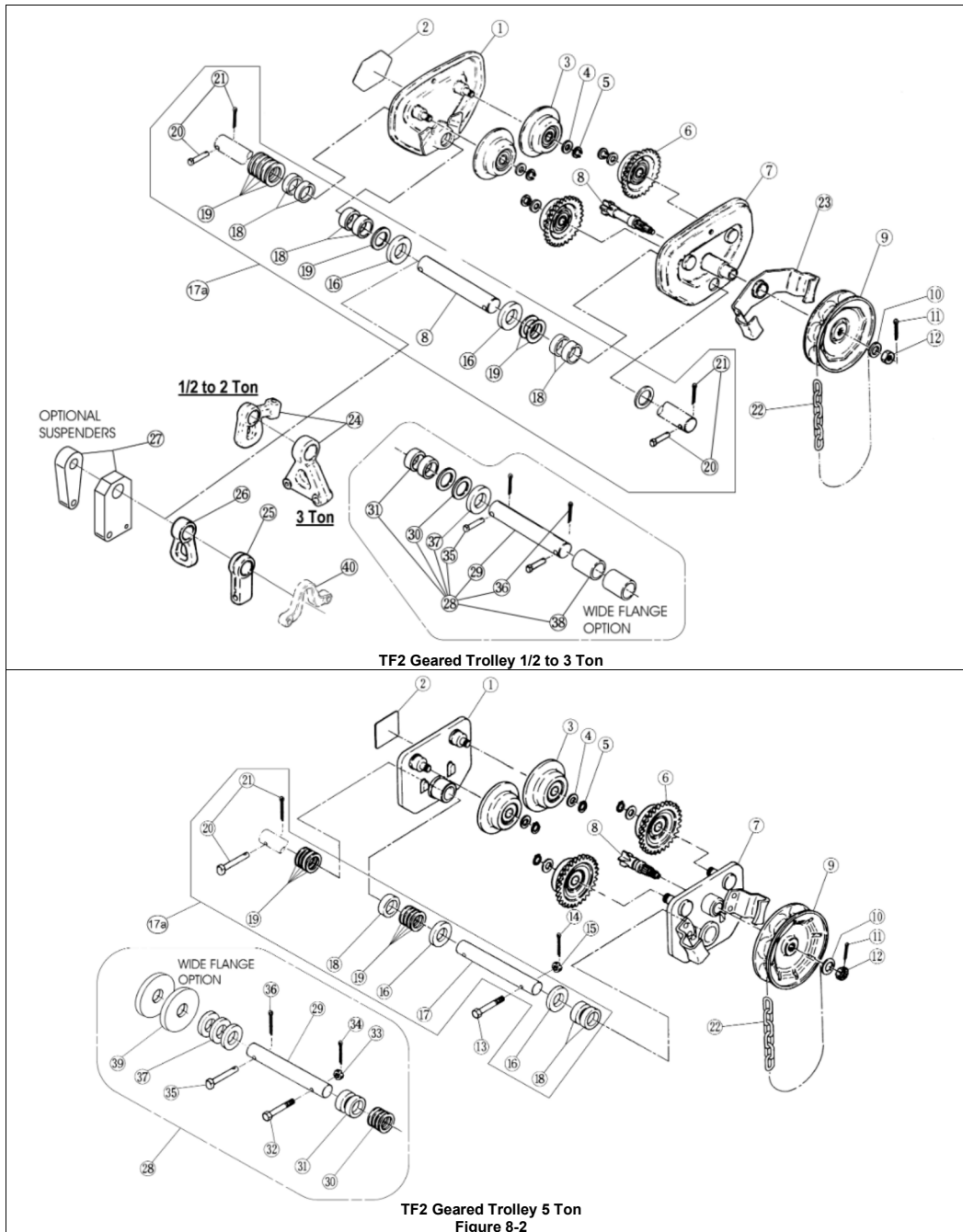

8.2 TF2 Geared Trolley Parts – 1/8 to 5 Ton

Figure No.	Part Name	Parts Per Trolley	1 Ton	2 Ton	3 Ton	5 Ton
1	Sideplate S Assembly	1	T6G5112010	T6G5112020	T6G5112030	T3P110050
2	Name plate B	1	T6G800010G	T6G800020G	T6G800030G	T3G800050
3	Track wheel S Assembly	2	T6G5102010	T6G5102020	T6G5102030	T3P1102050
4	Track wheel washer	4	MS104010	MS104020	MS104030	MS104050
5	Snap ring	4	9047115	9047120	9047125	9047135
6	Track wheel G Assembly	2	T6G5101010	T6G5101020	T6G5101030	T3G1101050
7	Sideplate G Assembly	1	T6G5111010	T6G5111020	T6G5111030	T3G5111050
8	Pinion	1	T7GC121010	T7GB121020		T3G121020
9	Hand wheel	1	T6G123010			T3G123010
10	Washer	1	9012515			
11	Split pin	1	9009423			
12	Lever nut	1	L4082090			T3G259010
13	Bolt Assembly	1				T3P153050
14	Split pin	1				9009423
15	Slotted nut	1				T3P154050
16	Thin Spacer L (qty)	X	T7GA010-9303 (2 ⁿ)			T6G119050(2)
17a	Suspension shaft assembly Standard	1	T7G1115010	T7G1115020	T7G1115030	T6G1115050
17	Suspension shaft	1	T7G115010	T7G115020	T7G115030	T6G115050
18	Thick spacer (qty)	X	T7G116010(6)	T7G116020(6)	T7G116030(9)	MSF116030(3)
19	Thin spacer (qty)	X	T7G117010(9)	T7G117020(8)	T7G117030(11)	T6G120050(8)
20	Shaft stopper pin	2	T6G156010	T6G156020	MS164020	MS164030
21	Split pin	2	9009423	9009432		
22	Hand chain	1	HCCF005			
23	Hand chain guide Assembly	1	T6G5121010			
24	Suspender C	1	T7GC004010	T7GC004020	T7GC004030 (T7GC004025)**	
25	Suspender E	1	T7GB004010	T7GB004020	T7GB004030	
26	Suspender H	1	T6G019010	T6G019020	T6G019030	
27	TCR Suspender	1	60403 (1 Fall Chain)	6040403	TF26K531030S	
	TCS/L Suspender		6040201(2 Fall Chain)			
28	Suspension Shaft Assembly Extended	1	T7GD136010 {5.01 to 8.00'}	T7GD181020 {6.03 to 12.00'}	T7GD181030 {6.03 to 12.00'}	T6GD181050 {7.03 to 12.00'}
			T7GD181010 {8.01 to 12.00'}			
29	Suspension Shaft	1	T7GA0109136 {5.01 to 8.00'}	T7GA0209181 {6.03 to 12.00'}	T7GA0309181 {6.03 to 12.00'}	T6GA0509181 {7.03 to 12.00'}
			T7GA0109181 {8.01 to 12.00'}			
30	Thin Spacer	X	T7G117010 (10)	T7G117020 (10)	T7G117030 (10)	T6G120050 (8)
31	Thick Spacer	X	T7G116010 {5.01 to 8.00'-(5) {8.01 to 12.00'-(7)}	T7G116020 (11)	T7G116030 (11)	MSF116030 (11)
32	Bolt	1				T3P153050
33	Nut	1				T3P154050
34	Split Pin	1				9009423
35	Shaft Stopper Pin	*2	T6G156010	T6G156020	MS164020	MS164030
36	Split Pin	*2	9009423	9009432		
37	Thin Spacer L (qty)	X	T7GA010-9303 (2 ⁿ)			T6G119050
38	Fixing Spacer	2	T7GA0109137 {5.01 to 8.00'}	T7GA0209182	T7GA0309182	
			T7GA0109182 {8.01 to 12.00'}			
39	Balancing Collar	2				T3GA0509137
40	EQ/SEQ Suspension Bar (001-005 hoist)	1	EQ1C19001			
	EQ/SEQ Suspension Bar (010 hoist)		EQ1D19001			

* Quantity is 1 for 5 Ton.

** Suspender for use with model CB025, 2 ½ Ton.

q – These spacers are only provided with EQ/SEQ hoists with suspension bar

8.3 TS2 Push Trolley Parts – 1/8 to 5 Ton

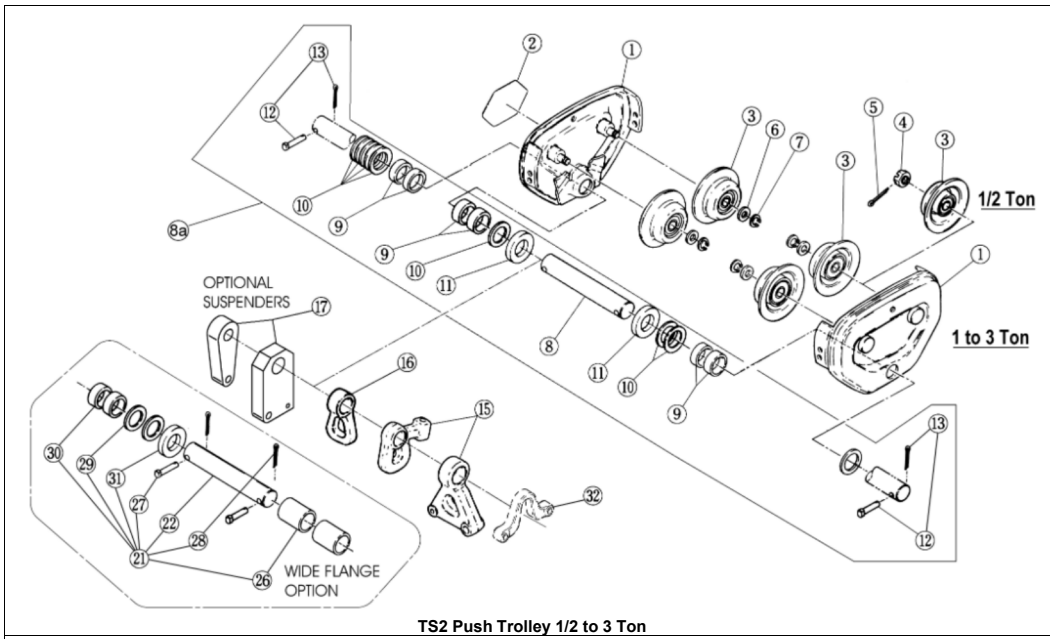

TS2 Push Trolley 1/2 to 3 Ton

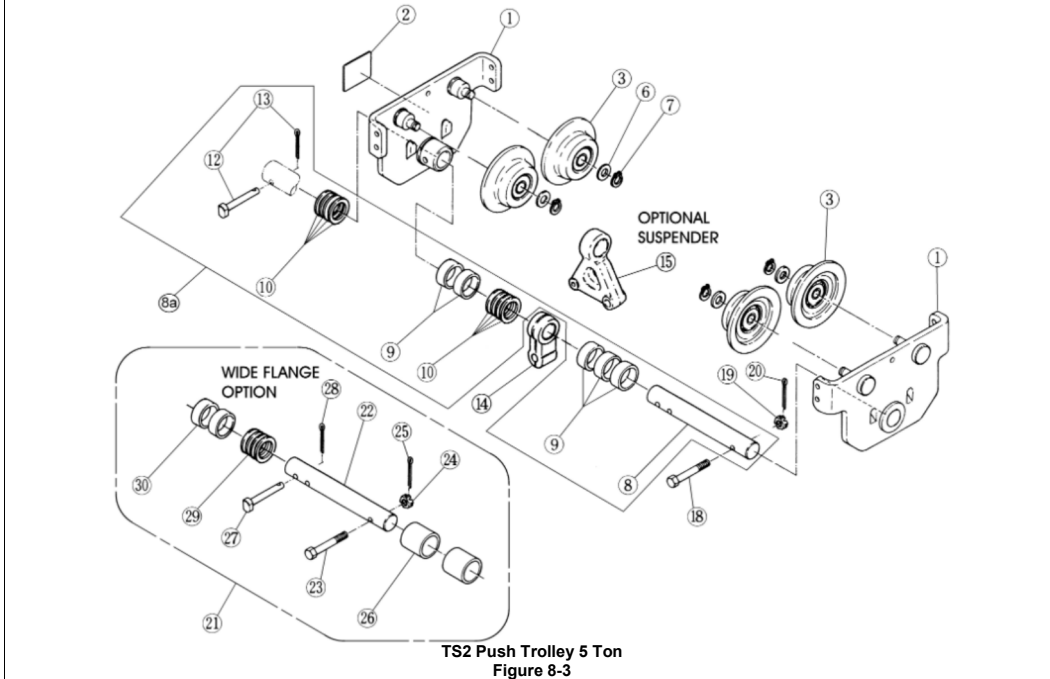

TS2 Push Trolley 5 Ton
Figure 8-3

8.3 TS2 Push Trolley Parts – 1/8 to 5 Ton

Figure No.	Part Name	Parts Per Trolley	1/2 Ton	1 Ton	2 Ton	3 Ton	5 Ton
1	Side Plate S Assembly	2	T7PA0055112	T7GA0105112	T7GA0205112	T7GA0305112	T5GA0505112
2	Name plate B	1	T6G800005P	T6G800010P	T6G800020P	T6G800030P	T3P800050
3	Track wheel S Assembly	4	T6G5102005	T6G5102010	T6G5102020	T6G5102030	T3P1102050
4	Slotted nut	4	L3183008				
5	Split pin	4	9009413				
6	Track wheel washer	4		MS104010	MS104020	MS104030	MS104050
7	Snap ring	4		9047115	9047120	9047125	9047135
8a	Suspension shaft assembly Standard	1	T7G1115005	T7G1115010	T7G1115020	T7G1115030	T7G1115050
8	Suspension shaft	1	T7G115005	T7G115010	T7G115020	T7G115030	T7GA0509115
9	Thick spacer (qty)	X	T7G116005(4)	T7G116010(6)	T7G116020(6)	T7G116030(9)	MSF116050(5)
10	Thin spacer (qty)	X	T7G117005(10)	T7G117010(9)	T7G117020(8)	T7G117030(11)	MSF117050(8)
11	Thin spacer L (qty)	X	T7PA005-9301(2 ^a)	T7GA010-9303 (2 ^a)			
12	Shaft stopper pin	2	T6G156005	T6G156010	T6G156020	MS164020	MS164050
13	Split pin	2	9009423		9009432		
14	Suspender E & G	1	T7GB004005	T7GB004010	T7GB004020	T7GB004030	M7S004050
15	Suspender C	1	T7GC004005	T7GC004010	T7GC004020	T7GC004030	M3004050
16	Suspender H	1	T6G019005	T6G019010	T6G019020	T6G019030	
17	TCR Suspender	1	6040204	60403 (1 Fall Chain) 6040201 (2 Fall Chain)	6040403	TF26K531030S	
	TCK/L Suspender				TCK30DKJ110	TCK60DKJ110 (6 Ton)	
	TCS/L Suspender		60396	70271			
18	Bolt Assembly	1					T3P153050
19	Split pin	1					9009423
20	Slotted nut	1					T3P154050
21	Suspension Shaft Assembly Extended	1	T7PD136005 {4.01 to 8.00"} T7PD181005 {8.01 to 12.00"} T7PA0059136 {4.01 to 8.00"} T7PA0059181 {8.01 to 12.00"} T7GA0109136 {5.01 to 8.00"} T7GA0109181 {8.01 to 12.00"} T7GD136010 {5.01 to 8.00"} T7GD181010 {8.01 to 12.00"} T7GD181020 {6.03 to 12.00"} T7GD181030 {6.03 to 12.00"} T7GA0209181 {6.03 to 12.00"} T7GA0309181 {6.03 to 12.00"} T7GA0509181 {7.03 to 12.00"} T3P153050 T3P154050 9009423				
	Suspension Shaft		1				
23	Bolt	1					T3P153050
24	Nut	1					T3P154050
25	Split Pin	1					9009423
26	Fixing Spacer	2	T7PA0059137 {4.01 to 8.00"} T7PA0059182 {8.01 to 12.00"} T7GA0109137 {5.01 to 8.00"} T7GA0109182 {8.01 to 12.00"} T7GA0209182 T7GA0309182 T7GA0509182				
27	Shaft Stopper Pin	*2	T6G156005	T6G156010	T6G156020	MS164020	MS164050
28	Split Pin	*2	9009423		9009432		
29	Thin Spacer	X	T7G117005 (10)	T7G117010 (10)	T7G117020 (10)	T7G117030 (10)	MSF117050 (8)
30	Thick Spacer	X	T7G116005 (7)	T7G116010 {5.01 to 8.00"}-(5) {8.01 to 12.00"}-(7)	T7G116020 (11)	T7G116030 (11)	MSF116050 (11)
31	Thin Spacer L (qty)	X	T7PA005-9301(2 ^a)	T7GA010-9303 (2 ^a)			
32	EQ/SEQ Suspension Bar	1	EQ1CI9001	EQ1DI9001			

* Quantity is 1 for 5 Ton.

q – These spacers are only provided with EQ/SEQ hoists with suspension bar

8.4 TS2 Geared Trolley Parts – 1/8 to 5 Ton

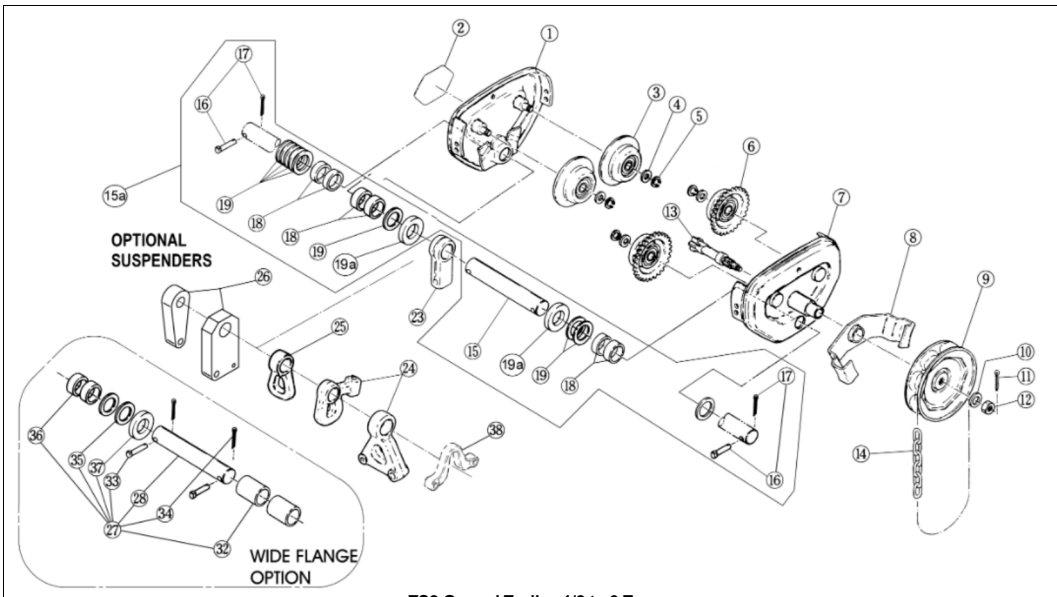

TS2 Geared Trolley 1/2 to 3 Ton

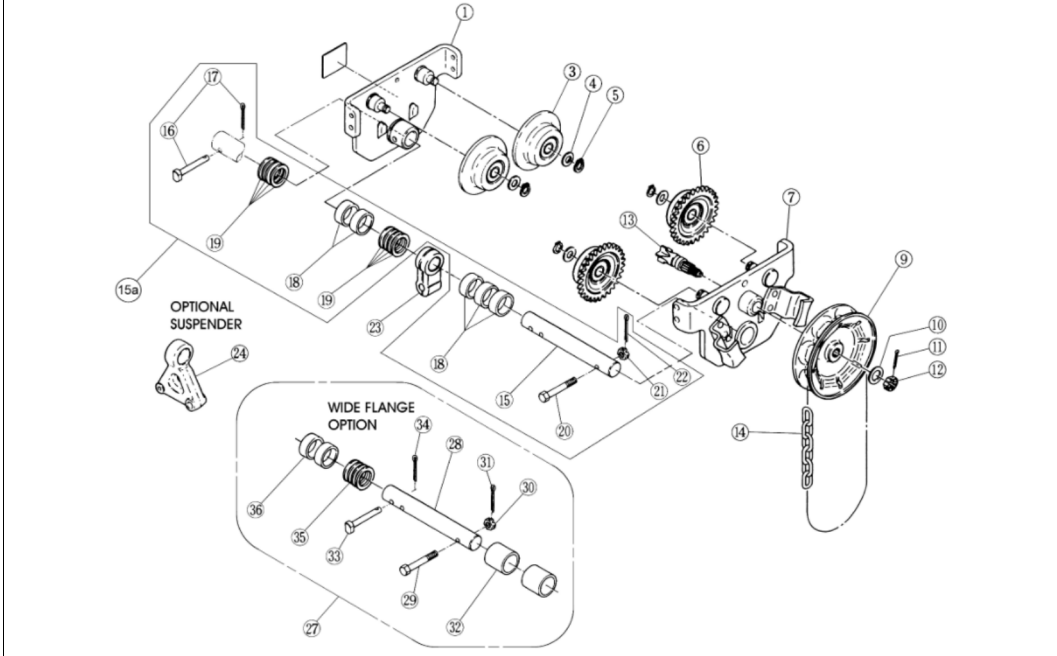

TS2 Geared Trolley 5 Ton
Figure 8-4

8.4 TS2 Geared Trolley Parts – 1/8 to 5 Ton

Figure No.	Part Name	Parts Per Trolley	1 Ton	2 Ton	3 Ton	5 Ton
1	Sideplate S Assembly	1	T7GA0105112	T7GA0205112	T7GA0305112	T5GA0505112
2	Name plate B	1	T6G800010G	T6G800020G	T6G800030G	T3G800050
3	Track wheel S Assembly	2	T6G5102010	T6G5102020	T6G5102030	T3P1102050
4	Track wheel washer	4	MS104010	MS104020	MS104030	MS104050
5	Snap ring	4	9047115	9047120	9047125	9047135
6	Track wheel G Assembly	2	T6G5101010	T6G5101020	T6G5101030	T3G1101050
7	Sideplate G Assembly	1	T7GB0105111	T7GA0205111	T7GA0305111	T5GA0505111
8	Hand chain guide Assembly	1	T6G5121010			
9	Hand wheel	1	T6G123010			T7GA0509123
10	Washer	1	9012515			
11	Split pin	1	9009423			
12	Lever nut	1	L4082090			T3P154050
13	Pinion	1	T7GC121010	T7GB121020		T4GB01091211
14	Hand chain	1	HCCF005			
15a	Suspension shaft assembly Standard	1	T7G1115010	T7G1115020	T7G1115030	T7G1115050
15	Suspension shaft	1	T7G115010	T7G115020	T7G115030	T7GA0509115
16	Shaft stopper pin	2	T6G156010	T6G156020	MS164020	MS164030
17	Split pin	2	9009423			
18	Thick spacer (qty)	X	T7G116010(6)	T7G116020(6)	T7G116030(9)	MSF116050(5)
19	Thin spacer (qty)	X	T7G117010(9)	T7G117020(8)	T7G117030(11)	MSF117050(8)
19a	Thin Spacer L (qty)	X	T7GA010-9303 (2 ^o)			
20	Bolt Assembly	1				T3P153050
21	Slotted nut	1				T3P154050
22	Split pin	1				9009423
23	Suspender E	1	T7GB004010	T7GB004020	T7GB004030	M7S004050
24	Suspender C	1	T7GC004010	T7GC004020	T7GC004030	M3004050
25	Suspender H	1	T6G019010	T6G019020	T6G019030	
26	TCR Suspender	1	6040201 (1 Fall Chain) 60403 (2 Fall Chain)	6040403	TF26K531030S	
	TCK/L Suspender			TCK30DKJ110	TCK60DKJ110 (6 Ton)	
	TCS/L Suspender		70271			
27	Suspension Shaft Assembly Extended	1	T7GD136010 {5.01 to 8.00"} T7GD181010 {6.03 to 12.00"} T7GD181010 {8.01 to 12.00"} T7GA0109136 {5.01 to 8.00"} T7GA0209181 {6.03 to 12.00"} T7GA0309181 {6.03 to 12.00"} T7GA0509181 {7.03 to 12.00"} T7GA0109181 {8.01 to 12.00"} T7GA0109137 {5.01 to 8.00"} T7GA0109182 {6.03 to 12.00"} T7GA0109182 {8.01 to 12.00"} T6G156010 9009423	T7GD181020 {6.03 to 12.00"} T7GD181030 {6.03 to 12.00"} T7GA0209181 {6.03 to 12.00"} T7GA0309181 {6.03 to 12.00"} T7GA0209182 T7GA0309182	T7GD181030 {6.03 to 12.00"} T7GA0309181 {6.03 to 12.00"} T7GA0309182 T7GA0309182	T7GD181050 {7.03 to 12.00"} T7GA0509181 {7.03 to 12.00"} T7GA0509182
			28	Suspension Shaft	1	
29	Bolt	1				T3P153050
30	Nut	1				T3P154050
31	Split Pin	1				9009423
32	Fixing Spacer	2	T7GA0109137 {5.01 to 8.00"} T7GA0109182 {6.03 to 12.00"} T7GA0109182 {8.01 to 12.00"} T6G156010 9009423	T7GA0209182	T7GA0309182	T7GA0509182
33	Shaft Stopper pin	*2	T6G156010	T6G156020	MS164020	MS164050
34	Split Pin	*2	9009423			
35	Thin Spacer	X	T7G117010 (10)	T7G117020 (10)	T7G117030 (10)	MSF117050 (8)
36	Thick Spacer	X	T7G116010 {5.01 to 8.00"}-(5) {8.01 to 12.00"}-(7)	T7G116020 (11)	T7G116030 (11)	MSF116050 (11)
37	Thin Spacer L (qty)	X	T7GA010-9303 (2 ^o)			
38	EQ/SEQ Suspension Bar (001-005 hoist)	1	EQ1C19001			
	EQ/SEQ Suspension Bar (010 hoist)		EQ1D19001			

* Quantity is 1 for 5 Ton.

q – These spacers are only provided with EQ/SEQ hoists with suspension bar

8.5 TF/TS Push/Geared Trolley Parts for CB Hoist – 8 to 10 Ton

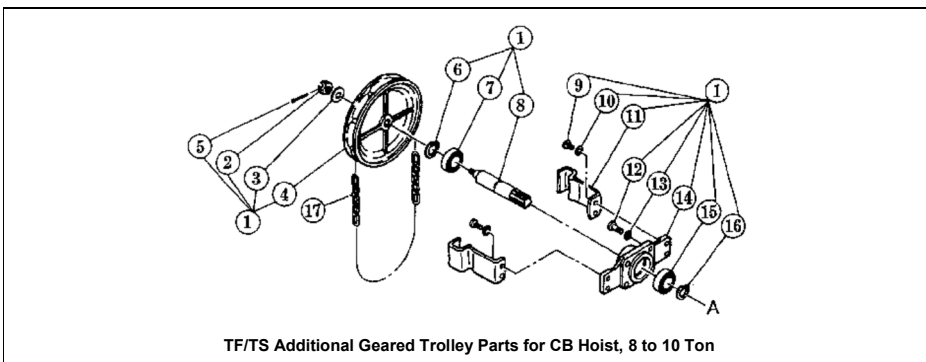
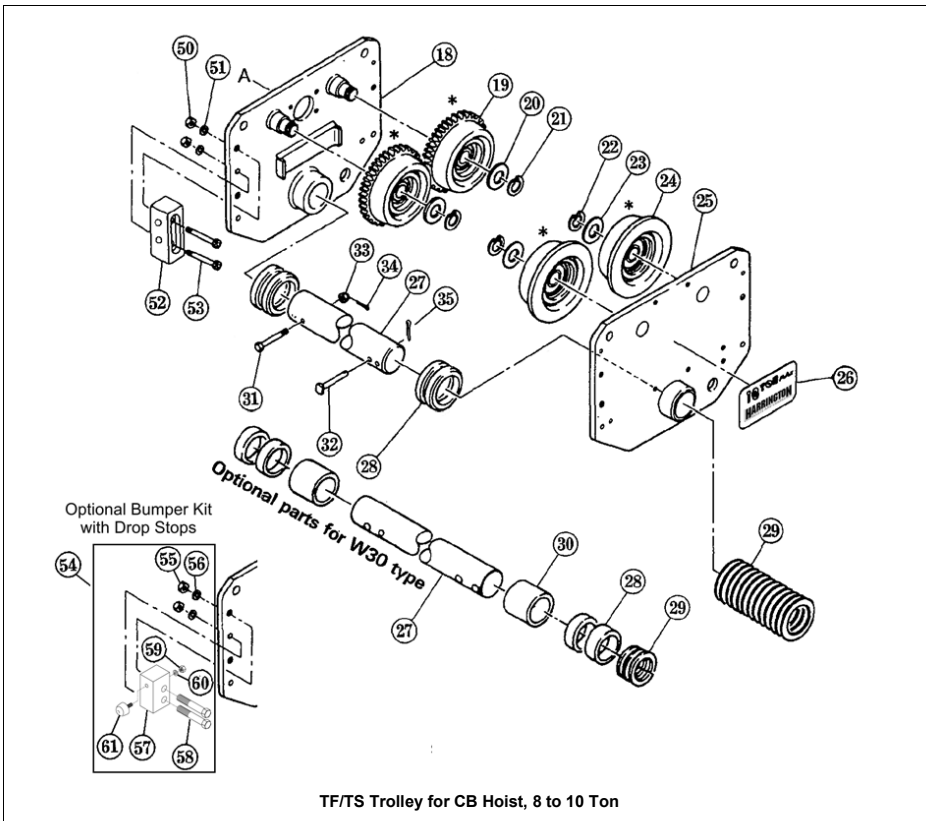

8.5 TF/TS Push/Gearred Trolley Parts for CB Hoist – 8 to 10 Ton

Figure No.	Part Name	Parts Per Trolley		8 Ton		10 Ton	
1	Hand wheel Assembly	Geared	1	T3G123AM075			
2	Slotted nut		1	T3P154050			
3	Washer		1	9012515			
4	Hand wheel		1	T3G123075			
5	Split Pin		1	9009423			
6	Snap ring		2	9047130			
7	Ball bearing		2	9000506			
8	Pinion		1	T3G127100			
9	Socket bolt		4	9091272			
10	Spring washer		4	9012711			
11	Hand chain guide		2	T3G125075			
12	Socket bolt		4	9091295			
13	Spring washer		4	9012712			
14	Pinion holder		1	T3G128100			
15	Ball bearing		2	9000506			
16	Snap ring		2	9047130			
17	Hand chain	1	HCCF005				
18	Side plate G Assembly	1	T3G5111075				
19	Track wheel G Assembly	2	T3G1101075				
20	Washer	4	MS104075				
21	Snap ring	4	9047140				
22	Snap ring	4	9047140				
23	Washer	4	MS104075				
24	Track wheel S assembly	2	T3G1102075				
25	Side plate S assembly	1	T3G5110075				
26	Name plate B	Push	1	T3P800080	T3P800100		
		Geared		T3G800080	T3G801100		
27	Suspension Shaft	Std.	1	MS115075			
		Wide		MSF181075			
28	Thick spacer*	8	MS117075				
29	Thin spacer*	Std.	8	MS116075			
		Wide	9				
30	Fixing spacer	Wide	2	M6SE100S9182			
31	Bolt	1	MS161100				
32	Shaft stopper pin	1	MS164075				
33	Slotted nut	1	T3G154075				
34	Split pin	1	9009436				
35	Split pin	1	9009436				
50	Nut	TS (Not compatibl e with bumpers)	8	9093439			
51	Spring washer		8	9012715			
52	Drop Stop		4	T5AB0759141			
53	Socket bolt	8	90912156				
54	Bumper Kit	Optional for TF or TS	4	6078501			
55	Nut		8	9093439			
56	Spring washer		8	9012715			
57	Drop Stop		4	60818			
58	Socket bolt		8	9093196			
59	Nut		4	9093424			
60	Spring washer		4	9012711			
61	Bumper	4	MR1FS9631				

*See owner's manual for placement of thick and thin spacers.

8.6 TF/TS Push/Geared Trolley Parts for ER2 Hoist – 8 to 10 Ton

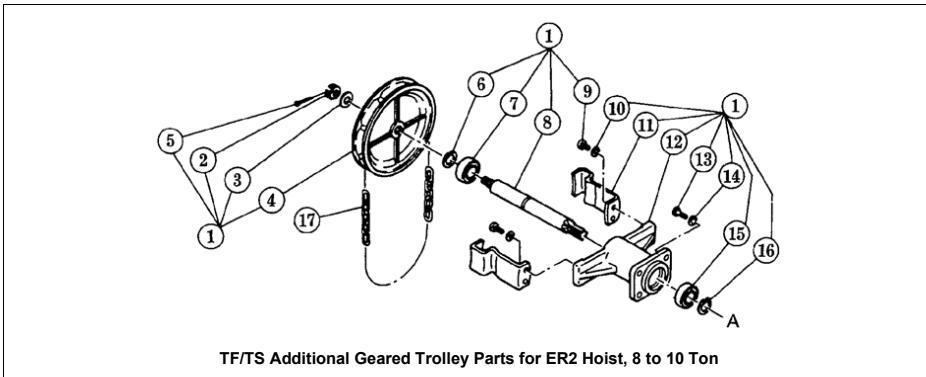
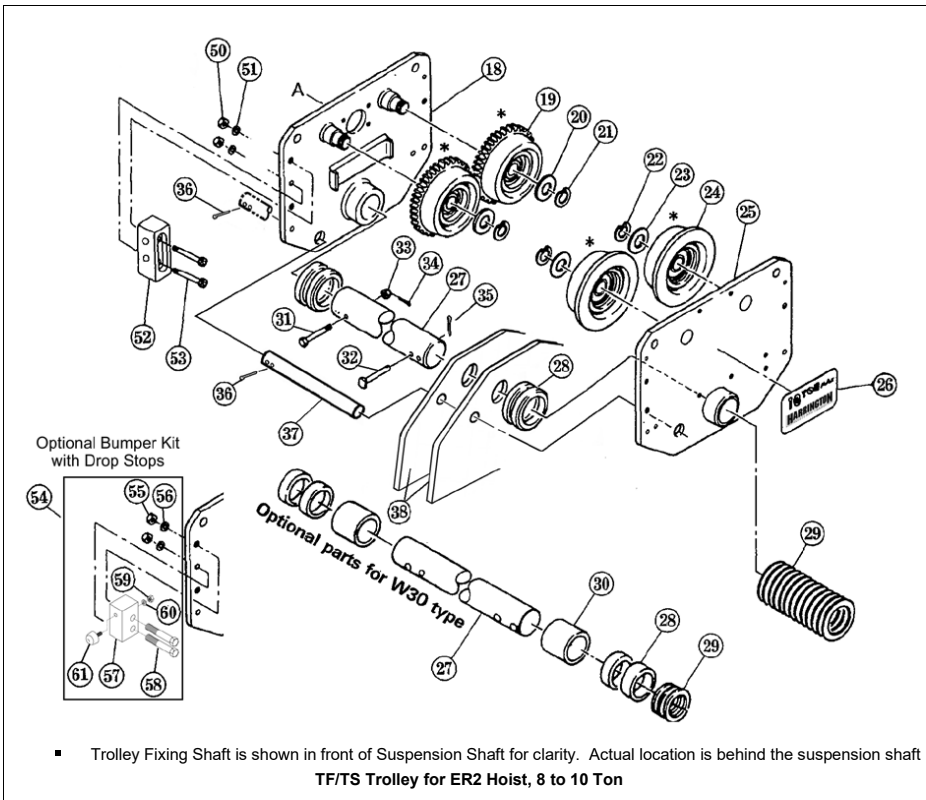

8.6 TF/TS Push/Geared Trolley Parts for ER2 Hoist – 8 to 10 Ton

Figure No.	Part Name	Parts Per Trolley		8 Ton	10 Ton
1	Hand wheel Assembly	Geared	1	T3G123ASM075	
2	Slotted nut		1	T3P154050	
3	Washer		1	9012515	
4	Hand wheel		1	T3G123ASM075	
5	Split Pin		1	9009423	
6	Snap ring		2	9047130	
7	Ball bearing		2	9000506	
8	Pinion		1	T3GB1009121	
9	Socket bolt		4	9091272	
10	Spring washer		4	9012711	
11	Hand chain guide		2	T3G125075	
12	Socket bolt		4	9091295	
13	Spring washer		4	9012712	
14	Pinion holder		1	T3B1009122	
15	Ball bearing		2	9000506	
16	Snap ring		2	9047130	
17	Hand chain	1	HCCF005		
18	Side plate G Assembly	1	T3G5111075		
19	Track wheel G Assembly	2	T3G1101075		
20	Washer	4	MS104075		
21	Snap ring	4	9047140		
22	Snap ring	4	9047140		
23	Washer	4	MS104075		
24	Track wheel S assembly	2	T3G1102075		
25	Side plate S assembly	1	T3G5110075		
26	Name plate B	Push	1	T3P800080	T3P800100
		Geared	1	T3G800080	T3G801100
27	Suspension Shaft	Std.	1	MS115075	
		Wide		MSF181075	
28	Thick spacer*	8	MS117075		
29	Thin spacer*	Std.	8	MS116075	
		Wide	9		
30	Fixing spacer	Wide	2	M6SE100S9182	
31	Bolt		1	MS161100	
32	Shaft stopper pin		1	MS164075	
33	Slotted nut		1	T3G154075	
34	Split pin		1	9009436	
35	Split pin		1	9009436	
36	Split pin, Trolley Fixing Shaft**		2		
37	Trolley Fixing Shaft**		1		
38	Hoist Suspension Plates**		2		
50	Nut	TS (Not compatible with bumpers)	8	9093439	
51	Spring washer		8	9012715	
52	Drop Stop		4	T5AB0759141	
53	Socket bolt		8	90912156	
54	Bumper kit	Optional for TF or TS	4	6078501	
55	Nut		4	9093439	
56	Spring washer		8	9012715	
57	Drop Stop		8	60818	
58	Socket bolt		4	9093196	
59	Nut		8	9093424	
60	Spring washer		4	9012711	
61	Bumper		4	MR1FS9631	

*See owner's manual for placement of thick and thin spacers.

**These parts come with the hoist and are not included with the trolley

8.7 TF/TS Geared Trolley Parts for CB Hoist – 15 to 20 Ton

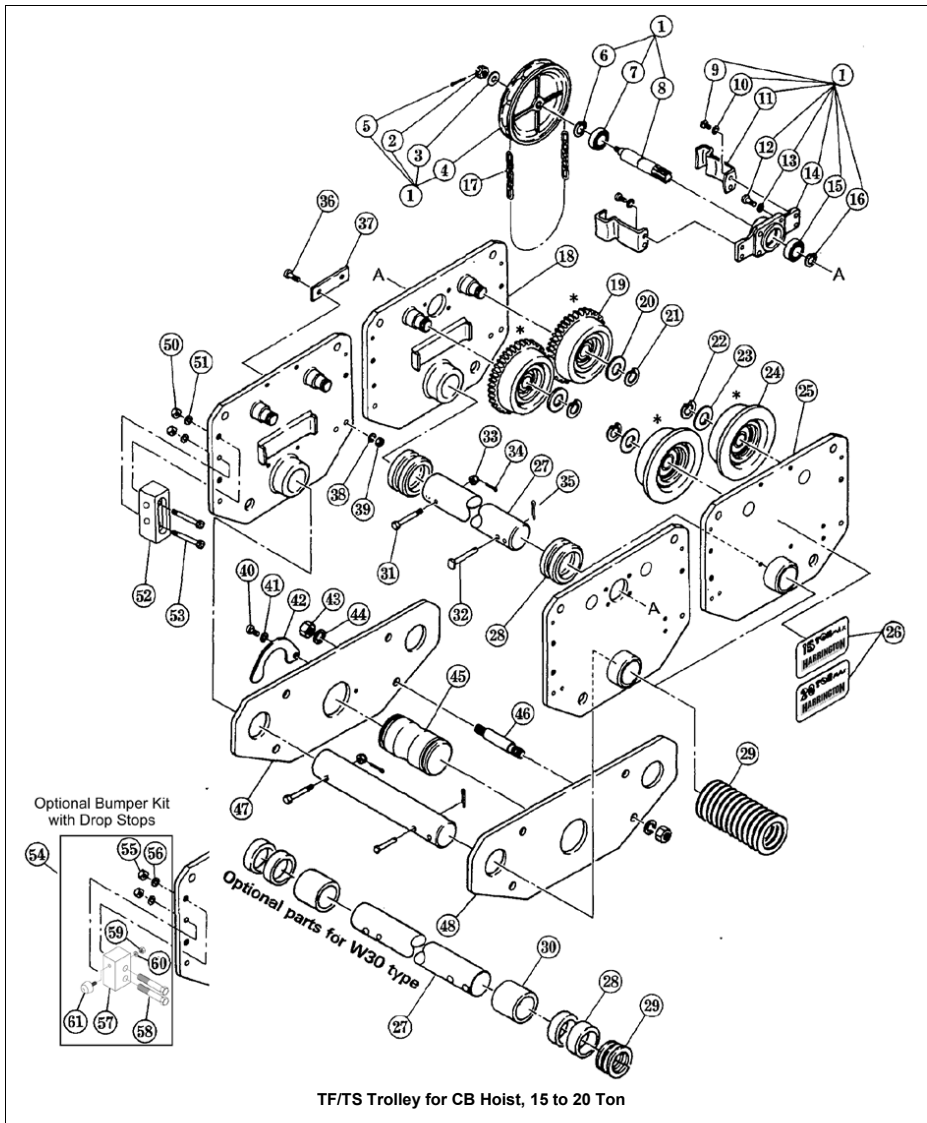

8.7 TF/TS Geared Trolley Parts for CB Hoist – 15 to 20 Ton

Figure No.	Part Name	Parts Per Trolley		15 Ton	20 Ton
1	Hand wheel Assembly	Geared	2	T3G123AM075	
2	Slotted nut		2	T3G154050	
3	Washer		2	9012515	
4	Hand wheel		2	T3G123075	
5	Split Pin		2	9009423	
6	Snap ring		4	9047130	
7	Ball bearing		4	9000506	
8	Pinion		2	T3G127100	
9	Socket bolt		8	9091272	
10	Spring washer		8	9012711	
11	Hand chain guide		4	T3G125075	
12	Socket bolt		8	9091295	
13	Spring washer		8	9012712	
14	Pinion holder		2	T3G128100	
15	Ball bearing		4	9000506	
16	Snap ring		4	9047130	
17	Hand chain	2	HCCF005		
18	Side plate G Assembly	2	T3G5111075		
19	Track wheel G Assembly	4	T3G1101075		
20	Washer	8	MS104075		
21	Snap ring	8	9047140		
22	Snap ring	8	9047140		
23	Washer	8	MS104075		
24	Track wheel S assembly	4	T3G1102075		
25	Side plate S assembly	2	T3G51110075		
26	Name plate B	2	T3G801150	T3G801200	
27	Suspension Shaft	Std.	2	MS115075	
		Wide		MSF181075	
28	Thick spacer*	Std.	6	MS117075	
		Wide		22	
29	Thin spacer*	Std.	20**	MS116075	
		Wide		16	
31	Bolt	2	MS161100		
32	Shaft stopper pin	2	MS164075		
33	Slotted nut	2	T3G154075		
34	Split pin	2	9009436		
35	Split pin	2	9009436		

*See owner's manual for placement of thick and thin spacers.

**For flange widths between 5 ½ to 5 ¾, six (6) additional thin spacers are required (for a total of 26 thin spacers).

8.7 TF/TS Geared Trolley Parts for CB Hoist – 15 to 20 Ton

Figure No.	Part Name	Parts Per Trolley	15 Ton	20 Ton
36	Bolt	4	MS106150	
37	Connection plate	2	MS105150	
38	Spring washer	4	9012713	
39	nut	4	9093433	
40	Bolt	1	9093327	
41	Spring washer	1	9012711	
42	Key plate	1	T3G145150	
43	Nut	8	9093445	
44	Spring washer	8	9012717	
45	Suspension shaft	1	T3G144150	
46	Stay bolt	4	T3G143150	
47	Suspension plate A	1	T3G141200	
48	Suspension plate B	1	T3G142150	
50	Nut	TS	8	9093439
51	Spring washer	(Not compatible with bumpers)	8	9012715
52	Drop Stop		4	T5AB0759141
53	Socket bolt		8	90912156
54	Bumper Kit		4	6078501
55	Nut		4	9093439
56	Spring washer		4	9012715
57	Drop Stop	Optional for TF or TS	8	60818
58	Socket bolt		8	9093196
59	Nut		4	9093424
60	Spring washer		8	9012711
61	Bumper		4	MR1FS9631

This Page Intentionally Left Blank

8.8 TF/TS Geared Trolley Parts for ER2 Hoist – 15 to 20 Ton

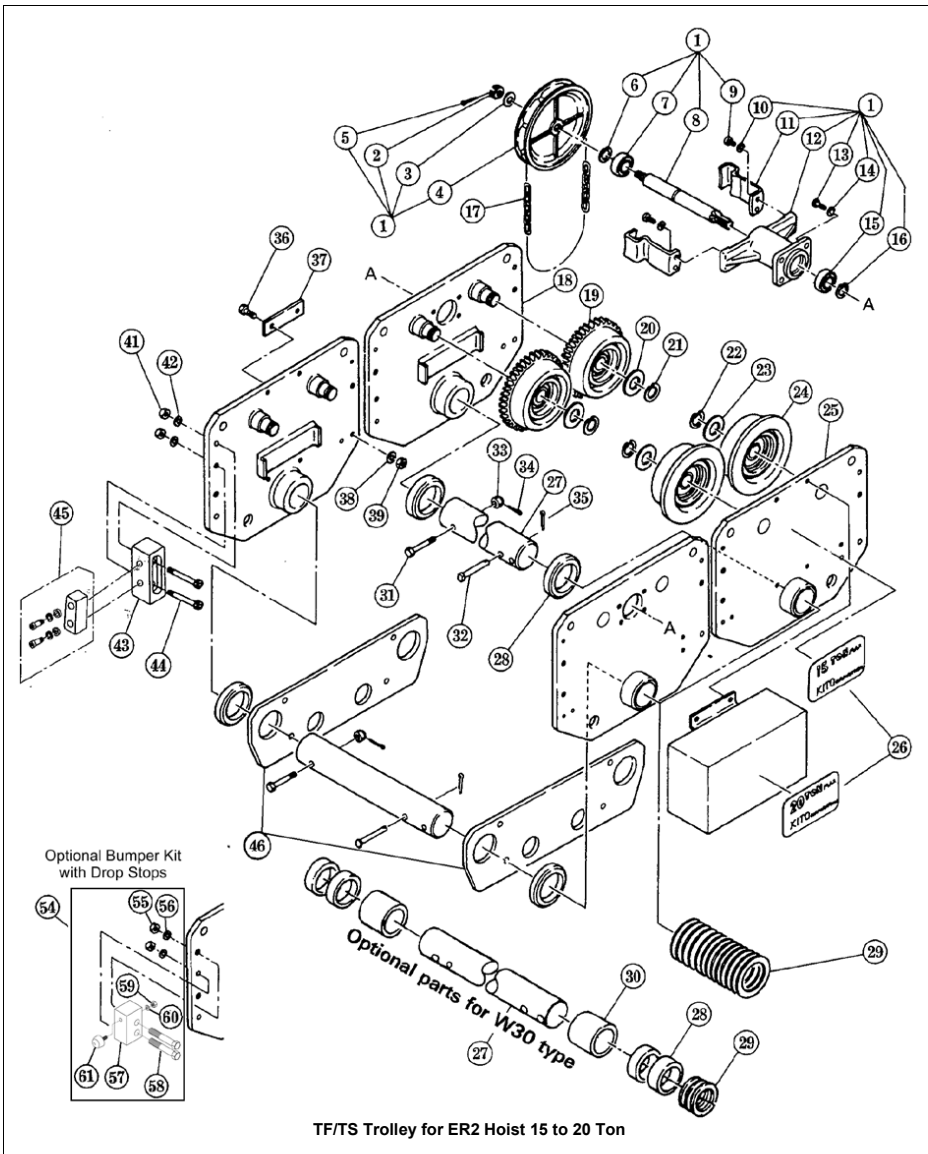

8.8 TF/TS Geared Trolley Parts for ER2 Hoist – 15 to 20 Ton

Figure No.	Part Name	Parts Per Trolley		15 Ton	20 Ton
1	Hand wheel Assembly	Geared	2	T3G123ASM075	
	2 Slotted nut		2	T3G154050	
	3 Washer		2	9012515	
	4 Hand wheel		2	T3G123075	
	5 Split Pin		2	9009423	
	6 Snap ring		4	9047130	
	7 Ball bearing		4	9000506	
	8 Pinion		2	T3GB1009121	
	9 Socket bolt		8	9091272	
	10 Spring washer		8	9012711	
	11 Hand chain guide		4	T3G125075	
	12 Pinion holder		2	T3GB1009122	
	13 Socket bolt		8	9091295	
	14 Spring washer		8	9012712	
	15 Ball bearing		4	9000506	
	16 Snap ring		4	9047130	
17	Hand chain	2	HCCF005		
18	Side plate G Assembly	2	T3G5111		
19	Track wheel G Assembly	4	T3G1101075		
20	Washer	8	MS104075		
21	Snap ring	8	9047140		
22	Snap ring	8	9047140		
23	Washer	8	MS104075		
24	Track wheel S assembly	4	T3G1102075		
25	Side plate S assembly	2	T3G5110075		
26	Name plate B	2	T3G801150	T3G801200	
27	Suspension Shaft	Std.	2	MS115075	
		Wide		MSF181075	
28	Thick spacer*	Std.	6	MS117075	
		Wide	22		
29	Thin spacer*	Std.	20**	MS116075	
		Wide	16		
31	Bolt	2	MS161100		
32	Shaft stopper pin	2	MS164075		
33	Slotted nut	2	T3G154075		
34	Split pin	2	9009436		
35	Split pin	2	9009436		
36	Bolt	4	MS106150		
37	Connection plate	2	MS105150		
38	Spring washer	4	9012713		
39	Nut	4	9093433		
41	Nut	TS	8	9093439	
42	Spring washer	(Not compatible with bumpers)	8	9012715	
43	Bumper		4	T5AB0759141	
44	Socket bolt		8	90912156	
46	Hoist Suspension Plates†				
54	Bumper Kit	Optional for TF or TS	4	6078501	
	55 Nut		4	9093439	
	56 Spring washer		4	9012715	
	57 Drop Stop		8	60818	
	58 Socket bolt		8	9093196	
	59 Nut		4	9093424	
	60 Spring washer		8	9012711	
	61 Bumper		4	MR1FS9631	

*See owner's manual for placement of thick and thin spacers.

**For flange widths between 5 1/4 to 5 7/8", six (6) additional thin spacers are required (for a total of 26 thin spacers).

†Hoist Suspension Plates come with the hoist and are not included with the trolley.

This Page Intentionally Left Blank

This Page Intentionally Left Blank



Harrington Hoists, Inc.
401 West End Avenue
Manheim, PA 17545

www.harringtonhoists.com

Toll Free: 800-233-3010
Phone: 717-665-2000
Fax: 717-665-2861

© Harrington Hoists, Inc.
All Rights Reserved

TF2TS2OM-ENG