

**JDN OPERATION AND ASSEMBLY
INSTRUCTIONS FOR AIR HOISTS**
PROFi25Ti PROFi37Ti PROFi50Ti



Original operation and assembly instructions



J.D. NEUHAUS
powered by air!

Please enter the Serial No. of your JDN Air Hoist here.

These operation instructions, edition 03/2012, cover the following JDN Air Hoists:

PROFI 25 Ti

Serial No.

PROFI 37 Ti

Serial No.

PROFI 50 Ti

Serial No.

The operation instructions must be read carefully in their entirety before operating any hoist. For hoists installed in trolleys, also refer to the **JDN Trolley** operation instructions.



J.D.NEUHAUS
powered by air!

CONTENTS

SAFETY MEASURES

Organisational measures	6
Personnel safety	6
Preventing property damage	6

PRODUCT INFORMATION

About these operation instructions	7
Warnings and symbols	7
Identification	8
Assembly overview	9
Product description	9
Type of operation	10
Explosion protection	10
Intended use	16
Emissions	17
Operating conditions	17
Principle of operation of JDN air vane motors	18
Operation without chain box	19
Motor lubrication/operation with a service unit	19
CE DESIGNATION/INSTALLATION DECLARATION	19
Spare parts	19

APPLICATION

Area of application	20
Attachment points	20
Energy requirements	20

TRANSPORT AND STORAGE

Safe transportation	21
Storage conditions	21

INITIAL OPERATION

Unpacking	22
Assembly	22
Installing the hoist	22
Controls	23
Connecting the controls	24
Connecting to the main air supply	27
Lubricants	28
Inspection before initial operation	29
Initial operation	29

OPERATION

Rules for safe operation	30
Controls	33
Emergency stop	35
Overload protection	35
Load hook mount	35
Chain	36
Load hook	37
Attaching the load	37
Lifting the load	38
Lowering the load	38
Detaching the load	38
Interrupting working	38

TAKING OUT OF OPERATION

Shutting down	39
Storage	39
Dismantling	39
Disposal	39

MAINTENANCE

Maintenance and inspection intervals	40
Cleaning and care	40
Spare parts	40
Lubricants	40
Inspection and repairs	40
Instructions concerning the "model for determining the actual operating time"	42
Lubricating the chain	46
Checking braking function	46
Checking lifting and lowering limiters	47
Checking controls and emergency stop function	47
Checking direction of movement	47
Checking silencer for permeability	47
Service unit	48
Filling and adjusting oiler	49
Motor installation and inspection	50
Motor lubrication	51
Removing and installing bottom block, clamp and buffer	52
Removing and installing chain	56
Replacing chain and chain sprocket	57
Checking chain, chain sprocket and chain guides	58



MAINTENANCE

Check dimensions	58
Checking axial play	60
Checking and adjusting overload protection	61

FAULTS, CAUSES AND REMEDIES

Troubleshooting guide	62
-----------------------	----

ACCESSORIES

Filter silencer	63
Booster unit	63
Chain box	64

APPENDIX

Technical data	65
Dimensions	66
Circuit diagram	67



Please note:

Within the Federal Republic of Germany operators of air hoists must comply with trade association accident prevention regulations and rules, as well as state occupational safety regulations, in particular

- ▶ BGV A1 accident prevention regulations "Principles of Prevention"
- ▶ BGV D8 accident prevention regulations "Winches, Lifting and Pulling Devices"
- ▶ BGR 258 trade association regulations "Operation of Load-Carrying Devices Used with Lifting Equipment"

and, for air hoists installed in trolleys, additionally with

- ▶ BGV D6 "Accident Prevention Regulations for Cranes"

in the respective currently applicable version. Operators must also initiate the prescribed tests (see also "Principles for the Testing of Cranes" BGG 905 (ZH 1/27)).

To document the tests we recommend the "Inspection log for cranes" BGG 943 (ZH 1/29) from the trade association.

When operating air hoists in areas with explosive atmospheres, the operator must comply with the relevant explosion protection regulations, e.g.

- ▶ BGR 104 "Explosion Protection Regulations" and
- ▶ BGR 132 "Prevention of Ignition Hazards due to Electrostatic Charges"

In all other countries, the operator must comply with local regulations as applicable.

Special regulations may apply when installing air hoists in plants or when using under unusual conditions.



SAFETY MEASURES

ORGANISATIONAL MEASURES

JDN Hoists are designed in accordance with current technological standards and accepted safety practice. Nonetheless, the use of a hoist may be associated with risk of injury or fatality to the user or to third parties or with the risk of damage to the hoist or to other items, if safety rules are disregarded.

All personnel charged with operating hoists, must have read and understood the operation instructions, especially the section entitled "Rules for the safe operation of hoists", before commencing work. This is particularly important for personnel who only occasionally operate the hoist, e.g. for maintenance or retrofitting work.

Operators of JDN Hoists are also under obligation to ensure safe and hazard-free operation. This can be achieved through the following measures:

- ▶ Keeping the operation instructions available at the hoist operating site at all times.
- ▶ Holding training courses on a regular basis.
- ▶ Performing regular inspections (at least once annually).
- ▶ Providing an inspection log and updating regularly.
- ▶ Checking personnel regularly for safety and hazard awareness during work.

PERSONNEL SAFETY

Personnel who operate, maintain, inspect and perform setting-up work on the hoist must be properly trained or must receive an introduction from properly trained personnel before commencing work.

Due to their technical training and experience, properly trained personnel have adequate knowledge of hoists. They are sufficiently familiar with the relevant occupational safety and accident prevention regulations that they are able to assess the condition of hoists with regard to working safety.

- ▶ Follow the operating instructions for your workplace.
- ▶ Comply with the Accident Prevention Regulations.
- ▶ Obtain proper briefing on the handling of hazardous materials.
- ▶ Follow the safety warnings set out in the operation instructions.

PREVENTING PROPERTY DAMAGE

Operators of JDN Hoists are under obligation to ensure that entries in the accompanying inspection log are made properly and regularly.

- ▶ Comply with the prescribed maintenance intervals.
- ▶ Only use JDN Hoists for work which is described as intended use.
- ▶ Observe the operating conditions for JDN Hoists as described in these instructions.



PRODUCT INFORMATION

ABOUT THESE OPERATION INSTRUCTIONS

These operation instructions are intended to help the operator to become familiar with JDN Air Hoists and their intended use.

These operation instructions contain important information for the safe, proper and efficient operation of JDN Air Hoists. Observance of the instructions helps to avoid hazardous situations, to reduce repair costs and downtimes and to extend the service life of the JDN Air Hoists.

Keep the operation instructions available at the JDN Air Hoist operating site,

All persons charged with operating, maintaining or repairing JDN Air Hoists must read and follow these operation instructions.

WARNINGS AND SYMBOLS

Safety warnings in these operation instructions are classified in three categories:



DANGER!

Safety warnings which, if not followed, can result in danger to life and limb, are indicated by this symbol. The symbol indicates an immediate danger. The possible consequences of non-observance may be severe or even fatal injuries.



CAUTION!

This symbol indicates potentially hazardous situations. Failure to observe may result in minor injuries.



ATTENTION!

This symbol indicates that failure to follow the relevant instructions may result in damage to the device or other items.



MARKING

The nameplate mounted on the housing cover identifies the type of JDN Air Hoist and contains all important rating data.

If you have any questions concerning operation of JDN Air Hoists, which are not addressed in these operation instructions, please contact us at the following address:

J.D. NEUHAUS GMBH & CO. KG Windenstraße 2-4
D - 58455 Witten-Heven

Phone 02302 208-0
Fax 02302 208-286
www.jdn.de
e-mail: info@jdn.de

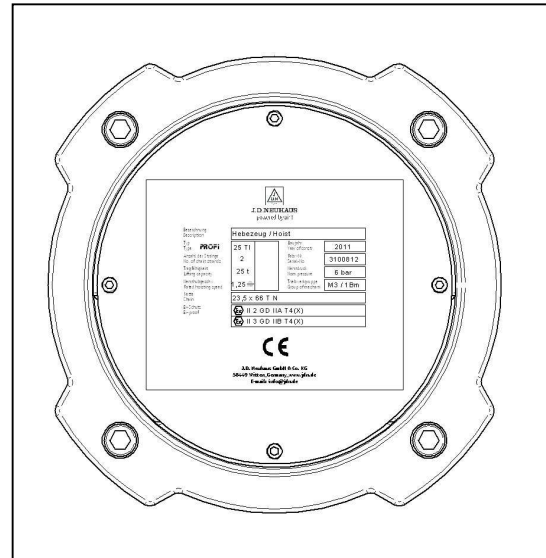

Example of a nameplate on the housing cover



ASSEMBLY OVERVIEW

PROFI TI series air hoists consist of the following assemblies:

- 1 Gearbox with outlet air cooling
- 2 Centre section with chain sprocket
- 3 Motor with integrated braking function
- 4 Control valve with integrated main-stream valve
- 5 Load hook with bottom block and buffer

PRODUCT DESCRIPTION

The PROFI 25 - 50TI series JDN Air Hoists described here are designed for load-carrying capacities of 25 t (PROFI 25 TI), 37 t (PROFI 37TI) and 50 t (PROFI 50 TI). Various control devices are available for the different requirements.

The air vane motor of the hoist, together with the appropriate controls, is capable of sensitive movement. This enables precise positioning of the load.

The motors of the PROFI 25° - 50 TI JDN Air Hoists feature rotors with patented grease chambers. These contain JDN high-performance grease which enables operation with oil-free compressed air. It remains effective for an operating period of approx. 250 hours and should be renewed when required, but after five years at the latest (see **Motor lubrication**, page 51). Additional lubrication with oil-bearing compressed air by means of a service unit and oiler is optionally possible.

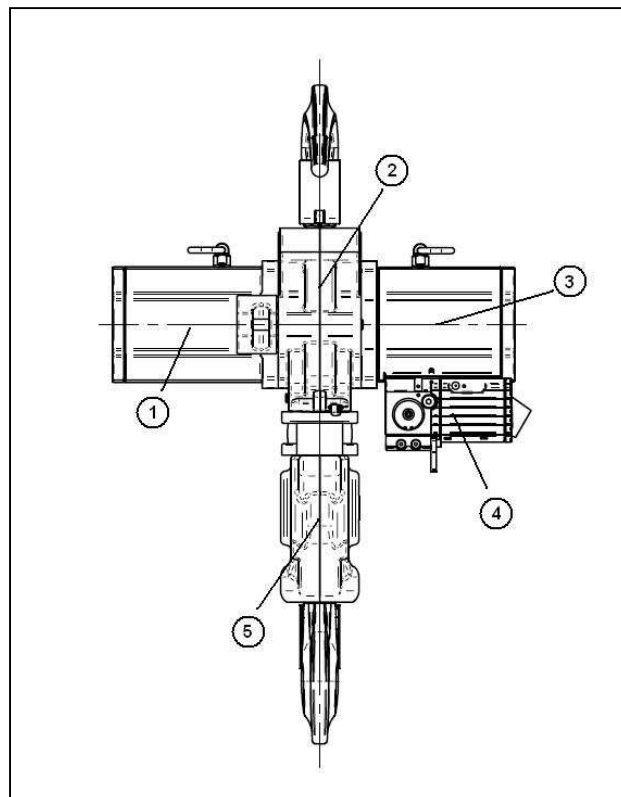

PROFI TI series JDN Air Hoists

TYPE OF OPERATION

JDN Air Hoists conform to driving mechanism classification 1 **Bm/M3** (according to FEM/ISO)¹.

Series-built hoists have a limited service life. After the theoretical service life, the hoist must undergo special checks (see **Inspection and repairs**, page 40).

1) FEM: Fédération Européenne de la Manutention – European Federation for Conveyor Technology



J.D. NEUHAUS
powered by air!

EXPLOSION PROTECTION

The basis for the following information is an expert statement by the DMT Gas & Fire Division on the use of JDN Hoists, Trolleys and Crane Systems in potentially explosive areas and is based on European Directive 94/9/EC¹ ("ATEX 100a"). DMT is accredited with the testing of devices and protection systems for intended use in explosion-hazardous areas.

BASIC EXPLOSION PROTECTION FOR THE STANDARD VERSIONS

Standard version JDN Air Hoists are category 2 devices (Guideline 94/9/EC, DIN EN 1127-1²), for use in zone 1 and 2 for gases of explosion group IIA. (See also IEC 60079-12³ and IEC 60079-20⁴.) These devices are also suitable for use in zone 2, in the presence of gases of explosion group IIB, provided that the substances hydrogen sulphide and ethylene oxide can be excluded and additionally in zones 21 and 22 for dusts with glow temperatures above 210°C or ignition temperatures above 202°C, provided that no light metal or other impact-sensitive dusts are present.

These devices are designated by:

⊕ II 2 GD IIA T4(X)/II 3 GD IIB T4(X)

Additional designation "X", see page 11.

JDN HOISTS "WITH INCREASED SPARK PROTECTION"

JDN hoists of the version "with increased spark protection" (FS) satisfy additional explosion protection requirements. They can be employed with all gases - except for carbon disulfide - (temperature class T6) in zones 1 and 2 and dusts with glow temperatures in excess of 210°C and ignition temperature in excess of 202°C in zones 21 and 22, and bear the following highest possible designations: **II 2 GD IIC T4(X)** for installation in a trolley, depending on the trolley version (see below) but also with **II 2 GD IIB T4(X)**. For further operating conditions, see Instructions for safe operation (Notes D and E).

JDN HOISTS FOR USE IN THE PRESENCE OF TEMPERATURE CLASS T6 GASES OR EXTREMELY EXPLOSIVE DUSTS

Following separate tests, especially with regard to ambient temperatures and type of operation, use in the presence of carbon disulphide or dusts with particularly low glow or ignition temperatures may be possible with designation

⊕ II 2 GD IIC T6(X), which includes the supplementary identifier "X" for special conditions (see additional marking "X"). Please contact us with regard to these requirements.

STANDARD JDN TROLLEY AND CRANE RUNNING GEAR

JDN trolleys and cranes can be used in zone 2 with standard running wheels (made of steel or cast metal) with all dusts and the presence of gases up to explosion group IIC. Due to the low running speeds, the possible friction velocities on the running wheels are less than 1 m/s, so that standard running wheels can also be used in zone 1 up to explosion group IIB. The highest possible designation for these devices is:

⊕ II 2 GD IIB T4(X)/II 3 GD IIC T4(X).

Depending on the hoist version, it may also have the designations

⊕ II 2 GD IIA T4(X)/II 3 GD IIB T4(X) or

⊕ II 2 GD IIB T4(X).

JDN TROLLEY AND CRANE RUNNING GEAR "WITH INCREASED SPARK PROTECTION"

For use in zone 1 in the presence of gases in explosion group IIC, bronzed running wheels or running wheels made of bronze are also used. The highest possible designation for this version (FSR) is

⊕ II 2 GD IIC T4(X) (the same as for JDN hoists "with increased spark protection").

JDN TROLLEY AND CRANE RUNNING GEAR FOR USE IN THE PRESENCE OF TEMPERATURE CLASS T6 GASES OR DUSTS

As is the case with JDN hoists "with increased spark protection", temperature class T6 is also possible here in the case of a special investigation of applicability, permitting the highest possible designation for standard wheels **II 2 GD IIB T6(X)/II 3 GD IIC T6(X)** and for bronzed or bronze wheels

⊕ II 2 GD IIC T6(X), i.e. the supplementary identifier "X" for special conditions in each case.



GENERAL NOTE ON DESIGNATION

The highest possible respective designations for lifting equipment and running gear are usually replaced by a designation which corresponds to the normal assembly of a compact complete device (trolley or crane system).



ADDITIONAL DESIGNATION "X"

This designation refers to explosion protection details in the operation instructions.

 II 2 GD IIA T4(X)/II 3 GD IIB T4(X) or

 II 3 GD IIA T4(X):

This designation does not permit use in the presence of the extremely flammable substances hydrogen sulphide and ethylene oxide or in the presence of light metal or other impact-sensitive dusts, or in the presence of dusts with glow temperatures below 210°C or ignition temperatures below 202°C. The permissible ambient temperature range (Ta) extends from - 20°C to + 70°C.

 II 2 GD IIC T4(X) or  II 2 GD IIB T4(X): The permissible ambient temperature range (Ta) extends from - 20°C to + 70°C.

 ... II C T6(X):

This designation permits use in the presence of carbon disulphide or other temperature class T6 substances only under special conditions, which have been agreed with the manufacturer and which are described in the crane documentation and which stipulate the maximum surface temperatures for the device.

USE IN MINING APPLICATIONS

Standard versions of JDN hoists, trolleys and crane systems may generally also be used for underground mining operations as well as for the associated surface facilities, which are hazardous due to firedamp and/or combustible dusts. Within this equipment group I they belong to category M2.

They constitute devices which can be switched off in cases where an explosive atmosphere forms. They are equipped with protective measures offering a high degree of safety. The protective measures with which products of this category are equipped provide the necessary degree of safety for normal operation as well as operation under difficult conditions, in particular rough treatment and changing environmental influences.

For hazardous conditions above and beyond explosion protection, prevailing with regard to the general use of the devices in mining applications, special mining hoists are available from J. D. NEUHAUS. The maximum permissible temperature of 150°C in accordance with EN 13463-1⁵ for coal dust atmospheres is not reached. For mining applications, the relevant designation for hoists, trolleys and crane systems is **I M2**.

LOAD CHAIN

In order to guarantee the required degree of earthing, rusty chains must no longer be used in zones 1 and 21. This is due to the fact that, depending upon the degree of corrosion, the leakage capability of the chain may be impaired to a level that is no longer adequate.

COMPRESSED-AIR HOSES

In zone 1, compressed air hoses must have a sufficiently low surface resistance of less than $10^9 \Omega$ in order to prevent electrostatic ignition hazards. Otherwise (resistance $>10^9 \Omega$), for explosion groups I, IIA and IIB the hoses must be $\varnothing \leq 30$ mm and for explosion group IIC, $\varnothing \leq 20$ mm or proof must be provided that they cannot become dangerously charged.

MATERIALS FOR FRICTION AND IMPACT HAZARDS

Friction and impacts can give rise to individual sparks presenting a danger of ignition in the presence of explosion group IIC gases, hydrogen sulphide, ethylene oxide, or light-metal and other impact-sensitive dusts. Therefore, spark formation caused by mechanical influences must be prevented.

The chain and load must always be moved in such a way that sliding and/or frictional contact with other plants or components is excluded. If circumstances do not permit this, it is necessary to ensure an absence of explosive atmospheres during operation.

Impacts between particular materials result in an increased ignition hazard. This does not apply to corrosion-resistant steel or cast iron against aluminium, magnesium or corresponding alloys.



This applies especially in the presence of rust or rust film. Rust (also rust film) formation is possible, especially on the chain and on the load hook, at the friction points. The following applies to all zones: For the intended use of hoists it must be ensured, that no rust is present at the above-mentioned friction points and that material combinations of the above-named light metals with steel (exception: stainless steel) are not used in the working area of the hoists, at potential friction, impact or sliding points. It is thus possible to exclude sparking due to mechanical influences with these material combinations.

The external housing of the service units is made of aluminium. Therefore, the installation position is to be selected so as to ensure that there is no risk from impact sparks.

EARTHING

Electrostatic ignition hazards can be prevented by means of safe earthing. In zones 1 and 21, earthing of the hoists is required. This must be achieved via the load hook or the load eyes provided that the lifting equipment is connected to correspondingly earthed parts (earth leakage resistance less than $10^6 \Omega$). This also applies to operation with trolleys or cranes. Their tracks must be earthed on site. Running wheels and rail surfaces must never be painted, as this can result in unacceptably high earth leakage resistance values.

Earthing of the load hook is via the chain (see also **Load chain**, page 11).

Loads must be earthed during transportation. A separate earth is required, for example, when using non-conducting sling gear.

CLEANING PLASTIC SURFACES

Where JDN Air Hoists or JDN Air Winches feature plastic parts, these surfaces must only be cleaned using a damp cloth (cleaning cloth with water). This reduces electrostatic charging that can arise due to mechanical friction at the plastic surface.



DANGER!

Electrostatic charging may occur at the plastic surfaces, potentially leading to electrostatic discharge that can ignite gases and air mixtures.

ACETYLENE AND COPPER

When operating JDN products in explosion-hazardous areas, in which an acetylene-containing atmosphere can occur, it must be ensured that copper-plated parts are kept dry in order to exclude the possibility of oxidation of the metallic copper and the formation of an aqueous phase, which is capable of reacting with acetylene and which can result in an explosion hazard.



EXPLOSION GROUPS AND TEMPERATURE CLASSES OF THE MOST IMPORTANT GASES AND VAPOURS (-SELECTION-)

(according to DIN VDE 01656, Redeker⁸, Nabert, Schön⁷, IEC 60079-12³ and IEC 60079-20⁴)

Explosion protection group	Temperature class					
	T1	T2	T3	T4	T5	T6
	Ignition temperature					
	> 450°C	450-300°C	300-200°C	200-135°C	135-100°C	100-85°C
Maximum permissible surface temperature of operating facilities						
	450°C	300°C	200°C	135°C	100°C	85°C
II A	Acetone Ammonia Aniline Benzene Chlorobenzene 1,2 Dichlorobenzene Acetic acid Ethane Ethyl acetate (ethyl bromide) Ethyl chloride (carbon monoxide) o-Cresol Methane Methyl acetate Methyl alcohol*1 Methyl bromide Methyl chloride Methylene chloride Naphthalene (nitrobenzene) Phenol Propane Toluene o-Xylene	(ethyl alcohol) (ethylene glycol) i- Amyl acetate n-Butane n-Butyl alcohol 1-Butylene 1,2 Dichlorethane Di-i-propyl ether Natural gas Acetic anhydride n-Propyl acetate (n-Propyl alcohol) i-Propyl alcohol Vinyl chloride	n-Amyl alcohol Petrol (fuel) Diesel Heating oil n-Hexane Jet fuels	Acetaldehyde		
II B	Hydrocyanic acid (ethyl bromide) (carbon monoxide) (nitrobenzene) Town gas	Butadiene-1,3 Dioxane-1,4 Divinyl ether (ethyl alcohol) Ethylene (ethylene glycol) **Ethylene oxide Isoprene (n-Propyl alcohol)	Dimethyl ether **Hydrogen sulphide	Ethyl ether Ether Anaesthetic ether Diethyl ether		
II C	**Hydrogen	**Acetylene				**Carbon disulphide

(): The measured values for the substances placed in brackets are close to the limit or the next group or class when classified in the explosion groups or temperature classes. For this reason, they have been included in both.

** : Extremely flammable substances (cf. additional designation "X")

*1 (Methanol = methyl alcohol)



DECISION CRITERIA FOR SELECTING THE CORRECT JDN HOISTS IN EXPLOSION-HAZARDOUS AREAS

Explosion groups for gases and vapours (cf. explosion groups and temperature classes for the most important gases and vapours)	Zone	Version*1			Operation*2		
II A	2	A				E	
	1	A				E	
II B (X) except hydrogen sulphide, ethylene oxide (highly flammable)	2	A				E	
	1	A	FS			E	
II B	2	A	FS		D	E	
	1	A	FS		D	E	
II C / T4	2	A	FS		D	E	
	1	A	FS	FSR	D	E	
II C / T6(X)	2	A	FS		D	E	T
	1	A	FS	FSR	D	E	T
Potentially explosive dusts	Zone	Version*1			Operation*2		
Normal industrial dusts	22	A				E	
	21	A				E	
Light metal or impact-sensitive dusts	22	A	FS		D	E	
	21	A	FS		D	E	

*1: Features:

- A: The chain is made of galvanised steel; metal controls are conductively connected to the hoist. This is part of the standard equipment. For technological reasons, a galvanised version of chain size 31.5 x 90 is not available. This is only used for the extremely slow-running chain drives of large hoists, so that the sliding velocity for potential friction points between the chain and the surroundings remains well below 1 m/s.
- SP: Hoists "with increased spark protection": Copper-plated load hook and bottom block with brass safety catch.
- FSR: Running gear "with increased spark protection": Running wheels for trolleys and cranes are bronzed or are made of bronze.

*2: Instructions for safe operation:

- D: Ignition hazards are not to be expected if hoists or cranes are used for their intended purpose. Friction and impacts in the working area of the chain, not resulting from intended use of the hoist or crane and which result in sparking, must be excluded. This applies in particular to use in conjunction with light metals or light metal alloys. (exception: stainless steel)
- E: A gas-free or spark-free environment must be ensured in the working area. This means, for example, that the chain, the bottom block and the load hook must be prevented from swinging against surrounding objects or that a gas-free environment must be ensured.
- T: Ambient temperature and the type of operation must be examined separately. Equipment surface temperatures are dependent upon the type of operation and the ambient temperature. Therefore, separate testing is required for materials of temperature classes T5 and T6. A maximum ambient temperature of 40°C is a pre-condition for the specification of temperature class (see also EN 500149).



TEMPERATURE LIMITS FOR EXPLOSION-HAZARDOUS DUSTS

In areas that are potentially explosive due to combustible dusts, the surface temperature must not exceed two-thirds of the ignition temperature in °C of the dust/air mixture. The temperatures of surfaces on which hazardous deposits of combustible dusts can be formed, must not exceed the glow temperature of the relevant dust minus 75°K. Greater safety margins are required if the thickness of the dust layer exceeds 5 mm.

The corresponding surface temperatures can be derived from the lowest values for glow and ignition temperatures of dusts specified in the HVBG/BIA Report 12/9710 "Combustion and explosion characteristics of dusts":

Synthetic rubber, soot-containing:

Glow temperature	$220^{\circ}\text{C} - 75^{\circ}\text{C} =$	145°C max.
	permissible	surface
	temperature	

Stearic acid:

Ignition temperature	$190^{\circ}\text{C} \times 2/3 =$	126°C max.
	permissible surface	
	temperature.	

PLEASE ALSO OBSERVE YOUR CORRESPONDING NATIONAL REGULATIONS.

- 1 Guideline 94/9/EC of the European Parliament and the Council dated 23 March 1994 on the adaptation of the laws of the Member States concerning equipment and protective systems intended for use in potentially explosive atmospheres
- 2 DIN EN 1127-1: Explosive atmospheres - Explosion prevention and protection - Part 1: Basic concepts and methodology, 1997-10
- 3 IEC 60079-12: Electrical apparatus for explosive gas atmospheres, Part 12: Classification of mixtures of gases and vapours with air according to their maximum experimental safe gaps and minimum igniting currents, 1978
- 4 IEC 60079-20: Electrical apparatus for explosive gas atmospheres, Part 20: Data for flammable gases and vapours relating to the use of electric apparatus, 1996-10.
- 5 EN 13463-1: Non-electrical devices intended for use in explosive areas - Part 1: Basic methodology and requirements, 07/2009
- 6 DIN VDE 0165: Installation of electrical systems in areas with explosion hazard, 1991
- 7 Nabert, Schön: Safety-related characteristic values for flammable gases and vapours, 2nd edition, 1978
- 8 Redeker, Schön: 6. Supplement to safety-related characteristic values for flammable gases and vapours, 1990
- 9 DIN EN 50014 (VDE 0170/0171 Part 1): 2000-02 Electrical apparatus for use in explosion hazardous areas: General provisions
- 10 HVBG/BIA Report 12/97: Central association of German employer's liability associations / trade association institute for industrial safety



INTENDED USE

JDN Air Hoists are designed for lifting and lowering loads within the specified load-carrying capacities, with a vertically-arranged chain. JDN Air Hoists from the PROFI 25 TI to 50 TI ranges are also suitable for pulling loads horizontally. Please also observe the individual national regulations. In combination with trolleys, JDN Air Hoists are also suitable for the floorless horizontal movement of loads.

Any other use or use outside these stipulations is deemed to be impermissible. Oblique pulling, see **Rules for safe operation of hoists**, page 30. J.D. NEUHAUS GMBH & CO. KG cannot be held liable for any resulting damage. The entire risk is borne by the user (see also section **Rules for safe operation of hoists**, page 30).

Intended use also includes observance of the operation instructions and compliance with the inspection and maintenance conditions.



EMISSIONS

Noise emissions

The noise emission data can be found in the **Technical data** table, page 65ff.

The noise pressure level of the measurement area at a distance of 1 m from the machine surface was measured in accordance with DIN 45 635, Part 20, at the operating air pressure specified by us. In the hall, the noise pressure level drops by approx. 3 dB (A) every time the distance is doubled.

Oil emissions

If the device is operated with motor oil lubrication, small amounts of lubrication oil will be released into the environment with the outlet air.

Oil emissions can be prevented by using a filter silencer (see **Filter silencer**, page 63). This also results in a reduction of the noise emission values.

OPERATING CONDITIONS

JDN Air Hoists are extremely robust and require little maintenance. They are suitable for use in potentially explosive areas, as well as in areas with increased concentrations of soot and dust, high humidity and at ambient temperatures of -20°C up to approx. $+70^{\circ}\text{C}$, assuming they are not heated above this level due to external influences. The thermal endurance of chains and hooks is $+150^{\circ}\text{C}$.



CAUTION!

When touching metallic hand controls which are colder than 0°C , freezing of the skin can occur within a few seconds and for temperatures above 43°C , burns can occur. As a protective measure, please wear suitable gloves.

For stationary outdoor operation, hoists must be protected against weathering and the maintenance intervals must be shortened.

Depending upon the version, JDN Air Hoists must be operated at a system pressure of 4 bar or 6 bar (see information on the nameplate). If the system pressure is too low, important functions of the hoist will be impaired:

- ▶ The brake will drag and is thus subject to a high degree of wear. An impermissibly high degree of heating may occur.
- ▶ The controls become noticeably less sensitive.



DANGER!

Warning against excessive system pressures

Operating with excessive system pressures results in danger due to overloading. Therefore, the pressure must be limited to that specified on the nameplate.

JDN Air Hoists must be operated with a sufficiently clean and dry air supply. The air supply must fulfil the following quality requirements:

- ▶ Particle size less than $40\ \mu\text{m}$
- ▶ Particle density less than $10\ \text{mg}/\text{m}^3$
(corresponds to Class 7 in accordance with ISO 8573-12001)

In order to provide adequate compressed air quality, operation with a filter regulator is recommended. An oiler is not required in the service unit, as the motor is provided with internal permanent lubrication.

- ▶ Pressure dew point must be at least 10°C below the lowest expected ambient temperature

Do not operate JDN Air Hoists with other gases.

With moist air and ambient temperatures at or below 0°C , there is a danger of icing in the motor.

Icing can be prevented by:

- ▶ the use of an upstream air dryer
- ▶ if a service unit with oiler is used, adding anti-icing agent to the lubrication oil (depending on moisture content of compressed air), or using pneumatic oil (Part No. 11900) with anti-icing additive for relevant temperature conditions.

In the event that your JDN Air Hoist is operated in combination with a trolley, please also read the trolley operation instructions and the relevant accident prevention regulations for operation with trolleys.



PRINCIPLE OF OPERATION OF JDN AIR VANE MOTORS

The vane motor consists of a cylinder liner 1 with two side bearing plates and an internal rotor 2.

The rotor 2 is mounted eccentrically in the cylinder liner 1 and is provided with slots 3 for installation of the vanes 4.

The vanes 4 can move freely and make contact with the inner wall 5 of the cylinder liner 1. Each chamber 6 is formed by two vanes.

Due to the incoming compressed air, a greater force is created at the leading, larger vane surface 4.1 than at the trailing, smaller vane surface 4.2. The difference in force generates the torque of the rotor 2.

As the chamber passes the outlet aperture 7, the compressed air can escape.

Lubricant chambers 8 are provided between the vane slots of the rotor 2. They ensure continual motor lubrication.

The arrows in the illustration indicate the direction of rotation of the rotor 2 and the corresponding path of the compressed air.

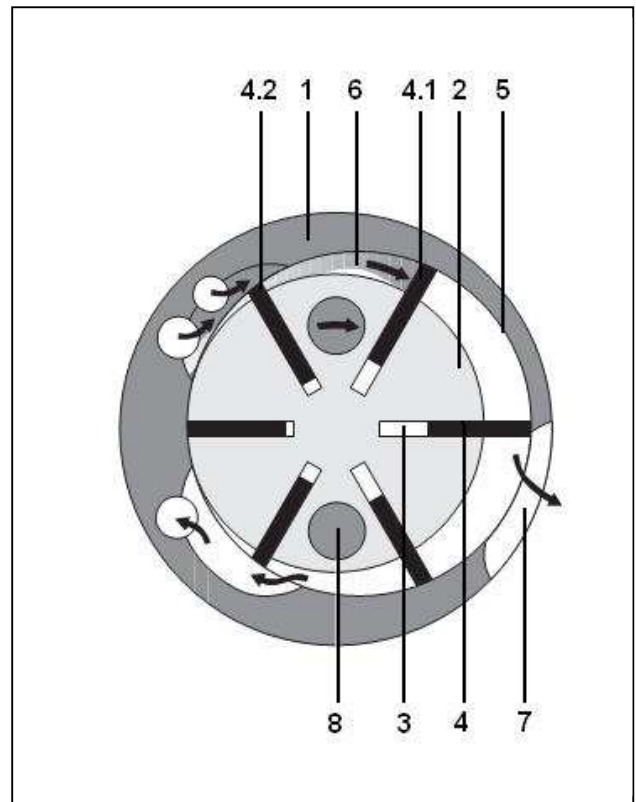

Vane motor for PROFI TI series JDN Air Hoists



OPERATION WITHOUT CHAIN BOX



DANGER!

If JDN Air Hoists are operated without a chain box, it must be ensured that the idle chain (unloaded chain end) running up or down at the chain sprocket, does not present a hazard, e.g. due to catching, impacting or falling.

Danger due to falling chain can also arise, if the idle chain is first deposited on a load with a large surface and then slides off and drops.

SPARE PARTS

Only use **original JDN spare parts**. J.D. NEUHAUS GMBH & CO. KG accepts no liability for the use of non-original components and/or modifications by unauthorised persons.

MOTOR LUBRICATION / OPERATION WITH SERVICE UNIT

JDN Air Hoists are provided with motor lubrication which must be renewed as required, but every 5 years at the latest.

Therefore, the service unit for filtration and pressure-regulation of the compressed air can be installed without an oiler. If required, the service unit is also available with an oiler. Synthetic lubricants must not be used when operating with a service unit.

If the JDN Air Hoist is to be converted from operation with oiler to operation without oiler, the motor lubrication must be renewed after the oiler is taken out of operation. (see **Motor lubrication**, page 51)

Alcohols are not permitted for use as anti-icing agents.

CE DESIGNATION / INSTALLATION DECLARATION

Only hoists for which EC conformity in accordance with EC Machinery Directive 2006/42/EC has been declared may be operated within the EU.

In the case of a **CE** designation, only the EC conformity declaration provides information on which EC directive has been fulfilled.



APPLICATION

AREA OF APPLICATION

For permanent stationary outdoor operation, hoists must be protected against weathering and the maintenance intervals must be shortened.

ATTACHMENT POINTS



DANGER!

The attachment points for JDN Air Hoists must be designed to safely withstand the expected forces. Ensure that your JDN Air Hoist is capable of alignment under load, otherwise inadmissible additional stresses may occur.



DANGER!

The supporting structure of the air hoist must form a rigid mounting. Vibration damages the chain and can lead to chain fracture. Furthermore, external vibration must on no account be transmitted to the hoist (e.g. by the suspended load).

ENERGY REQUIREMENTS

For air pressure, air quantity and connections, see the table **Technical data**, page 65ff.

Air pressure specifications

One of the ways in which JDN Air Hoists are identified is by the nominal pressure (overpressure) indicated on the device. The nominal pressure specification is intended to indicate a system pressure (main air supply) of the same magnitude.

The system pressure of the main air supply applies to a connected air hoist provided that it is not switched on. After switching on, the system pressure drops to the actual pressure. The actual pressure (operating pressure) changes, depending on the size of the load as well as on the direction of the movement of the load (lifting and lowering).

In addition, the actual pressure depends on the cross-section and length of the hose.

For this reason, when calculating the performance of the air hoist, we have allowed for a 10% drop in nominal pressure when lifting the maximum load specified for the hoist.

Specifically: An air hoist designed for 6 bar achieves the specified performance values at an actual pressure of 5.4 bar.



DANGER!

There is a risk of overloading when working with system pressures exceeding 6 bar. The pressure must therefore be limited to 6 bar.

JDN Air Hoists must be operated with a sufficiently clean and dry air supply (it may be necessary to install an upstream air dryer to meet these requirements).

Do not operate JDN Air Hoists with other gases (if necessary, check with the manufacturer).

The air supply must fulfil the relevant quality requirements (see **Operating conditions**, page 17).

If, as an alternative, the motor is lubricated by means of the air supply, the following quantities of lubrication oil are required:

Oil content:

- ▶ 10 mg per m³ air consumption.

The oiler, integrated in the upstream service unit in this case, provides the required oil content in the air supply (see **Service unit**, page 48).

When ambient temperatures at the operating site are at or below 0°C and when the hoist is operated for longer periods (e.g. several minutes) ensure that the air supply is not too moist, otherwise there is a risk that the air lines, control valve, motor and brakes will ice up.

You can prevent icing by installing an upstream air dryer. It may be sufficient to feed lubricating oil with anti-icing additive (see **Lubricants**, page 28) into the air supply (see **Service unit**, page 48).



J.D. NEUHAUS
powered by air!

SAFE TRANSPORTATION

If you wish to transport your JDN Air Hoist to another site, please observe the following points:

- ▶ Carefully dismount trolley (if fitted).
- ▶ Set the entire hoist down carefully; do not allow it to drop. See **Technical data**, page 65ff.
- ▶ Lay control and supply hoses together in such a way that they are not kinked.
- ▶ Please ensure that the controls are not damaged. Risk of malfunction.
- ▶ Draw in the hoist chain in such a way that loops cannot form and the chain cannot become twisted.
- ▶ Secure the chain.

STORAGE CONDITIONS

BREAKS IN OPERATION

- ▶ In the case of longer operational breaks, coat the chain and hook with a light film of oil.
- ▶ Motor conservation
- ▶ If the motor lubrication is not renewed after the specified intervals, the motor must be conserved. For this purpose, use a non-resinous and non-sticky conserving oil with a conserving protection duration which corresponds to the length of the planned operational break.

STORAGE

- ▶ Close off the air supply hose connection using adhesive tape or a suitable cap in order to prevent dirt ingress.
- ▶ Protect the air supply hose from damage.
- ▶ Store your JDN Air Hoist in a clean and dry place.



INITIAL OPERATION

UNPACKING



CAUTION!

When unpacking, take account of the weight of the hoist. See Technical data, page 65ff.



ATTENTION!

Do not bend the control lines. Kinked control lines can result in malfunctions.

Keep the accompanying documents in the place provided, near the operating site.

Lift the hoist carefully out of the packaging.

Dispose of packaging in the local recycling system.

ASSEMBLY

JDN Air Hoists are usually delivered pre-assembled.

If not, first read the following sections:

- ▶ Connecting the controls, page 24
- ▶ Drawing in the chain, page 36
- ▶ Chain box, page 64

In the event that the chain is included unattached, a short auxiliary chain is drawn into the hoist. In order to draw in the chain, the hoist must be connected to the main air supply and must be ready for operation.

PRIOR TO INITIAL OPERATION, THE CHAIN MUST BE LUBRICATED (SEE LUBRICATING THE CHAIN SECTION, PAGE 46).

INSTALLING THE HOIST



DANGER!

JDN Air Hoists must only be installed by qualified personnel. Faulty installation can lead to serious accidents.



DANGER!

The attachment points for JDN Air Hoists must be able to safely withstand the expected forces.



DANGER!

The supporting structure of the air hoist must form a rigid mounting. Vibration damages the chain and can lead to chain fracture. Furthermore, external vibration must on no account be transmitted to the hoist (lifting gear). (e.g. from the suspended load).

- ▶ Provide a suitable working platform.
- ▶ Attach the hoist at the suspension hook (or suspension eye), to the running gear or a stationary fixing.
- ▶ Ensure that the hook safety catch closes automatically.

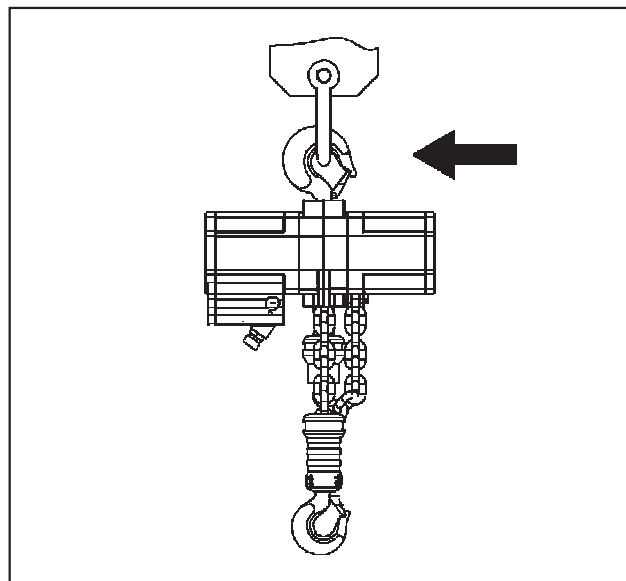

Secure attachment of the hoist at the suspension hook or suspension eye



DANGER!

When loads are taken up suddenly on slack chain, especially using hoists with high lifting speeds, forces are generated which may be equivalent to several times the load weight.

Type	Force
PROFI 25 TI	1.4-times load-carrying capacity
PROFI 37 TI	1.3-times load-carrying capacity
PROFI 50TI	1.25-times load-carrying capacity



CONTROLS

JDN Air Hoists are actuated via the following controls:

Controls	Sensitive		Emergency-stop button	
	yes	no	yes	no
E control		x	x	
F control	x	x	x	
Rope control	x			x

The actuating elements (pushbuttons, levers) return to the zero position automatically after being released.

The EMERGENCY-STOP function is activated by pressing the EMERGENCY-STOP button. Once the button has been pressed, all the other control elements are disabled. The movement of the load hook is also stopped.

The function is reset by simply releasing the EMERGENCY-STOP button.



E control



F control

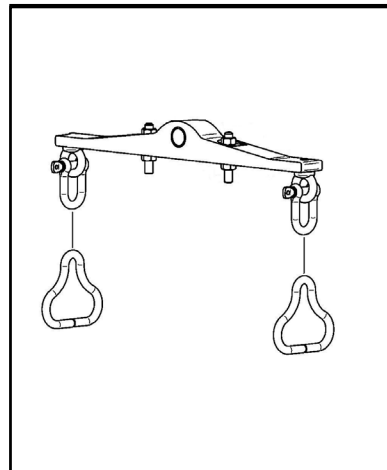

Rope control



CONNECTING THE CONTROLS

CONNECTING THE ROPE CONTROLS

The control ropes are designed as knotted link chains.

- ▶ Fasten both knotted link chains at the ends of the control lever using shackles and eyebolts.
- ▶ Cut the knotted link chain to the required length.
- ▶ Fasten one handle to the free end of either knotted link chain. The green handle is intended for the "lifting" function and the yellow one for the "lowering" function. Ensure that the handles are attached to the correct chains during installation.

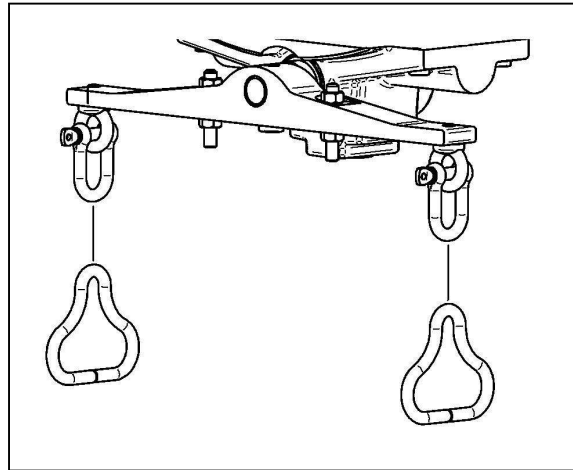

Installed rope controls



CONNECTING THE AIR CONTROLS

FASTENING THE COMPLETE CONTROL UNIT TO THE HOIST

F control:

- First fasten the hose carrier. For this purpose, unscrew the hexagon bolt and attach the hose carrier.

CONNECTING THE CONTROL HOSES

To help guide you, short sections of hose in colours corresponding to the hoses to be connected have been inserted in the connections in the factory.

You can connect the hoses one after another.

REMOVING THE HOSE PIECES

- Press down the locking ring **1** with a suitable tool (for example a screwdriver), pulling out the hose piece **2** at the same time.

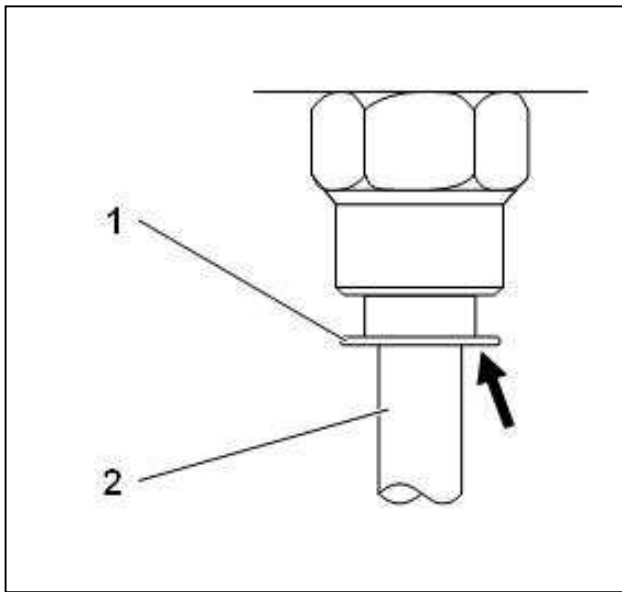

Detaching connections

MAKING CONNECTIONS



ATTENTION!

Please ensure that the hose is not bent when inserted.

- Put the end of the corresponding hose into the bore of the corresponding plug-in connection.
- Push the hose in as far as possible, ensuring that the hose is not bent when inserted.
- Check the connection by pulling on the hose.

If air escapes from the connection while operating the hoist, try to push the affected hose even further in.

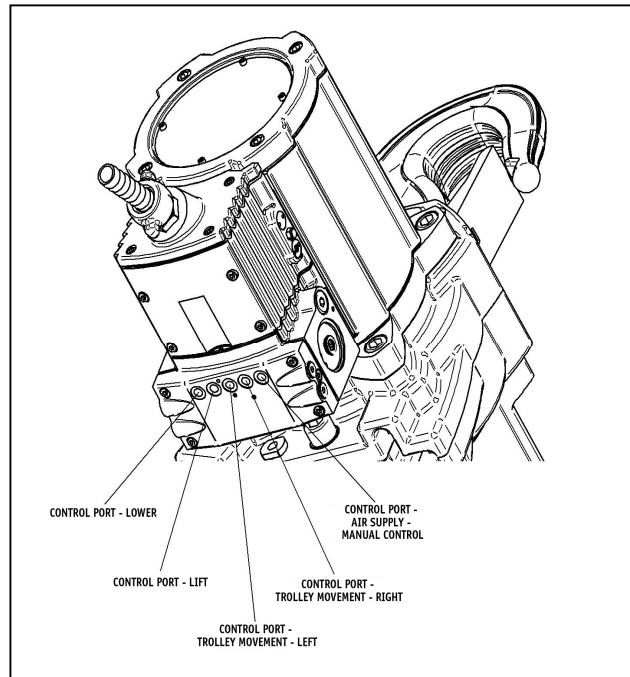

Motor side with air hoist connecting plate



ATTACHING STRAIN RELIEF

E and F controls:

- ▶ Insert the loop of the strain relief (wire rope) in the eyebolt provided.

E-CONTROL CONNECTION

Pushbutton valve (hand control)

- ▶ Guide the strain-relief rope through the eye on the pushbutton valve and secure it using the cable clamp.
- ▶ Push the one-ear clamps onto the hose ends.
- ▶ Attach the hoses to the hose nipples.
- ▶ The one-ear hose clamp must lie in the middle of the hose nipple clamping range. The best clamping characteristics are achieved in this range.

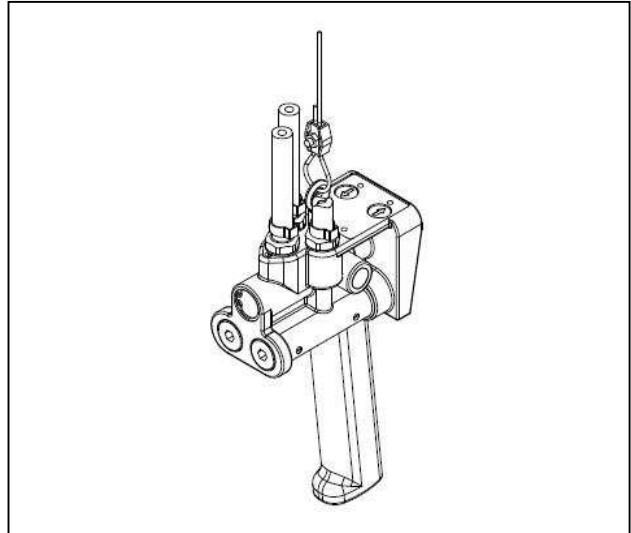

E CONTROL with strain relief



CONNECTING TO THE MAIN AIR SUPPLY

- ▶ Check the air connection for contamination and clean if necessary.
- ▶ Blow through the compressed air hose in order to remove foreign bodies.
- ▶ Attach the compressed air hose to the connection on the hoist. Secure using a hose clamp to prevent detaching.
- ▶ Tighten the union nut.

Attach the connection and securely fasten the union nut.

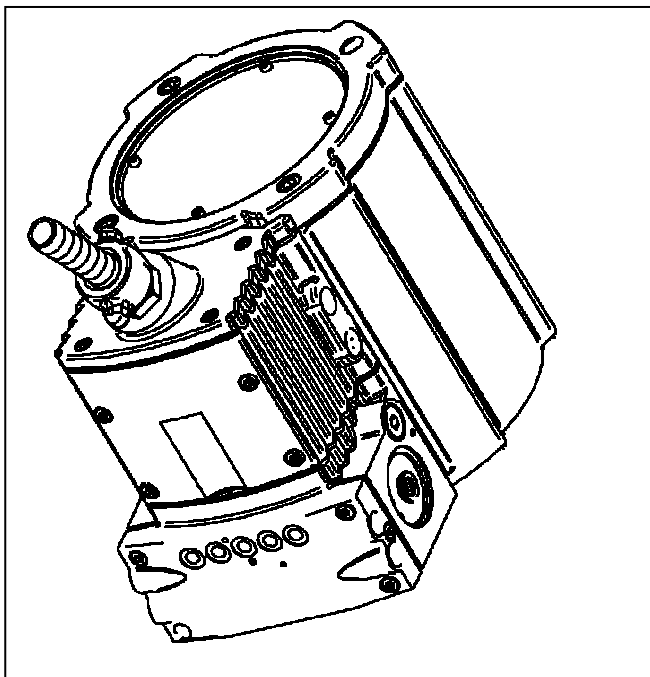

LUBRICANTS

The following lubricants are intended for normal environmental influences.

If operating under adverse conditions that induce increased wear, consult J.D. NEUHAUS, for further information.



CAUTION!

Oil and grease can cause skin irritation.
Wear protective gloves at all times.



ATTENTION!

Potential damage! Do not mix synthetic oils or greases with mineral oils, as the properties may be impaired.

In addition, never mix different types of lubricating grease within the synthetic or mineral lubricant groups.

Synthetic lubricants must not be used when operating with oilers. Alcohols are not permitted for use as anti-icing agents.

Application	Lubricant
Motor lubrication - at factory - for operation with oiler	- JDN high-performance grease, Part No. 11901 (250 ml) - Air motor oil type "D", kinematic viscosity approx. 30 mm ² /s (cSt) at 40°C, anti-icing additive if required
Chain lubrication	Chain oil or motor vehicle engine oil, kinematic viscosity approx. 150 mm ² /s (cSt) at 40°C, or special lubricant from J.D. NEUHAUS In areas with very high corrosion potential, e.g. offshore, a lubricant with especially high-performance anti-corrosion properties must be used.
Motor conservation (not applicable when using JDN high-performance grease)	Non-resinous protective oil rated for the duration of the storage period
Motor cleaning (not applicable when using JDN high-performance grease)	Pure petroleum
Lubrication of bearings and gearboxes (also for exposed gears)	Saponified lithium grease, felting penetration 265-295 (0.1 mm), ground oil viscosity: 190 cSt (mm ² /s) at 40°C, dripping point: 180°C, operating temperatures: 0°C to + 120°C, designation according to DIN 51825: KP2K-20 Active agents: EP additives (for wear-reduction) and ageing protection; water resistant and corrosion protection

A copy of the special publication "Recommended lubricants" is available on request.



APPENDIX

TECHNICAL DATA

Type		25 TI	37 TI	50 TI
Load-bearing capacity	t	25	37.5	50
Number of chain sections		2	3	4
Air pressure	bar	6		
Lifting speed at nominal load	m/min	1.25	0.75	0.55
Lifting speed without load	m/min	2.4	1.7	1.3
Lowering speed at nominal load	m/min	2.8	2.0	1.6
Air consumption at nominal load, lifting	m ³ /min	6.5		
Air consumption at nominal load, lowering	m ³ /min	2.9		
Air connection		G 1 ½		
Hose size (∅ inside/ ∅ outside)	mm	35 / 51		
Weight for standard lift / rope control	kg	550	850	940
Chain dimensions	mm	23.5 x 66		
Weight for 1m chain	kg	12.2		
Standard lift	m	3		
Control length for standard lift	m	2		
Noise pressure level with nominal load with standard silencer - lifting ¹⁾	dB (A)	78		
Noise pressure level with nominal load with standard silencer - lowering ¹⁾	dB (A)	82		

¹⁾ measured from 1 m distance according to DIN 45635 Part 20



OPERATION

RULES FOR THE SAFE OPERATION OF HOISTS

As a hoist operator, you are responsible for your own safety and that of your colleagues in the working area of the hoist.

- ▶ Hoists may only be operated by persons charged with this task by their company.
- ▶ Before using the JDN Air Hoist for the first time, familiarise yourself with all permissible operating conditions. For this purpose, read these operation instructions thoroughly and carry out the described actions on the hoist, step by step.
- ▶ Immediately report any malfunctions to your safety officer, so that the fault can be remedied without delay.
- ▶ Adhere to the regulations of the accident prevention authorities (e.g. Berufsgenossenschaft (trade association) regulations in Germany).
- ▶ Always comply with the information listed under **Intended use** on page 16.

The following are regarded as improper use:

- ▶ Changing load-carrying capacity depending on load position: JDN Air Hoists are not equipped with load-carrying capacity indicators, they may therefore only be used in those applications in which the load-carrying capacity does not change with the position of the load.
- ▶ Oblique pulling of loads in general.

Definition of oblique pulling

Oblique pulling is the deviation of the load chain and the chain hoist from the vertical position, for a force acting in a straight-line between the point of force application of the load on the load hook and the point of suspension on the supporting structure.



Oblique pulling

Under special safety provisions relevant to the particular situation, JDN Air Hoists may be used for oblique pulling (see **Intended use**, page 16).

In this case, a chain box must not be used, as the chain may fall out or become knotted. Oblique pulling is not permitted if hoists are installed in trolleys or running gear. Please contact us, if required.

- ▶ Breaking free or dragging of loads.
- ▶ Loading of the hook at the tip.
- ▶ Catching falling loads.
- ▶ Carrying persons (see **Intended use**, page 16).
- ▶ Jog control with a load on the hook.
- ▶ Switching to the opposite direction with a load in motion.
- ▶ Approaching lifting and lowering limiters during normal operation.
- ▶ Never hold the chain in the area of the centre section under tension at the upper or lower limit position of the load hook.



JDN Air Hoists must not be used for the following applications, for example:

- ▶ Critical areas of nuclear plants.
- ▶ Over acid baths or other plants with corrosive substances.
- ▶ In areas in which organic acids are present.

To ensure the safety of personnel and property when using JDN Air Hoists, it is essential that the following points are observed:

- ▶ Lift the load carefully at first.
- ▶ Never touch a running chain.
- ▶ Never use the hoist chain for attaching loads.
- ▶ Never allow loads to fall into the hoist chain.
- ▶ If the chain is slack, do not take up the load at maximum speed.
- ▶ Only use **original JDN chain boxes**.
- ▶ Do not exceed the permitted filling capacity of the chain box.
- ▶ When operating without a chain box, avoid hazards due to idle chain (falling, catching, impacting), see **Operation without chain box**, page 19.
- ▶ Never apply bending loads to chains.
- ▶ Do not join or repair chains.
- ▶ Do not work with a chain that is drawn tight, bent or extended.
- ▶ Check blocked chains for damage.
- ▶ Straighten twisted chains (defective bottom block)
- ▶ Do not work with a damaged, worn or rusty chain.
- ▶ Permitted operating temperature for chain and hook: -20°C to $+150^{\circ}\text{C}$, permissible ambient temperature: -20°C to $+70^{\circ}\text{C}$, permitted heat absorption of hoist body: max. 90°C .
- ▶ Never allow persons to enter the area below the suspended load.
- ▶ Never attempt to remedy a fault while a load is suspended.
- ▶ Only use suitable and approved sling gear; do not jam the hook at the point of attachment.
- ▶ Ensure that the operator is not put at risk within the operating area by sling gear or the load.
- ▶ Follow the relevant instructions for attaching loads.
- ▶ Before attaching the load, accurately position it vertically below the hoist. The chain must hang vertically before lifting.
- ▶ Ensure that the hook safety catch is closed.
- ▶ Repair damaged hook safety catches.
- ▶ Before lifting loads, ensure that the maximum permitted load is not exceeded! Sling gear must be included in the weight of the load.
- ▶ During lifting and lowering, prevent accidents by ensuring that the load remains stable and does not tilt or fall.
- ▶ Never force jammed loads.
- ▶ Only lift one load at a time; never several loads simultaneously.
- ▶ Never lock the control elements of the control devices.
- ▶ If the control elements become difficult to operate, have the hoist repaired.
- ▶ In the case of power failure, secure the load and the surrounding area until the power is restored.
- ▶ Never use or repair bent, open or deformed load hooks. The hoist must be expertly repaired and the hook replaced.
- ▶ Never anneal the hook.
- ▶ Only operate JDN Air Hoists with original JDN controls.
- ▶ Uncontrolled, external force factors (e.g. due to hydraulic cylinders, falling loads) are not permitted.
- ▶ Repair stiff hook bearings.
- ▶ Do not kink or pinch control hoses.
- ▶ Have loosened bolted connections tightened by the Repairs department.
- ▶ Before removing compressed air hoses, shut off the compressed air supply.
- ▶ If the braking distance is excessive, repair the hoist.
- ▶ If a load is lifted using several air hoists, prevent overloading due to incorrect weight distribution.
- ▶ Select a safe operating location.
- ▶ Ensure the system pressure is correct.
- ▶ Never touch metallic hand controls that are colder than 0°C or hotter than 43°C without suitable protective gloves.
- ▶ Do not make modifications to the hoist.
- ▶ Only use original JDN spare parts. J.D. Neuhaus GmbH & Co. KG accepts no liability for the use of non-original components and/or modifications by unauthorised persons.



- ▶ If, in the case of multi-chain hoists, the bottom block is lying on the floor, move it back to a hanging position in a controlled manner (evenly-loaded chains).
- ▶ Special safety precautions must be taken when loads are being hoisted into areas that are out of sight.



DANGER!

For all air hoist applications, ensure that the load hook can be lowered all the way to the ground, in order to prevent a load being moved to the lower limit position, without reaching the ground. Danger due to overloading!



DANGER!

Never use hoists lying on the ground if they are not specifically intended for horizontal pulling.



DANGER!

The fatigue strength of chains is significantly impaired due to extreme corrosion (pitting corrosion). **Risk of fracture.** Hydrogen-induced embrittlement with resultant stress cracks due to highly corrosive media (e.g. sea water) may affect high-strength steels (e.g. chains). Risk of fracture! This process is encouraged by so-called recombination poisons. Examples of these are hydrogen sulphide, cyanide, arsenic compounds and rhodanide. If rusty chains are not replaced for operational reasons, they must be inspected for cracks at intervals of three months.

Company operating instructions

Where hoists are to be employed under particularly difficult conditions, the company must provide operating instructions in easily comprehensible form, in the language of the operator, based on these operation instructions. Here, measures for safe operation are stipulated in accordance with prevailing operating conditions.

Furthermore, it is essential that all the regulations set out in the sections **Intended use**, page 16 and **Operating conditions**, page 17, are observed.



CONTROLS

JDN Air Hoists can be equipped with a variety of control devices. They are all suitable for use in explosion-hazardous areas.

All control switches return to the zero position when released.

CONTROL VALVE ON MOTOR

Air control (E, F, FI controls) with main-stream control valve with integrated main-stream valve

The control valve consists of:

1. Main-stream valve
2. Direction control valve as slider with sleeve

The main-stream valve lies upstream of the direction control valve. If no control pressure is present, this valve is closed and the direction control valve is depressurised. If control pressure is applied from the hand control, the valve opens and releases the main stream.

If the red EMERGENCY STOP button on the hand control is pressed, all control lines are depressurised and the main-stream valve is closed.

Rope control

Control valve with upstream main-stream valve. The main-stream valve is opened via upstream valves when the rope control is actuated.

The control valve consists of:

1. Main-stream valve
2. Direction control valve as slider with sleeve
3. Positioner

The direction control valve positioner (slider with sleeve) is mechanically connected to the control lever directly via the control shaft.

No separate EMERGENCY STOP button is therefore required.

E-CONTROL

With E-control, lifting and lowering movements can be controlled via two pushbuttons.

The direction of movement of the load hook is marked on the upper side of the valve housing, above the pushbuttons.

- ▶ Lifting: Press the right pushbutton.
- ▶ Lowering: Press the left pushbutton.

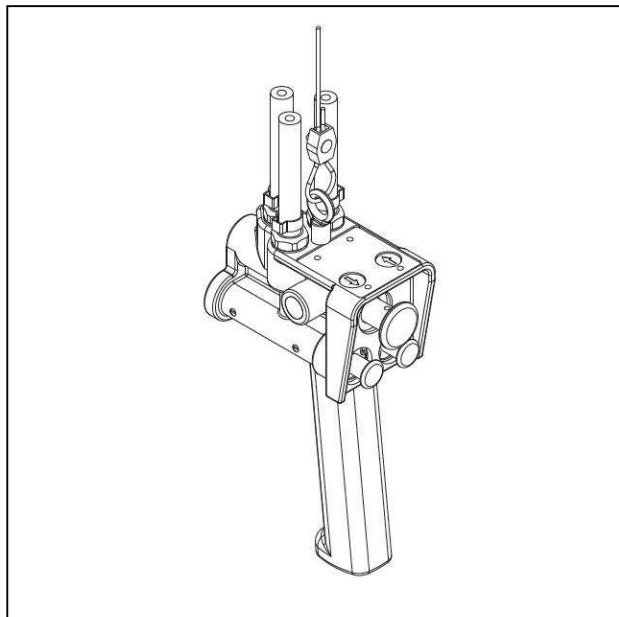

E-control with EMERGENCY STOP button



PUSHBUTTON F-CONTROL

With pushbutton F-control, lifting and lowering movements can be controlled via two pushbuttons. The direction of movement of the load hook is marked by arrows next to the pushbuttons.

- ▶ Lifting: Press the upper pushbutton.
- ▶ Lowering: Press the lower pushbutton.

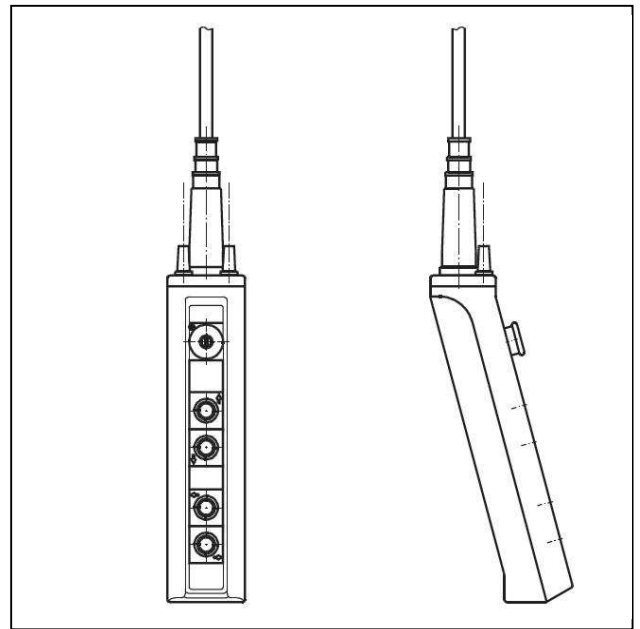

F-control with EMERGENCY STOP button



EMERGENCY STOP DEVICE

These controls are always equipped with an EMERGENCY STOP device.

In order to avert danger produced by the lifting movement as quickly as possible, release the pushbuttons - the movement of the load is then interrupted immediately.

Only press the red EMERGENCY STOP button firmly if this Stop function fails. The EMERGENCY STOP button engages. This closes the separate main-stream valve and the load hook comes to a stop instantaneously. The pushbuttons for lifting and lowering now no longer function.

The EMERGENCY STOP button can be released again by turning clockwise. It returns automatically to its initial position.



DANGER!

Never release the EMERGENCY STOP button before the danger has been eliminated and the stop function via the pushbuttons has been restored.

ROPE CONTROL

With rope control, the lifting and lowering movements are controlled directly. Both rope ends are connected via a handle, enabling sensitive control.

The control elements for rope control and the energy-switching component of the control valve on the motor (reversing valve) are positively connected to one another. This connection is designed in such a way that, in an emergency, the control valve can be reset to a stable neutral position. The main-stream valve is closed simultaneously. No additional EMERGENCY STOP device is required.

- ▶ Lifting: Carefully pull on the chain with the green handle. The load is lifted slowly.
- ▶ Pull harder on the chain in order to increase the lifting speed.
- ▶ Release the chain slightly in order to reduce the lifting speed.
- ▶ Lowering: Carefully pull on the chain with the yellow handle. The load is lowered slowly.
- ▶ Pull harder on the chain in order to increase the lowering speed.
- ▶ Release the chain slightly in order to reduce the lowering speed.

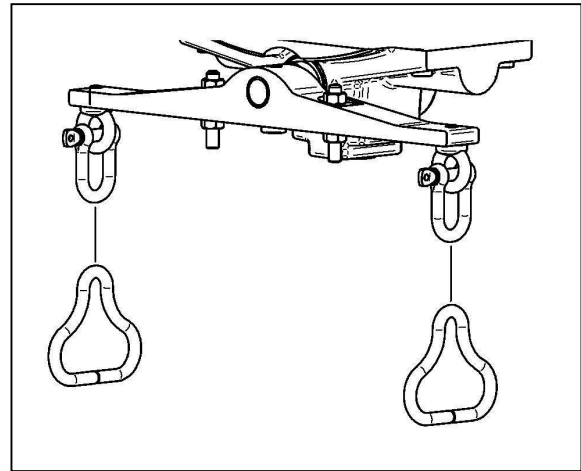

Rope control

OVERLOAD PROTECTION

The overload protection limits the operating pressure of the compressed air supplied. It responds as a function of load and is set to a limit value of approx. 125% of the nominal load. The force limiting factor then has a value of 1.25.

When the overload protection is activated, lifting is only possible again once the lowering movement has been switched (unloading the hoist).

The overload protection may also respond when moving at full unloaded speed against a load to be lifted, even when it is below the load size set. We therefore recommend tensioning the slack chain before lifting the load.

For checking and adjusting the overload protection, see **Checking and adjusting overload protection**, page 61.

LOAD HOOK MOUNT

With standard version JDN Air Hoists, the load hook can only be turned around its longitudinal axis when it is unladen, as the hook mount in the housing is not equipped with antifriction bearings.



CHAIN**RUNNING-IN INSTRUCTIONS FOR HOIST CHAINS PRIOR TO OVERLOAD TESTING****ATTENTION!**

If these instructions are ignored, you will damage the high-quality chain in your hoist/winch during testing, before initial use. In this respect, the manufacturer accepts no liability.

Hoist chains with a load-bearing capacity in excess of 25 t must be run in prior to the overload test, in order to ensure that the surface pressure at the contact points of the chain links (in the joints) can be withstood.

In preparation for overload testing, the following pre-conditions must be fulfilled:

1. The joints of the chain must be thoroughly lubricated. Observe the operation instructions.
2. The chain must be run in by raising and lowering it five times with approximately 50% of the nominal load-bearing capacity. This will increase the load-bearing capacity of the joints sufficiently.
3. In particular, the section of the chain to be tested with the excess load must be thoroughly lubricated once again.

Only then can the overload test be performed.

**DANGER!**

The fatigue strength of chains is significantly impaired due to extreme corrosion (pitting corrosion). **Risk of fracture.**

Hydrogen-induced embrittlement with resultant stress cracks due to highly corrosive media (e.g. sea water) may affect high-strength steels (e.g. chains). **Risk of fracture!**

This process is encouraged by so-called recombination poisons. Examples of these are hydrogen sulphide, cyanide, arsenic compounds and rhodanide.

Furthermore, hazards arise due to rusty chains when using chain boxes, as the chain can drop out of the chain box if it forms a heap.

In addition, rusty chains are subject to extreme wear.

Protect the chain from corrosion.

Ensure that the chain is in perfect condition before initial operation of the JDN Air Hoist.

- ▶ Straighten the chain if it is twisted.
- ▶ Please ensure that the chain can always run straight in order to prevent it from blocking before the chain infed at the centre section.

The chain must be checked at regular intervals (see **Checking chain, chain sprocket and chain guides**, page 58).

If one of the following defects occurs:

- ▶ elongated chain links,
- ▶ bent chain links,
- ▶ externally damaged chain links,
- ▶ chain drawn tight,
- ▶ extreme wear in the joints,
- ▶ corrosion pitting,

the JDN Air Hoist must be sent for repair immediately (see also **Check dimensions**, page 58).

The chain must be lubricated with the load removed (see **Lubricating the chain**, page 46).

For suitable lubricants see **Lubricants**, page 28.

The lubricating intervals are dependent upon the daily running time.

Increased chain wear may occur if it is subject to wear-promoting environmental influences.

- ▶ Shorten the inspection intervals

Please note that for safety reasons the hoist chain

- ▶ may not be used for fastening loads,
- ▶ may not be touched while running,
- ▶ may not be placed under bending strain, so that the chain links can be bent while being fed in,
- ▶ may not be repaired or connected to other hoist chains (e.g. with bolts, emergency links, etc.).

The permitted chain temperature range is -40°C to +150°C.

If you use a chain box, the permissible filling capacity may not be exceeded (see **Chain box**, page 64).



LOAD HOOK

Check the hook opening “a” and the height “h” of the load hook of JDN Air Hoists that are in use at least once a year (see **Check dimensions**, page 58ff).

- Load hooks should not
- ▶ be loaded at the tip,
 - ▶ be adjusted,
 - ▶ be annealed.

If the load hook is bent, the JDN Air Hoist must be sent for inspection.

The permitted load hook temperature range is -40°C to +150°C.

ATTACHING THE LOAD



DANGER!

Only use attaching cables or attaching chains which are suitable for the load. Attaching must not be attempted by winding with the lifting chain around the load.

In Germany, the trade association regulations “Operation of load carrying devices used with lifting equipment” (BGR 258) must be adhered to.

In other countries, the relevant local regulations must be observed.

- ▶ Attaching aids must be attached at the lowest point of the hook. Never load the tip of the hook.
- ▶ Ensure that the hook safety catch is closed.

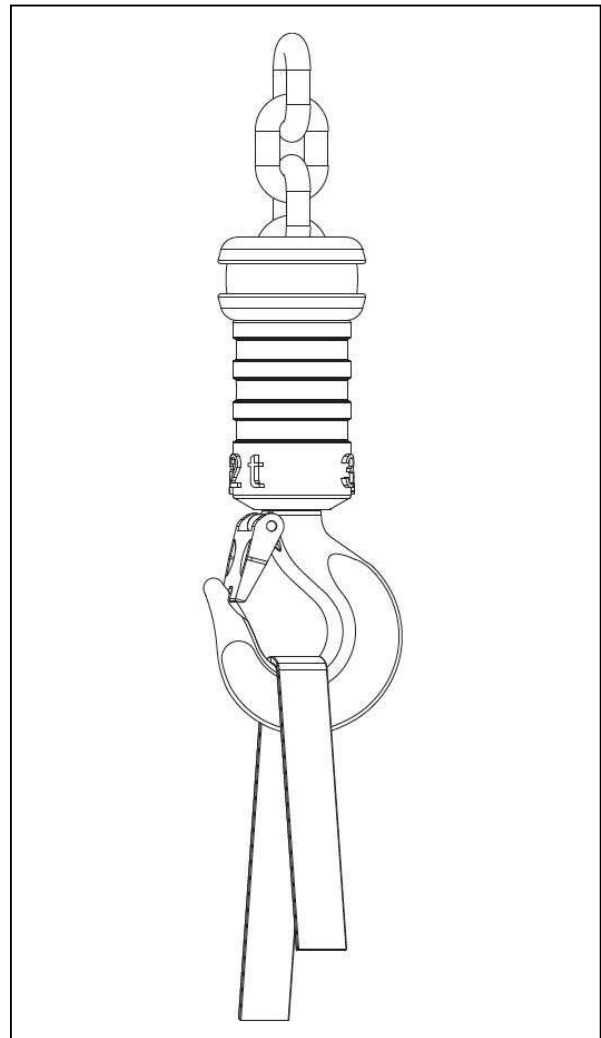

Secure load attachment



LIFTING THE LOAD



ATTENTION!

JDN Air Hoists must be capable of alignment under load. Otherwise impermissible additional forces can occur, which can damage the hoist components.

- ▶ First, lift the load hook to tighten the slack chain. With the chain tight, briefly interrupt the lifting procedure. The hoist can align itself and the material is protected.
- ▶ Then lift the load.

The overload protection system aborts the lifting operation in the event of loads whose weight is more than the pre-defined limit value for the overload protection (see **Overload protection**, page 35 and **Checking and adjusting overload protection**, page 61).

LOWERING THE LOAD



DANGER!

Ensure that there are no persons below the load.

- ▶ Then lower the load and set it down carefully.



DANGER!

For all air hoist applications, ensure that the load hook can be lowered all the way to the ground, in order to prevent a load being moved to the lower limit position without reaching the ground. Danger due to overloading!

DETACHING THE LOAD

- ▶ Lower the load hook far enough, so that the load can be easily detached.
- ▶ Move the load hook out of the lifting area, in order to avoid hazardous situations.

INTERRUPTING WORKING

If you wish to interrupt working with your JDN Air Hoist:

- ▶ Set down and detach the load.
- ▶ Move the load hook out of the lifting area in order to avoid hazardous situations



SHUTTING DOWN

If the hoist is to be taken out of operation for a longer period of time, it must be protected against corrosion and dirt.

- ▶ Coat the chain and hook with a light film of oil.
- ▶ To avoid hazardous situations, move the load hook out of the lifting area.
- ▶ Do not move against the lifting and lowering limiters/buffers (emergency end-stop devices).
- ▶ Depressurise the air line.

STORAGE

See section **Storage conditions**, page 21.

DISMANTLING



RISK OF INJURY!

JDN Air Hoists must only be dismantled by qualified personnel.

- ▶ Depressurise the air line.
- ▶ Provide a suitable working platform.
- ▶ Loosen the union nut and remove the air hose.
- ▶ Protect the air connection against dirt ingress.
- ▶ Mark the connections.
- ▶ Detach the control hoses from the hoist. Do not bend the control hoses.
- ▶ Detach the strain relief and hose carrier and remove the control device.
- ▶ Carefully detach/dismount the hoist and remove.
- ▶ In the case of trolleys, proceed in reverse order as described in the section on mounting trolleys (in the trolley operation instructions).

DISPOSAL

JDN Hoists contain a range of materials which, on expiry of the service life, must be disposed of or recycled where appropriate, in accordance with statutory regulations.

Please note the following list of materials used:

HOIST

- ▶ Ferrous materials
 - Steel
 - Nodular cast iron
- ▶ Non-ferrous metals
 - Bronze
 - Aluminium
- ▶ Plastics
 - Polyethylene
 - Polyurethane
 - Polyoxymethylene
 - Polyvinyl chloride
 - Polyamide, glass-fibre reinforced
 - Natural rubber
 - Epoxy resin
 - Polyacetal
 - Polypropylene
 - Phenol resin
 - Thermoset moulding compound (Asbestos-free brake lining)
 - Polyester
 - Synthetic rubber
 - Wool felt

FILTER SILENCER / SERVICE UNIT:

- Diecast zinc
- Brass
- Nitrile rubber
- Aluminium
- Polypropylene
- Polyurethane
- Glass-fibre reinforced plastic
- Steel
- Polyacetal
- Polyethylene



MAINTENANCE

MAINTENANCE AND INSPECTION INTERVALS

JDN Air Hoists are extremely robust and require little maintenance. Compliance with maintenance and inspection intervals is of great importance in order that the hoist operates safely and reliably over a period of many years.



CAUTION!

Maintenance work on JDN Air Hoists must only be performed by trained and qualified personnel.

CLEANING AND CARE

If your JDN Air Hoist is often used at different locations, particularly in dirty and damp environments,

- ▶ clean any dirt off the hoist and the chain,
- ▶ seal off the air supply connections,
- ▶ protect the hoist and, in particular, the chain from corrosion,
- ▶ store the hoist in a clean, dry place.

SPARE PARTS

If, during repair work, the replacement of components is necessary, **only original JDN spare parts** may be installed.

LUBRICANTS

See section **Lubricants**, page 28.

INSPECTION AND REPAIRS

Series lifting equipment is classified into groups and dimensioned according to the type of operation (Driving mechanism classification according to ISO/FEM). The average daily operating time and the load spectrum determine the classification. This is assuming that the lifting and lowering paths are approximately the same.

For devices used mainly in lowering operation (from 75% of on-time), the theoretical operating time is reduced due to the higher lowering speed in the range from 50% to 100% of the nominal load.

Therefore, the determined portion of the theoretical operating time must be multiplied by a factor of f_v .

The factor f_v has a value of 1 to 50% of the nominal load, increasing linearly to 1.5 at 100% of the nominal load (nominal load percentage P).

$$f_v = 1 + 0.5 \frac{P - 50}{50} \quad (\text{for } P > 50\%)$$

In order to achieve safe operating periods, the company must check that the theoretical operating time has been achieved during each inspection, by the person responsible. This must be documented in the inspection log at least once annually. The inspection log is only required in the Federal Republic of Germany. Please contact us if you require an inspection log.

Instructions and a model for determining the actual operating time can be found from page 42 onwards.

When the theoretical operating time has been reached, a general overhaul must be performed. Detailed explanations for the determination of the actual operating time and its documentation can be found in the national safety regulations. Alternatively, the calculation model in these operation instructions can be used. The general overhaul must be initiated by the operator and must be documented in the inspection log. Information on general overhaul can be requested from the manufacturer.



Only if the group classification corresponds to the actual mode of operation of the lifting equipment, does a safe operating period conform to the theoretical operating time. Deviations of the actual mode of operation from that used for calculation extend or shorten the safe operating period.

For all inspection work which is not a part of the daily inspection, suitable access must be made to the hoist. The hoist must be disconnected from the main air supply during assembly work.

Dismantling the hoist, see page 39.



CAUTION!

Following each repair, the hoist must be checked for operational readiness.



INSTRUCTIONS CONCERNING THE "MODEL FOR DETERMINING THE ACTUAL OPERATING TIME"

The decisive factors for the mode of operation are the collective loads with different cubic averages "k".

The load spectrum indicates to what extent a driving mechanism, or part of one, is subjected to its maximum stress or whether it is only subjected to lower stresses. The cubic average (factor of the load spectrum) is calculated using the following formula.

$$k = \sqrt[3]{(\beta_1 + \gamma)^3 \cdot t_1 + (\beta_2 + \gamma)^3 \cdot t_2 + \dots + \gamma^3 \cdot t_\Delta}$$

Definitions:

$$\beta = \frac{\text{Maximum or ultimate load}}{\text{Load bearing capacity}}$$

$$\gamma = \frac{\text{Dead load}}{\text{Load bearing capacity}}$$

$$k = \frac{\text{Op.time w. max. load or part. and dead load}}{\text{Total operating time}}$$

$$t_\Delta = \frac{\text{Op.time with dead load only}}{\text{Total operating time}}$$

The FEM* 9.511 rule differentiates between four load spectrums, which are identified by the definitions and by the ranges of the cubic averages k. This classification complies with ISO 4301/1.

*FEM = Federation Europeene de la Manutention
(European Federation of Materials Handling and Storage Equipment)

The formula given for the cubic average k does not take the weight of the harness into account. This is permissible if the ratio

$$\frac{\text{Weight of harness}}{\text{Load bearing capacity}} \leq 0.05 \text{ applies.}$$

To determine the mode of operation for calculating the partial operating times (actual operating time), the following load spectrum diagrams can also be used.

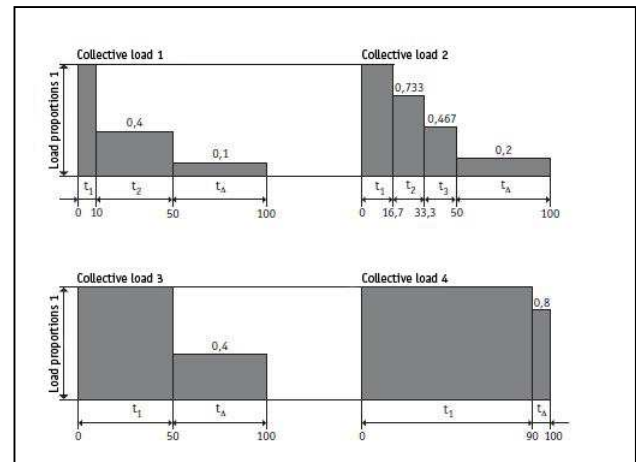

Load spectrum diagrams

Load spectrum		Definition	Cubic average	Load spectrum factor
1 (light)	L1	Driving mechanisms or parts thereof, which are only subject to the maximum stress in exceptional circumstances and are only subject to very low stresses continuously.	$k \leq 0.50$	$k_m = k^3 = 0.125$
2 (medium)	L2	Driving mechanisms or parts thereof, which are subject to the maximum stress fairly often and are only subject to low stresses continuously.	$0.50 < k \leq 0.63$	$k_m = k^3 = 0.25$
3 (heavy)	L3	Driving mechanisms or parts thereof, which are often subject to the maximum stress and are continuously subject to average stresses.	$0.63 < k \leq 0.80$	$k_m = k^3 = 0.5$
4 (very heavy)	L4	Driving mechanisms or parts thereof, which are regularly subject to the maximum stress of adjacent stresses.	$0.80 < k \leq 1.00$	$k_m = k^3 = 1$



J.D. NEUHAUS
powered by air!

MODEL FOR DETERMINING THE ACTUAL OPERATING TIME

The following calculation compares the actual operating time with the theoretical operating time in load spectrum 4 (very heavy).

1	2	3				4	5	6	7
Deployment location:	Average daily operating time in hours	Load spectrum factor relative to load spectrum for type of operation				Partial deployment	Remaining theoretical use in load spectrum 4 (When zero has been reached a general overhaul must be performed)	Date Delivery Initial operation Inspections	Qualified inspector Signature
		L1 Low	L2 Average	L3 High	L4 Very heavy	Column 2 x Column 3 x Operating days x factor 1.2			
-	0	0.125	0.25	0.5	1	0	Existing driving mechanism group, see nameplate M2 (1Cm) 200 hours M3 (1Bm) 400 hours M4 (1Am) 800 hours M5 (2m) 1600 hours	Delivery date Initial operation	J.D. Neuhaus GmbH & Co.KG

CALCULATION MODEL (DRIVING MECHANISM CLASSIFICATION M3)

Slewing crane assembly site	1.5	0.25			1.5 x 0.25 x 250 x 1.2 = 113 hours	(400 - 113) 287 hours	2 August 2004	A.N. Other
-----------------------------	-----	------	--	--	------------------------------------	-----------------------	---------------	------------



The specified inspection intervals are valid for use in accordance with the classification (see driving mechanism classification on the nameplate). The service life is approx. 10 years if the device is used in accordance with its classification. If the hoist is used more intensively the intervals are to be shortened accordingly. The degree of use must be assessed using the **model for determining the actual operating time** (see page 43). All operating hours are translated into full load hours. The theoretical operating time and the interval hours are indicated in full load hours.

Maintenance measure	Interval	Comment
Check oil level for motor lubrication (when operating with optional oiler)	Daily	(Filling and adjusting oiler, page 49)
Lubricating the chain	As required	(Lubricating the chain, page 46)
Visually check the chain	Weekly	

Inspection measure	Interval	Comment
Check control device	Daily	(Checking controls, page 47)
Check the braking function	Daily	(Checking braking function, page 46)
Checking direction of movement	Daily	(Checking direction of movement, page 47)
Check lifting and lowering limiters (buffers) visually	Daily	Replace buffer immediately if damaged, otherwise replace every 5 years
Check EMERGENCY STOP function	Daily	
Check chain	Every 3 months	(Checking chain, chain sprocket and chain guides, page 58) In the event of wear-promoting operating conditions, reduce intervals between checks
Checking lifting and lowering limiters	Annually	(Checking lifting and lowering limiters, page 47)
Check brakes with load	Annually	Load must be braked reliably (Checking braking function, page 46)
Check all the bolted and pin connections	Annually	
Check load hook on the load and carrying side	Annually	(Check dimensions, page 57ff)
Check the motor, check, clean and grease the control valve (JDN high-performance grease)	Annually	Measure the lifting speed
Check the axial movement of the hooks and eyes	Annually	(Checking axial play, page 60)
Check the service unit ¹	Annually	(Service unit section, page 48)
Check the silencer for permeability	Annually	(Checking silencer for permeability, page 47)
Check overload protection	Annually	(Checking and adjusting overload protection, page 61)
Check compressed air connections for damage	Annually	

¹ if fitted



Inspection measure	Interval	Comment
Check sealing efficiency and function of control valve	Annually	
Check the state of the chain box ¹ including mounting	Annually	(Chain box, page 64)
Check for brake wear and motor vane wear	Every 200 hours, at least every 5 years	(Motor installation and inspection, page 50), replace motor vanes every 5 years
In off-shore areas and other similar corrosive environments, replace the chain regularly	Every 5 years	
Check gearbox and perform lubricant change	Every 5 years	
Check the rotor/pinion shaft connection and lubricate with gear grease	Every 5 years	
Check the chain sprocket bearings and lubricate if necessary	Every 5 years	
Check chain sprocket and chain guides	Whenever the chain is	(Check dimensions, page 58)
Renew grease lubrication of motor	When required, at least every 5 years	(Motor installation and inspection, page 50)

¹ if fitted



LUBRICATING THE CHAIN

The chain of the JDN Air Hoist must be lubricated in the links when not under load.

- ▶ Clean very dirty chains.
- ▶ Lay the chain in a suitable container.
- ▶ Spray the chain with special lubricant or motor vehicle engine oil.

If you wish to lubricate the hanging chain, ensure that the chain links are oiled at the points of contact. For this purpose, move the chain to and fro.

A high-performance lubricant in an aerosol can is available from JDN, which adheres well to the chain after the solvent has evaporated and does not drip off, Part No. 12066 (spray can 400 ml).

For operation in areas with high corrosion potential, e.g. in the offshore sector, the chain can be largely protected against corrosion by the use of special lubricants. These types of lubricants are characterised among other things by weathering resistance, water insolubility and good adhesion properties. Re-lubrication intervals must be stipulated in accordance with the loading.

Please contact us, if required.

CHECKING BRAKING FUNCTION

Check the function of the brake daily as follows:

- ▶ Switch the unloaded air hoist alternately between lifting and lowering modes.

When a control element is released, the chain must be seen not to run on.



DANGER!

If the chain runs on, do not use the hoist. The hoist must be repaired.

For physical reasons, the braking distance cannot have the value zero. However, for the purpose of this functional check, running on of the chain must not be perceptible.

When checking the braking function under nominal load, the following braking distances must not be exceeded:

BRAKING DISTANCES UNDER NOMINAL LOAD (LOAD-CARRYING CAPACITY) AFTER LOWERING HAS BEEN STOPPED

Type	25 TI	37 TI	50 TI
Rope control	10	7	5
All others			
Controls with hose lengths of 2m HOSE LINES	20	14	10

Dimensions in [mm]

If the control hoses are long, the braking distances will increase due to longer air evacuation times.



CHECK LIFTING AND LOWERING LIMITERS

- ▶ Move the unloaded load hook until just short of the upper and lower end positions.
- ▶ Stop immediately before reaching the end position and then carefully (by repeatedly pressing the control element) move to the end position.
- ▶ The movement of the chain must be stopped due to deformation of the buffer. For hoists with overload protection, the lifting movement is additionally limited by shutting off the motor.
- ▶ Following successful testing, the buffer must be unloaded.



DANGER!

If the buffer is damaged, do not use the hoist. The hoist must be repaired (replace the buffer).

CHECKING CONTROLS AND EMERGENCY STOP FUNCTION

All control elements of the controls must always be free-moving.

- ▶ Unload the JDN Air Hoist.
- ▶ Briefly actuate and release all control elements of the controls one after the other. The control elements must return to their initial positions immediately. The on and off function must operate without problem.
- ▶ Press the EMERGENCY STOP button. All movement of the hoist must stop. Actuating the control elements must not cause a lifting or lowering movement.
- ▶ Turn the EMERGENCY STOP button to reset it.



DANGER!

If a control element is stiff or remains in the actuated position, do not use the hoist. The control must be repaired.

The main air valve is opened with each actuation of the EMERGENCY STOP button. It shuts automatically when the EMERGENCY STOP button is pressed in.

CHECKING DIRECTION OF MOVEMENT

- ▶ Check that the direction of movement of the load hook corresponds to the direction indicated by the arrows on the control elements.

CHECKING SILENCER FOR PERMEABILITY

Irrespective of the stipulated inspection intervals, the silencer must be checked for permeability if the hoist does not achieve the specified lifting speed (see **Technical data**, page 65ff).

The test is performed by comparing the lifting speeds under nominal load, with and without the silencer. The speed with standard silencer or filter silencer must be at least 80% of the lifting speed without a silencer element.

In the event of lower values, the silencer elements must be cleaned or replaced.

For reasons of noise protection, the device must not be operated without the silencer.



SERVICE UNIT

ATTENTION!

If a hoist is operated with a service unit, this should not be mounted further than 5m away from the hoist.

On hoists from the PROFIL range, the service unit comprises a filter regulator and, where applicable, an oiler. Usually, an oiler is not required in the service unit, as the motor is provided with internal permanent lubrication.

CHECKING AND ADJUSTING THE FILTER REGULATOR

The filter regulator is set to a nominal pressure of 5.4 bar in the factory (nominal pressure with motor running). Should the manometer indicate a different value, please first check the accuracy of the manometer. If the manometer is found to be OK, re-adjust the filter regulator with the motor running and the maximum load. For correct adjustment, a pressure of at least 7 bar is required upstream of the service unit.

- ▶ Lift the regulator knob.
- ▶ Turn the regulator knob until the manometer indicates a pressure of 5.4 bar.
Clockwise: higher pressure Anti-clockwise: lower pressure.
- ▶ Lock the regulator knob by pressing it down.

Alternatively, the filter regulator can be set to a pressure of 6 bar in the absence of an air stream. This setting is only correct for a pressure of at least 7 bar upstream of the service unit.

- ▶ Depressurise the air line downstream of the service unit and close it again.
- ▶ Turn the regulator knob anti-clockwise, in order to release the adjusting spring.
- ▶ Turn the regulator knob until the manometer indicates a pressure of 6 bar.
Clockwise: higher pressure Anti-clockwise: lower pressure.
- ▶ Lock the regulator knob by pressing it down.

DRAINING CONDENSATE

The condensate in the container is automatically drained.

CLEANING THE FILTER ELEMENT



ATTENTION!

Do not use alcohol for cleaning the service unit. Alcohol can damage parts of service unit. Transparent components must only be cleaned using soap solution.

The filter element must be cleaned once annually. For this purpose, proceed as follows:

- ▶ Shut off the main air supply and carefully allow the residual pressure to dissipate.
- ▶ Unscrew the container by turning the union nut anti-clockwise.
- ▶ Unscrew the separating plate.
- ▶ Remove the filter element from the stay bolt.
- ▶ Clean the filter element using soap solution and blow through forcefully.
- ▶ Reinstall the clean filter element on the stay bolt and fasten the separating plate.
- ▶ Screw on the container by turning the union nut clockwise.

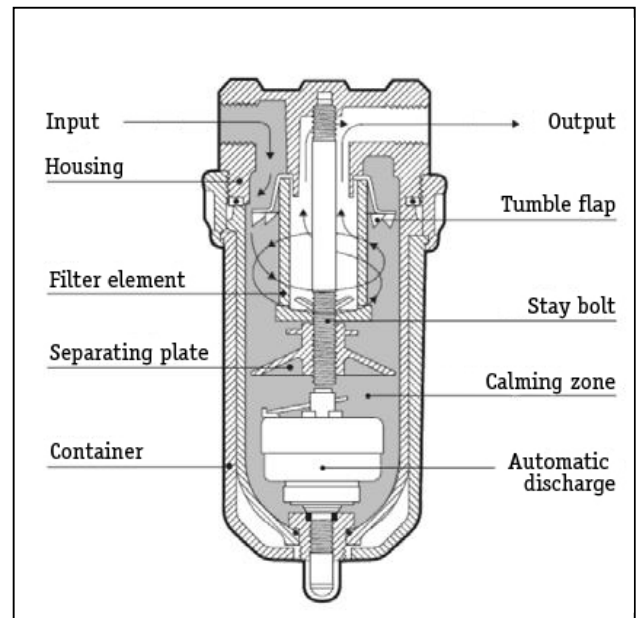

FILTER



FILLING AND ADJUSTING THE OILER

The oiler can also be filled under pressure.

- ▶ Check the oil level through the sight glass in the container.
The oil level must not fall below the minimum mark.
- ▶ Remove the oil filler screw.
- ▶ Fill the container with oil up to the maximum mark and refit the oil filler screw.
- ▶ Check the oil drop rate at the sight glass with the motor running.
- ▶ Turn the oil throttle screw using a screwdriver until the desired number of drops per minute is achieved. Turning clockwise reduces the amount of oil; turning anti-clockwise increases the amount of oil.

OIL DROP RATE (LIFTING WITHOUT LOAD)

For the Profi 25 – 50TI hoists, 15 drops per minute should be set.
OILER

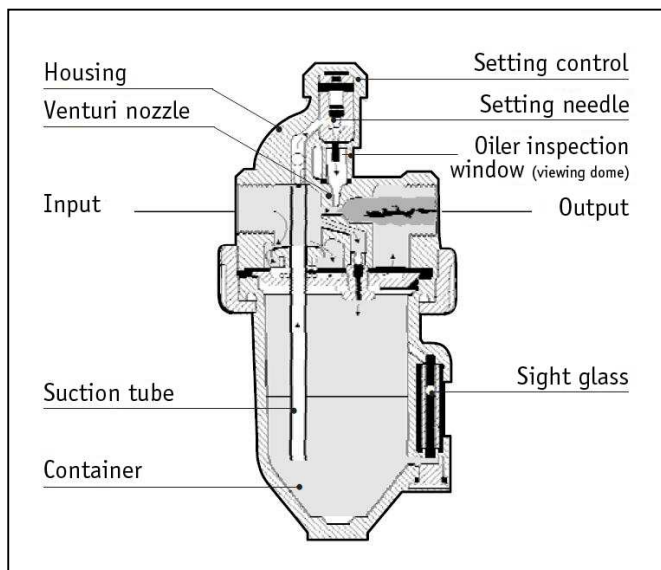

MOTOR INSTALLATION AND INSPECTION

CHECKING THE

- ▶ Brake linings
- ▶ Vanes
- ▶ Motor lubrication

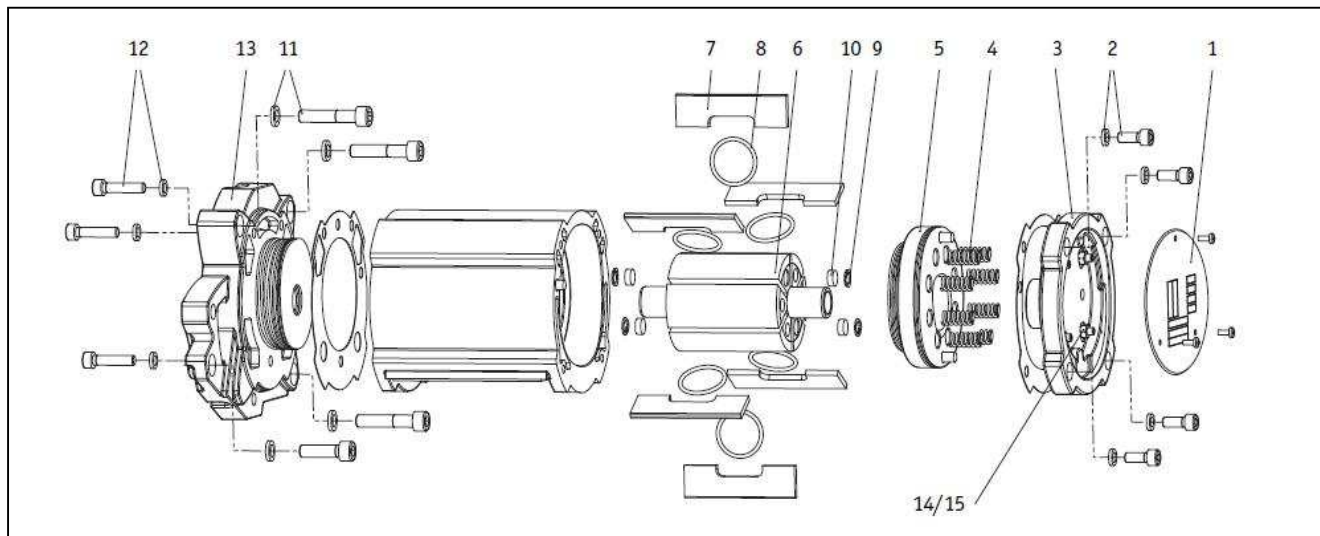

Motor installation / Replacing brake discs, brake piston and vanes

The motor and brake functions are achieved in part by means of shared components. The braking action is applied at the lateral surfaces of the rotor. The rotor is pressed via spring force from the cover-side of the motor against a second braking surface located on the opposite side by means of a piston onto which braking material is bonded.

REMOVAL

The hoist must first be unloaded and disconnected from the main air supply.

Note: The following operations can be performed from the nameplate side after the motor has been removed.

- ▶ Checking vane wear, replacing the vanes with starting aids if necessary.
- ▶ Checking brake wear, replacing the brake piston if necessary.
- ▶ Renewing the motor lubrication.

The replacement of the centre section halves with brake lining is described under a separate item.

- ▶ Remove the nameplate **1**.
- ▶ Remove the motor cover bolts **2** and detach the motor cover **3** (when the cover bolts are removed, tension in the brake springs **4** is fully released).
- ▶ Remove the brake springs.
- ▶ Remove the brake piston **5** from the internal cylinder

integrated in the motor housing.

- ▶ Remove the rotor **6** together with vanes **7** and starting aids **8**.

Checking vane wear:

(See illustration **Checking vane wear**, page 51). When the vanes are worn, the motor power and consequently the lifting performance are reduced. The vanes and starting aids must always be replaced together.

Checking braking surfaces of the brake piston and the centre section half with brake lining for wear and damage:

The circular wear pattern in the braking surfaces must not be deeper than 0.2 mm (see also illustration on page 51). The extremely low-wear braking material will not reach the wear limit of 0.2 mm within the design-dependent service life of the hoist, under intended use. Should the wear limit be reached prematurely, the actual pressure must be checked with the device switched on (the brake drags in the event of insufficient pressure).



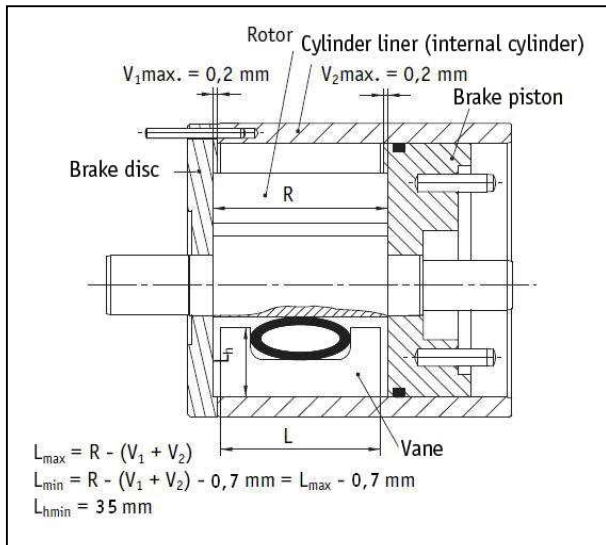

Checking vane wear

MOTOR LUBRICATION

Renewing motor lubrication:

Note: The grease packing in the rotor chambers is sufficient for approx. 250 hours of normal operation.

The rotor chambers only empty by approx. 75%. In this condition, refilling must be performed. The retaining rings **9** and Vyon washers **10** must be removed in order to refill the chambers.

Then fill the chambers with high-performance lubricant (JDN Part No. 11901) without forming cavities. Use new Vyon washers to close off the lubricant chambers and secure these using retaining rings.

Replacing flange with brake lining (to centre section):

If the centre section half with brake lining is to be replaced, the following removal operation is also required:

- ▶ Detach the hoist from the point of attachment and set down carefully.
- ▶ Detach the chain box if necessary.
- ▶ Remove the control valve.
- ▶ Unscrew centre section bolts **11**.
- ▶ Detach the motor with centre section half on the motor-side from the hoist.
- ▶ Remove the bolts **12** and pull out the centre section half with the brake lining **13**.

Motor installation with additional basic lubrication:

- ▶ Apply high-performance grease lightly to braking surface and rotor bearing (needle bush) in the centre section half and slide this into the motor housing. At the same time, insert the anti-twist device (pin).
- ▶ Bolt centre section half to motor housing.
- ▶ Coat the internal cylinder of the motor housing lightly with high-performance grease.
- ▶ Coat the entire rotor lightly with high-performance grease and insert into the front rotor bearing with the clutch side first.
- ▶ Coat the vanes lightly with high-performance grease and insert into the rotor slots with the starting aids.
- ▶ Coat the braking surface and the outer diameter including the brake piston seal lightly with high-performance grease and push the brake piston with the braking surface first into the internal cylinder. Note the position of the eccentric bore.
- ▶ Insert the brake springs into the bores of the brake piston.
- ▶ Loosen adjustment bolts **14** and lock nuts **15**. Screw back adjusting bolts sufficiently.
- ▶ Apply high-performance grease lightly to rotor bearing (needle bush) in the motor cover and install motor cover. Ensure correct seating of the brake springs and the locating pins to the motor housing and to the brake piston. Do not tighten the four adjusting bolts after bolting the motor cover in place, only screw them in loosely by hand to the stop in the cover. Screw back the lock nuts sufficiently beforehand.
- ▶ Then screw back the adjusting bolts 45° from the stop, hold and lock with the nuts. For lifting heights of 10m and more, a setting of up to 60° is required. For operation in areas with ambient temperatures exceeding 30°C, the adjustment must be carried out with the device warmed up accordingly.
- ▶ Screw on the nameplate.
- ▶ Push the motor with centre section half on the motor side onto the hoist – install load hook at same time – and tighten centre section bolts.
- ▶ Install the control valve.



ATTENTION!

Tightening torques, see E-list.



CAUTION!

Check the braking action of the hoist under load (run in the brake by performing several hoisting cycles, then assess) prior to initial operation. Check the motor power. In the event of low motor power, regulate the adjusting bolts again.



REMOVING AND INSTALLING BOTTOM BLOCK, CLAMP AND BUFFER

REMOVING AND INSTALLING BOTTOM BLOCK AND BUFFERS

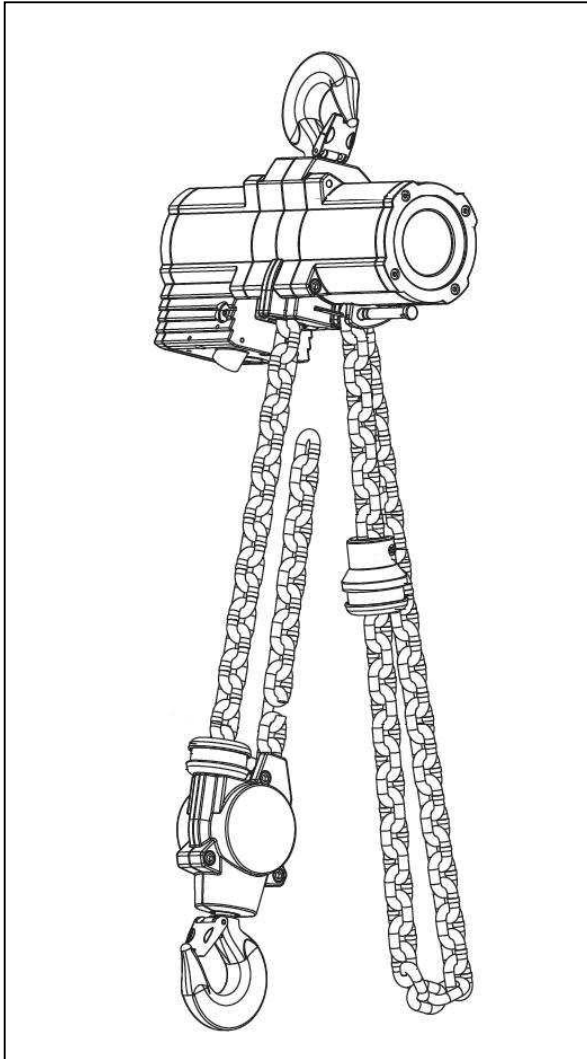

- DUAL CHAIN HOIST (25 TI)

Illustration of a dual chain device

Removal

- ▶ Move the bottom block as close as possible to the hoist body.
- ▶ Position the bottom block securely in order to prevent the chain from unravelling uncontrollably causing the bottom block to fall.
- ▶ Remove the bottom block end chain link from the chain mount on the hoist body; loosen screw connections and remove the end chain link pin for this purpose.

Note: For assembly, it is helpful to fasten a short assembly chain to the end of the chain by means of an open chain link before pulling the chain out of the bottom block. This assembly is pulled into the bottom block as the chain is pulled out and remains there until assembly is completed.

- ▶ Pull out the chain from the bottom block. The buffers, buffer discs and spacer are thereby pulled from the chain.

Assembly

- ▶ Push the buffer discs in the correct alignment (edge encloses buffer) and buffer onto the chain.
- ▶ Align the chain and fasten it to the assembly chain in the bottom block by means of the open chain link. Pull the chain through the bottom block and **detach the assembly chain and the open chain link from the chain**. If no assembly chains have been used, the end of the chain must be inserted into the bottom block and pulled through by turning the sprocket wheel using an auxiliary tool.
- ▶ Push the spacer back onto the chain, so that it is subsequently located in the chain between the bottom block and chain mount on the hoist.
- ▶ Align the bottom block chain and push the chain link pin through the chain link to be attached (position of the weld must align with that of the following links).
- ▶ Fasten the screw connection and secure using a new retaining washer to prevent it from becoming detached.



- TREBLE CHAIN HOIST (37 TI)

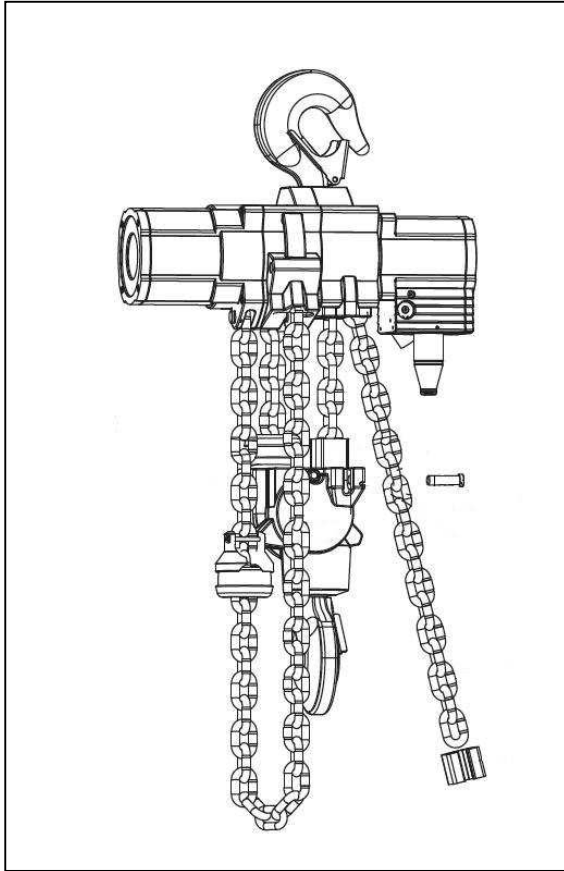

Illustration of a treble chain device

Assembly

- ▶ Push the buffer assembly in the correct alignment (buffer plus buffer discs, edge encloses buffer) onto the chains.
- ▶ Align the chain and fasten it to the assembly chain in the bottom block by means of the open chain link.
- ▶ Pull the chain through the bottom block and **detach the assembly chain and the open chain link from the chain.**
- ▶ Push the spacer onto the chain.
- ▶ Align the chain and pull through the centre section by means of the assembly chain.
- ▶ **Detach the assembly chain and the open chain link from the chain.**
- ▶ If no assembly chains have been used, the end of the chain must be inserted into both the bottom block and the centre section and pulled through by turning the deflection sprockets using an auxiliary tool.
- ▶ Push the second spacer onto the chain.
- ▶ Align the chain and fasten the chain link to the bottom block by means of the headed bolt (position of the weld must align with that of the following links).
- ▶ Fasten headed bolt sufficiently securely with new M24 self-locking nut. The headed bolt has slight axial play in the bore of the bottom block.

Removal

- ▶ Move the bottom block as close as possible to the hoist body. Position the bottom block securely in order to prevent the chain from unravelling uncontrollably causing the bottom block to fall.
- ▶ Remove the bottom block end chain link from the chain mount on the bottom block; unscrew the M24 self-locking nut from the headed bolt and remove the headed bolt.

Note: For assembly, it is helpful to work with two short assembly chains which are fastened by means of an open chain link to the hoist chain being pulled out during removal of the chain and are pulled successively over the deflection sprocket of the centre section and the bottom block. They remain there until assembly is completed.

- ▶ Pull the chain from the deflection sprocket of the centre section and from the bottom block. The buffer, buffer discs and spacers are thereby pulled from the chain.



- QUADRUPLE CHAIN HOIST (50 TI)

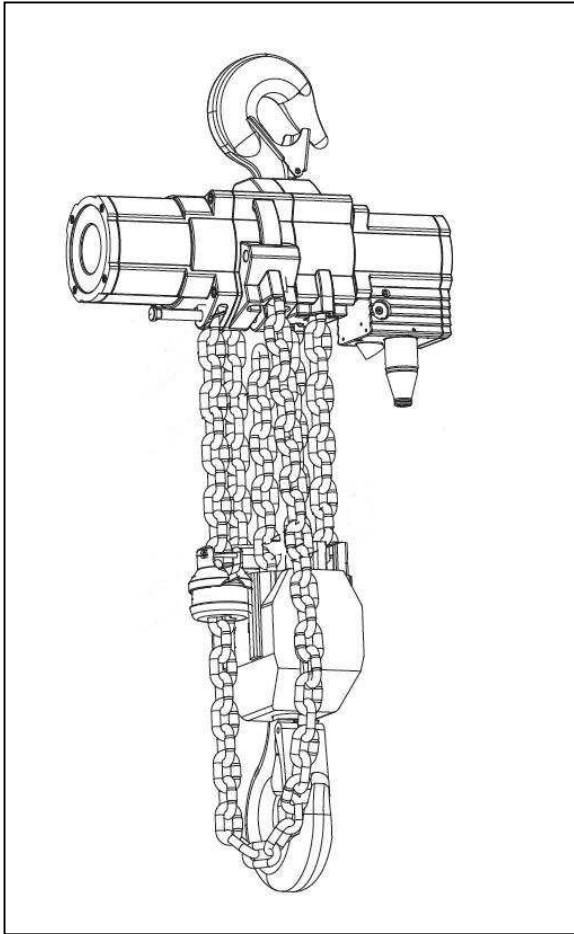

Illustration of a quadruple chain device

Removal

- ▶ Move the bottom block as close as possible to the hoist body. Position the bottom block securely in order to prevent the chain from unravelling uncontrollably causing the bottom block to fall.
- ▶ Remove the bottom block end chain link from the chain mount on the hoist body; remove the retaining plate and remove the end chain link pin for this purpose.

Note: For subsequent assembly, it is helpful to work with three short assembly chains which are fastened by means of an open chain link to the hoist chain being pulled out during removal of the chain and are pulled successively over the deflection sprocket of the centre section and the bottom block. They remain there until assembly is completed.

- ▶ Pull the chain from the deflection sprocket of the centre section and from the bottom block. The spacers, as well as the buffer and buffer discs are thereby pulled from the chain.

Assembly

- ▶ Push the buffer assembly in the correct alignment (buffer plus buffer discs, edge encloses buffer) onto the chains.
- ▶ Align the chain and fasten it to the assembly chain in the bottom block by means of the open chain link.
- ▶ Pull the chain through the bottom block and detach the assembly chain and the open chain link from the chain.
- ▶ Push the run-on element onto the chain.
- ▶ Align the chain and pull through the centre section by means of the assembly chain.
- ▶ **Detach the assembly chain and the open chain link from the chain.**
- ▶ Push the first spacer onto the chain.
- ▶ Align the chain and pull through the bottom block by means of the assembly chain.
- ▶ Detach the assembly chain and the open chain link from the chain.
- ▶ If no assembly chains have been used, the end of the chain must be inserted into both the bottom block and the centre section and pulled through by turning the deflection sprockets using an auxiliary tool.
- ▶ Align the chain and fasten the end chain link to the hoist body by means of the end chain link pin. (Position of the weld must align with that of the following links.)
- ▶ Attach the retaining plate for the end link pin. The retaining washers for securing the screws must always also be fitted.



REMOVING AND INSTALLING CLAMP AND BUFFER

Removal (see illustrations, page 52-54)

- ▶ In the case of operation with chain box, run the chain out of the chain box and detach it from the hoist.

Note: In the case of hoists with chain box, the end chain link of the idle chain is not attached to the hoist body.

- ▶ In the case of hoists without a chain box, remove the chain link of the idle chain from the chain mount at the hoist body. Loosen the screw connections and remove the shaped element with the chain from the hoist body.
- ▶ Loosen the screw connection of the clamp and remove it from the chain.
- ▶ Detach the buffer and buffer discs from the chain. In the case of operation with a chain box, the spacer must also be removed from the chain.

Assembly

In the case of operation with chain box:

- ▶ Push the buffer discs, with edge in the correct alignment (edge encloses buffer), together with the buffer and spacer onto the chain.
- ▶ Fasten the clamp to the 6th chain link and secure with screws. Tighten the screws to a torque of 354 Nm.
- ▶ Attach the chain box.

In the case of operation without chain box:

- ▶ Push the buffer discs, with edge in the correct alignment (edge encloses buffer), and the buffer onto the chain.
- ▶ Fasten clamp to 12th chain link and secure with screws. Tighten the screws to a torque of 354 Nm.
- ▶ Insert the shaped element into the recess on the hoist body.
- ▶ Align the chain link of the idle chain.
- ▶ Push the screw through the shaped element and chain.
- ▶ Tighten the screw to a torque of 608 Nm.



ATTENTION!

Do not twist the chain! The chain is subjected to impermissible stresses if the chain is twisted.



REMOVING AND INSTALLING CHAIN



ATTENTION!

The chain supplied together with this JDN hoist is matched to the chain sprocket according to strict tolerances. In order to ensure optimum function of the chain and in order to prevent hazards, only genuine JDN chains must be installed.

Note: When a chain is replaced, the buffers must also be replaced. For changing buffers at the chain ends, see **Removing and installing load sleeve, bottom block, clamp and buffer**, page 52ff.

Buffers and run-on elements not located on the chain ends are most easily replaced when the open chain link between the old and new chains passes the buffer to be replaced.



ATTENTION!

Do not twist the chain ends.

- ▶ In the case of operation with chain box: Switch the hoist in the “lower” rotational direction and run the old chain out of the chain box. Then remove the chain box.
- ▶ Move the bottom block as close as possible to the hoist body and position it securely.
- ▶ In the case of hoists without chain box, detach the idle chain from the chain mount on the hoist body, see also **Removing and installing load sleeve, bottom block, clamp and buffer**, page 52ff.
- ▶ Remove the clamp, buffer, buffer discs and where applicable spacers from the end of the idle chain.
- ▶ In the case of dual and quadruple chain hoists with chain box, detach the bottom block chain from the hoist body.
- ▶ In the case of treble chain hoists, detach the bottom block chain from the mount on the bottom block, see also **Removing and installing load sleeve, bottom block, clamp and buffer**, page 52ff.
- ▶ Attach the new chain to the end link of the load section of the old chain after aligning the welds and the first chain link by means of an open chain link. The welds on the upright chain links must face outwards when running over the chain sprockets. For this reason, the welds of the chain links which lie flat in the drive sprocket must face towards the gearbox in the case of treble and quadruple chain hoists.

If the first link of the new chain is not correctly positioned, it must be removed.

Note: It is possible that the first chain link of the other chain end is correctly positioned.

- ▶ Switch the hoist to the “lift” rotational direction. The new chain will now run into the hoist while the old chain is simultaneously run out on the idle chain side.

Run the chain until the join between the old and new chain has run sufficiently (approx. 1m) out of the centre section on the idle chain side.

- ▶ Detach the connection between the old and new chains.
- ▶ Install the clamp at the 12th or 6th chain link (in the case of operation with chain box), buffer, buffer discs and, where applicable, spacers on the idle chain section of the new chain.

In the case of operation without a chain box, align the idle chain and attach at the mounting point on the hoist body, see also **Removing and installing load sleeve, bottom block, clamp and buffer**, page 52ff.

- ▶ Attach the chain box if necessary.
- ▶ Switch the hoist in the “lift” rotational direction until the as yet free end of the aligned load chain is the correct length for attaching the chain link – for dual and quadruple chain hoists, at the mounting point on the hoist body – for triple chain hoists at the fastening point of the bottom block, see also **Removing and installing load sleeve, bottom block, clamp and buffer**, page 52ff.

Note: If the chain link of the load chain is positioned incorrectly, it must be removed, the following chain link will be positioned correctly.



REPLACING CHAIN AND CHAIN SPROCKET

When removing the old chain and replacing the drive chain sprocket, assembly chains are brought into position on all the deflection sprockets by means of open chain links see also **Removing and installing load sleeve, bottom block, clamp and buffer**, page 52ff and **Removing and installing chain**, page 56.

Note: If the deflection sprockets are also replaced, drawing in the assembly chains via the deflection sprockets is not necessary.

Following replacement of the chain sprocket (see spare parts list) an assembly chain is run carefully – with low air pressure – over the drive sprocket.

After replacing the deflection sprockets, assembly chains must be carefully guided over the deflection sprockets manually.

Fasten the new chain to the assembly chain on the drive sprocket by means of one or two open links on the idle chain side. The first chain link must run upright over the drive sprocket with the weld facing outwards. The welds of the chain links which lie flat in the drive sprocket must face towards the gearbox in the case of treble and quadruple chain hoists.

(See illustration **Drawing in the chain**).

Switch the hoist to the “lower” rotational direction and detach the assembly chain from the chain after it comes out of the centre section.

Depending on the number of chains of the hoist and after alignment, the new chain is pulled over the deflection sprocket of the bottom block and if necessary over the deflection sprocket of the centre section by means of further assembly chains.

Note: If the chain link on the idle chain side is positioned incorrectly, it must be removed, the following chain link will be positioned correctly.

For fastening of the chains and installation of the clamp, buffer, buffer discs and, where applicable, spacers, see **Removing and installing load sleeve, bottom block, clamp and buffer** page 52ff and **Removing and installing chain**, page 56.

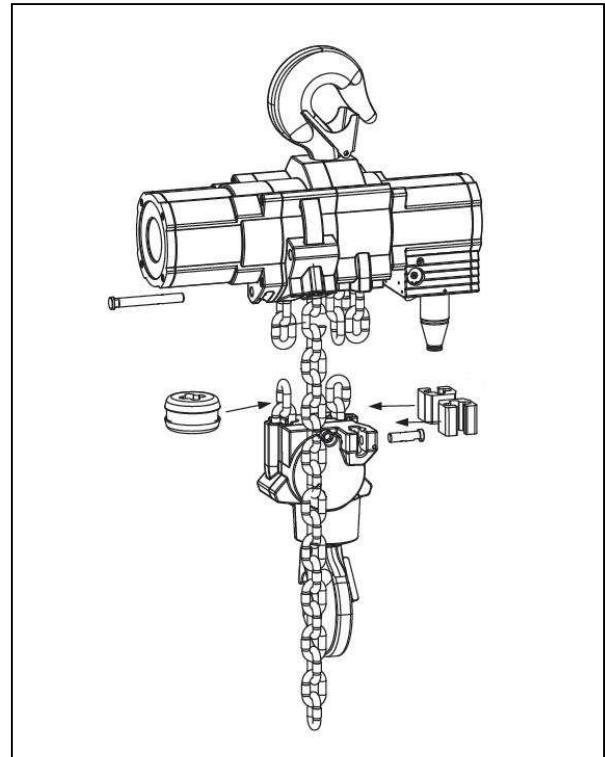

Illustration of “Drawing in the chain”



CHECKING THE CHAIN, CHAIN SPROCKET AND CHAIN GUIDES

See also **Check dimensions**, page 58.

If the chain of the JDN Air Hoist displays one of the following features, it must be replaced with a new one:

- ▶ Corrosion pitting
- ▶ Bent or damaged chain links
- ▶ Chain drawn tight
- ▶ Wear over 11 pitches (A_{max})
- ▶ Single pitch wear (B_{max})
- ▶ Elongation of a single link (D_{max})

Check the entire length of the chain.

Please observe the information contained in DIN 685, Part 5 when checking chains, see ISO 7592.

CHECK DIMENSIONS

HOIST CHAIN

Note: When checking the replacement limit, future wear up until the next inspection date must be taken into account. If the chain dimension values are outside the limit values specified in the table when checked, the chain has reached its replacement limit and must be replaced by a new one. The worn chain sprockets must also be replaced together with the chain, as otherwise the new chain will be subjected to increased wear. Each chain replacement must be documented in the inspection log.

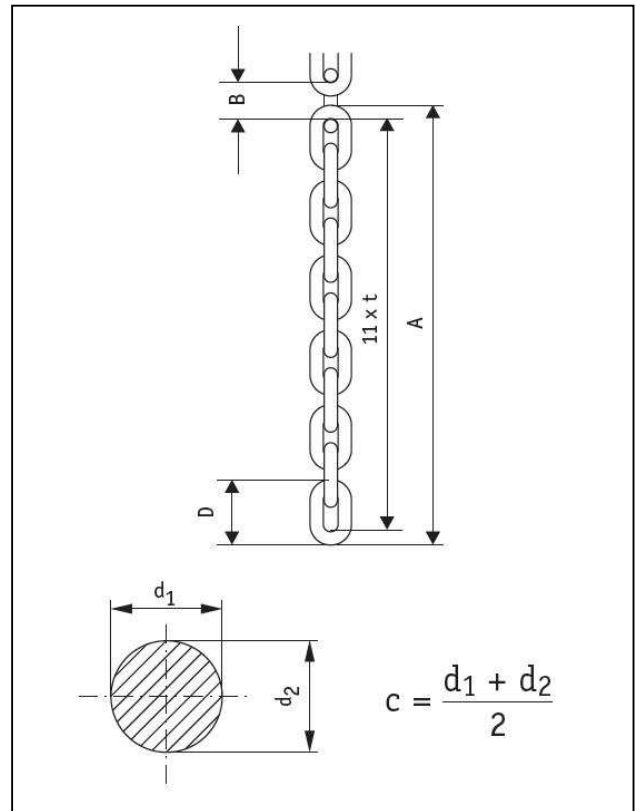

Check dimensions of hoist chain

Chain d x t	23.5 x 66
Dimension A_{max} .	787.9
11 x t _{inside}	743
Dimension B_{max} .	69.5
Dimension C_{min} .	21.2
Dimension D_{max} .	116.4

Dimensions in mm



LOAD HOOK

If the hook opening "a" or the height "h" of the load hook are outside the wear limits, the hook must be replaced.

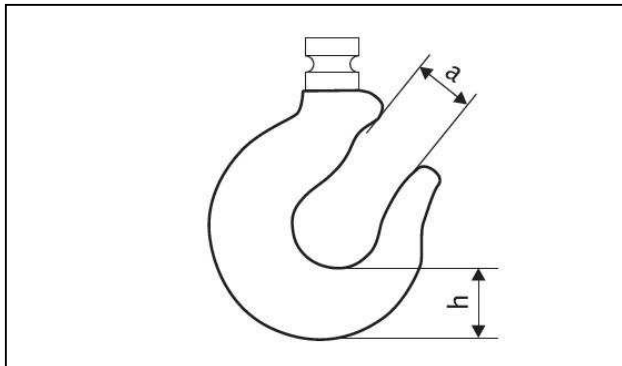

Check dimensions of load hook

Device type	Permissible max. dimension of hook opening "a" ¹⁾	Permissible min. value of height "h"
PROFI 25TI	83.4	80.8
PROFI 37TI / 50TI	110.2	116.9

Dimensions in mm

1) If a safety catch is fitted, the thickness of the safety catch must be subtracted from the maximum hook opening dimension "a".

WEAR DIMENSIONS FOR CHAIN SPROCKETS

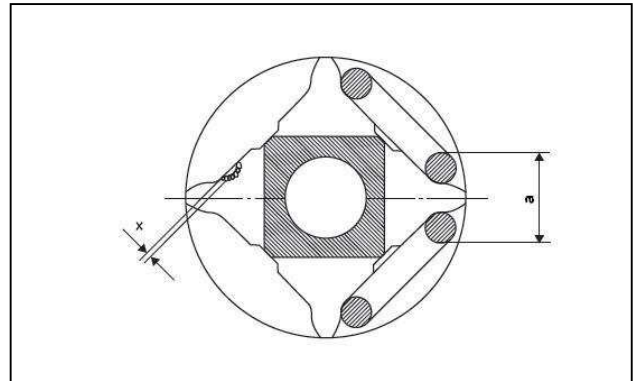

Check dimensions for chain sprockets

Chain size d x t [mm] x [mm]	z [-]	a [mm]	x [mm]
23.5 x 66	4	60.0	0.45
	5	59.6	0.45

a, x = Limit dimensions after max. permitted wear

z = Number of teeth of the chain sprocket

d x t = Nominal diameter times pitch of chain link

WEAR DIMENSIONS FOR CHAIN GUIDES AND HOOK MOUNTS

Check the chain guides for wear and if the following wear dimensions are reached with regard to chain guide diameters or hook mounts in the centre section of the device, replace the housing:

Chain diameter	23.5
Wear dimension	2.3

The wear dimension must be measured at the points on the guide surfaces which have been worn down by the chain.



CHECKING AXIAL PLAY

Maintenance and lubrication

Please ensure that the load hooks and/or the load eye mounts are regularly checked at least once a year. **Especially important:** in areas where wear-promoting conditions such as high ambient temperatures or corrosive substances in the atmosphere are present, or where lubricants may be washed out, **the frequency of maintenance and inspection intervals must always be increased.**

HAZARDS IN THE CASE OF INSUFFICIENT MAINTENANCE/LUBRICATION



DANGER!

In the event of insufficient maintenance/lubrication the extent of wear may be so high that there is a danger of loads falling.

PREVENTING RISKS

Dangers are avoided by regular maintenance/lubrication in suitable intervals.

When the axial play of the installed hook and bottom block increases rapidly, it must be assumed that the hardened surface of the hook mount is worn. The worn parts of the hook mount must then be replaced immediately.

The actual dimensions of the hook mount must be measured and recorded before initial operation. Following repair or overhaul of the hook mount, the actual dimensions must be determined.

Rapid wear can be detected quickly due to the rapid increase in the dimension "x". The point of departure is the actual measured dimension in new condition.

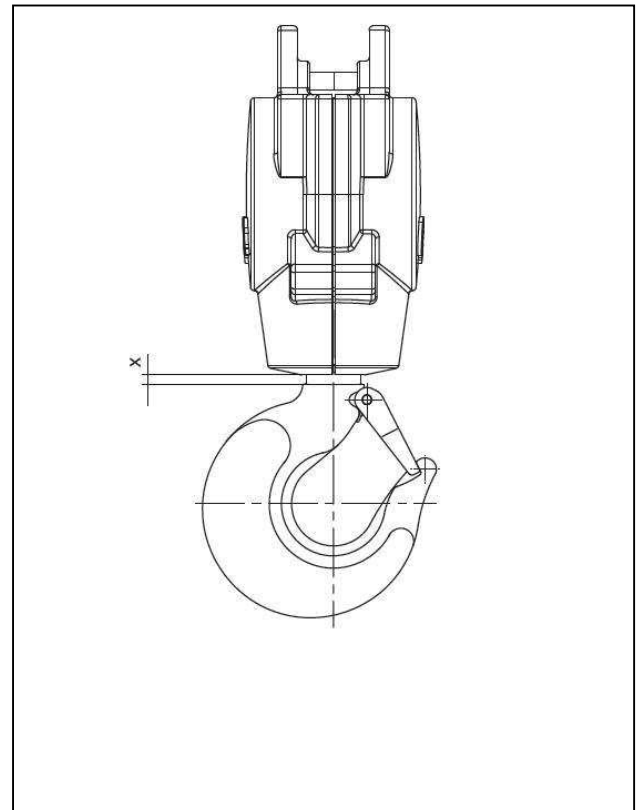

Bottom block with load hook

Axial hook play	Date	25TI	37TI & 50 TI
Actual dimension			
Dimension "x"			

* Actual dimension of new device or after overhaul



CHECKING AND ADJUSTING OVERLOAD PROTECTION

All JDN Air Hoists are equipped with overload protection as standard. This automatically deactivates the lifting movement of the load hook if the hoist is loaded to the pre-defined load parameter or higher. The switch-off point is 110% to 125% of the permitted maximum load. After load hook is switched off, the only movement available is lowering.

The overload protection can also be activated if the hoist is moved at full unloaded speed and with a slack chain against a load to be lifted, even when it is below the load size set.

We therefore recommend slowly tensioning the slack chain before lifting the load.

OVERLOAD TESTING ON PROFI 25 TI TO PROFI 50 TI

The overload protection can be overridden for the purpose of an overload test by simply unscrewing the screw plug.



DANGER!

After the test, make sure to screw the screw plug back in and ensure that it fits tightly.

- ▶ Unscrew the screw plug. The high-pressure air valve is not now activated on the "Lift" side. For this reason the deactivation function has no effect.
- ▶ After the test, screw the screw plug back in and ensure that it fits tightly.

ADJUSTING OVERLOAD PROTECTION

The adjustment method described here is based on the attachment of test loads.

The adjustment is usually made at room temperature (approx. 20°C).

In the event of very high or very low operating temperatures, the adjustment is to be corrected in relation to the temperature.



DANGER!

If the overload protection is set too high, impermissibly high stresses may arise if a load exceeding the permissible load carrying capacity is attached.

There is a danger that the chain and device could break.

- ▶ Attach overload of 125% of the load-carrying capacity.
- ▶ If the overload is lifted, the adjusting bolt must be adjusted clockwise until it is no longer possible to lift the overload.
- ▶ If the overload is not lifted, the adjusting bolt must be adjusted anticlockwise until it is possible to lift the overload. The adjusting bolt must then be turned back until it is just no longer possible for it to lift the overload.
- ▶ After the adjustment process, it must be possible to lift 110% of the nominal load. A dynamic overload test at 110% of the nominal load is thus possible.

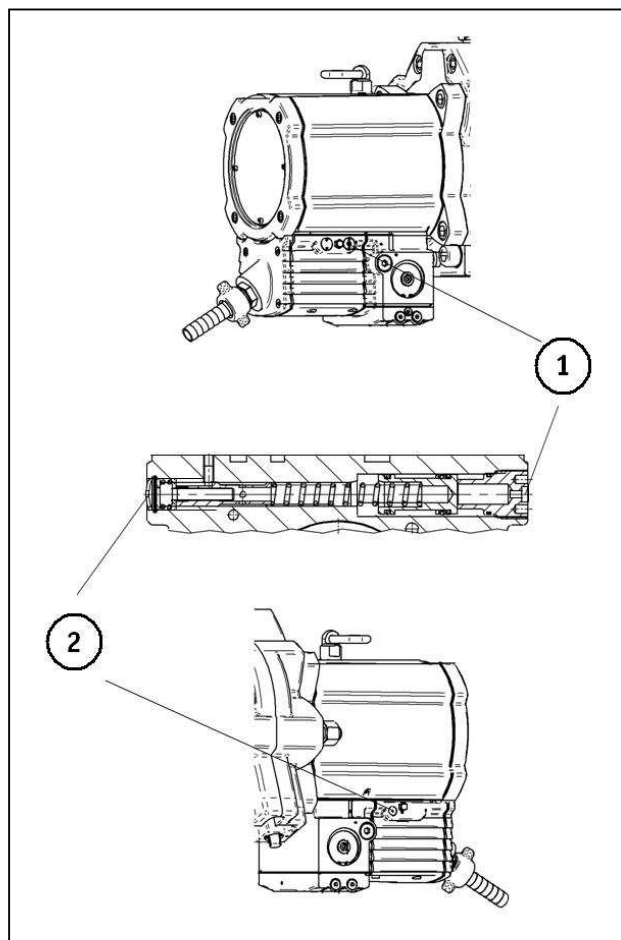

Control valve with overload protection

- (1) Screw plug for overload test
- (2) Locking disc with cylinder screw for adjusting the overload protection



FAULT TABLE

Fault	Possible cause	Remedy
Lifting not possible	Air pressure too low	Increase air pressure to the required value
	EMERGENCY STOP button is pressed	Release the emergency-off switch if the danger has been rectified
	Hand control is faulty	Have hand control repaired
Only very slow lifting possible	Brake does not release fully	Set air pressure to the relevant value, check seal of brake piston and change seal if necessary Check the adjustment of the brake piston (see E-list)
	Brake lining worn or uneven	Replace brake lining
	Motor cover bolts loose	Tighten the bolts
	Air supply hoses leaking or loose	Check connections of air supply hose and control hoses and connect properly
	Cross section of air line too small	Use air line with sufficiently large cross section (check air pressure)
	Dirt in the service unit*, filter blocked	Clean service unit, ensure better air quality
	Silencer is clogged	Replace or clean silencer elements, improve air quality if necessary
	Motor vanes worn	Replace motor vanes
	Motor has run dry.	Lubricate motor, check oiler*
	Control valve on motor	Have control valve repaired
Excessive running on during braking	Brake disc and/ or brake piston worn	Replace brake disc and/ or brake piston
Loud chain noise on the chain sprocket	Chain dry Chain worn	Lubricating the chain Replace chain with a new JDN Chain
	Chain sprocket worn	Replace chain sprocket, check chain guide, replace if necessary
	Wrong chain drawn in	Identify chain and replace with JDN Chain if necessary
Lifting or lowering speed declines with high lifting heights or the motor comes to a standstill	Brake piston setting too tight	Correct adjustment of brake piston. At high ambient temperatures, perform adjustment with the device warmed up accordingly.

*if installed



ACCESSORIES

FILTER SILENCER

With the use of a filter silencer, oil aerosols can be avoided and noise insulation improved:

- ▶ 99.9% of oil aerosols during oil lubrication of the motor are absorbed by the filter element.
- ▶ The noise insulation reduces noise levels by 3 to 4 dB (A) compared with the standard silencer.

The ambient temperature must not be lower than -10°C .

MAINTENANCE OF FILTER SILENCER

The filtered oil runs into the transparent collecting container **3**. This container must be emptied before the fluid level reaches the filter element.

- ▶ Turn the drain valve **4** by 90° and allow the fluid to drain out.
- ▶ Close the drain valve again by turning back.

The filter must be replaced after approx. 2500 hours of operation.

- ▶ Turn the collecting container **3** slightly and detach.
- ▶ Unscrew the filter element **2**.
- ▶ Insert a new filter element **2**, with sealing ring **1** and push on collecting container **3** until it engages.

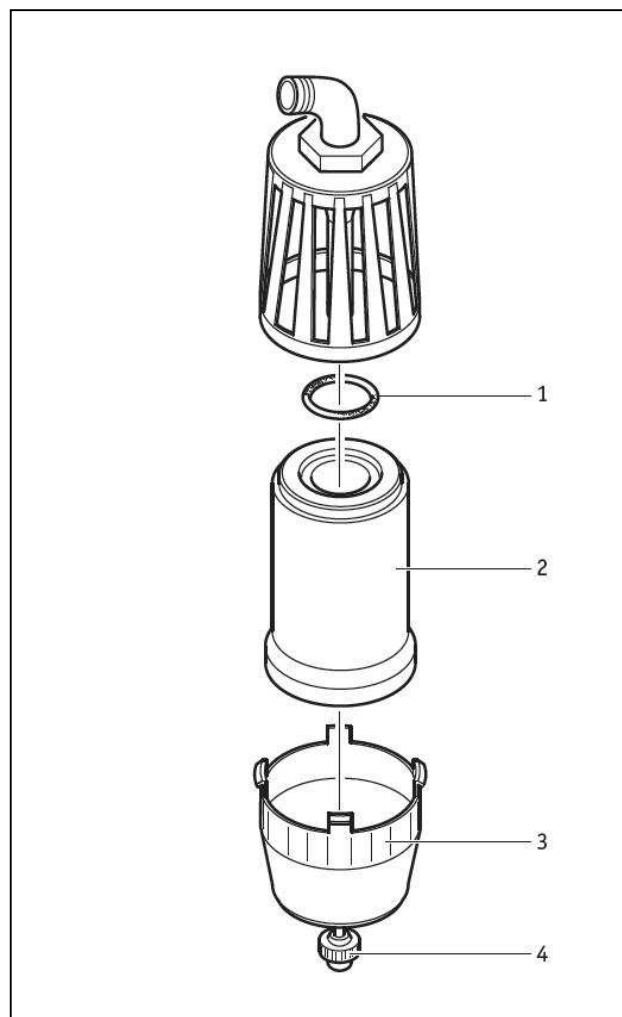

Filter silencer

BOOSTER UNIT

In the case of a control hose length exceeding 12m, the reaction times of the pushbutton controls increase significantly.

Consequently, a booster unit is generally installed on the motor for controls E and F, enabling normal reaction times.

The operating temperature range is from 0°C to 80°C .



CHAIN BOX

In various application situations, a chain box enhances operational safety, e.g. if a chain that is hanging down could become caught up with the load.

JDN chain boxes are available in various sizes, corresponding to the chain lengths.



ATTENTION!

Do not exceed the permissible filling capacity.
Danger of chain falling.



ATTENTION!

Loads must not be moved against the chain box during lifting. **Please contact us, if required.**

A clamp must be attached in the 6th chain link of the unloaded chain end so that a length of chain remains in the chain box when the bottom load hook position is reached. Thus, the chain cannot run next to the chain box during subsequent lifting (see **Removing and installing chain** page 56).

Depending on the ratio of the size of the hoist (without running gear) and the chain box, the chain box may have to be stabilised by the customer due to an acceptable vertical hoist position.

This is facilitated by a suspension point on the rear of the box. We will be happy to answer any questions on this matter.

Modifications may only be made to the chain box on agreement with J.D. Neuhaus GmbH & Co. KG.



ATTENTION!

Never allow the chain to pile up in the chain box.

The chain must only enter the container via the chain drive. If it falls out of the container, e.g. during transportation, it must be run out completely on the load hook side and then run back into the container via the chain drive, in the air hoist operating position.

- ▶ After installing the chain box, lower the load hook to the bottom position once.
- ▶ Then activate the lifting movement and run the complete chain into the chain box.



DANGER!

When operated with a chain box, lubrication of the chain is particularly important in order to prevent it from piling up and falling out of the box. Do not install longer chains when changing chains.

Furthermore, hazards arise due to rusty chains when operating with chain boxes, as the chain can form a heap and fall over the edge of the container rim. In addition, rusty chains are subject to extreme wear.

If the hoist has been transported with the chain in the chain box, the chain box must be emptied manually before initial operation (if necessary, remove the chain box from the hoist). The entire chain must then be allowed to run to the load side and, subsequently, be driven back into the chain box. The hoist must be kept in a hanging position during this procedure. This process will ensure that the chain does not lock when loads are being lowered.



APPENDIX

TECHNICAL DATA

Type		25 TI	37 TI	50 TI
Load-bearing capacity	t	25	37.5	50
Number of chain sections		2	3	4
Air pressure	bar	6		
Lifting speed at nominal load	m/min	1.25	0.75	0.55
Lifting speed without load	m/min	2.4	1.7	1.3
Lowering speed at nominal load	m/min	2.8	2.0	1.6
Air consumption at nominal load, lifting	m ³ /min	6.5		
Air consumption at nominal load, lowering	m ³ /min	2.9		
Air connection		G 1 ½		
Hose size (∅ inside/ ∅ outside)	mm	35 / 51		
Weight for standard lift / rope control	kg	550	850	940
Chain dimensions	mm	23.5 x 66		
Weight for 1m chain	kg	12.2		
Standard lift	m	3		
Control length for standard lift	m	2		
Noise pressure level with nominal load with standard silencer - lifting ¹⁾	dB (A)	78		
Noise pressure level with nominal load with standard silencer - lowering ¹⁾	dB (A)	82		

¹⁾ measured from 1 m distance according to DIN 45635 Part 20

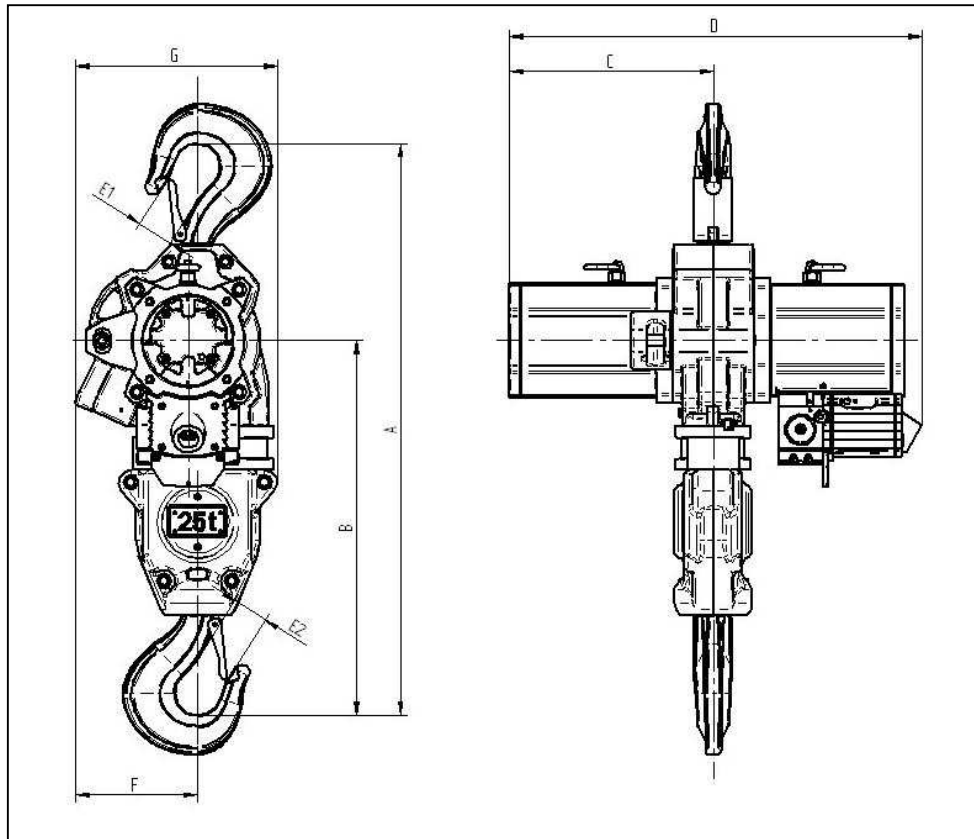

DIMENSIONS

Dimensions		25 T1	37 T1	50 T1
A minimum headroom ²	mm	1260	1470	1485
B	mm	827	935	950
C	mm	450	540	540
D	mm	900	1080	1080
E ₁	mm	75	100	100
E ₂	mm	75	100	100
F to centre of hook, without chain box	mm	270	285	250
G	mm	445	450	430

²⁾ Chain boxes increase the required headroom



J.D. NEUHAUS
powered by air!

CIRCUIT DIAGRAM

Rope control

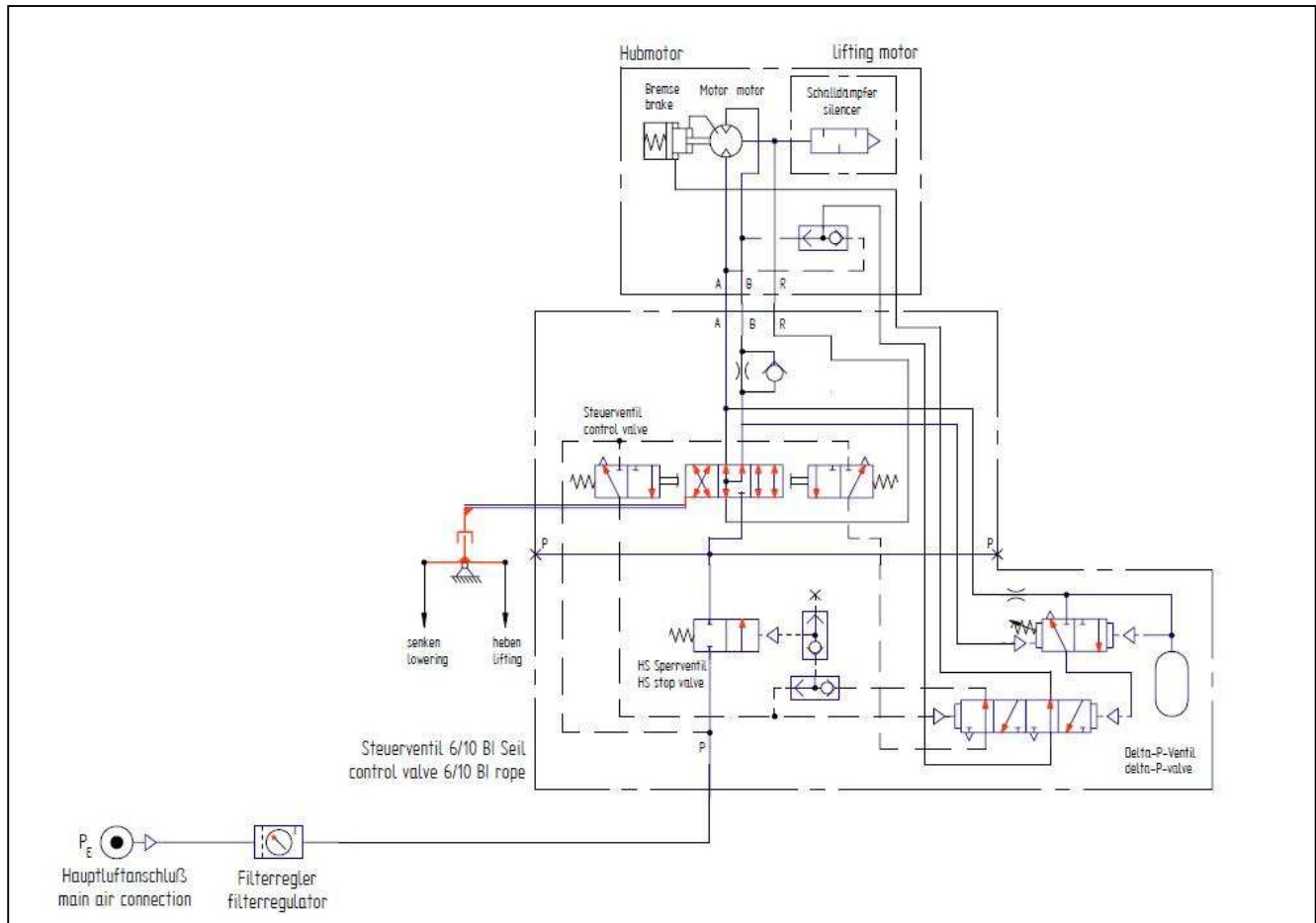

J.D. NEUHAUS
powered by air!

Dual control

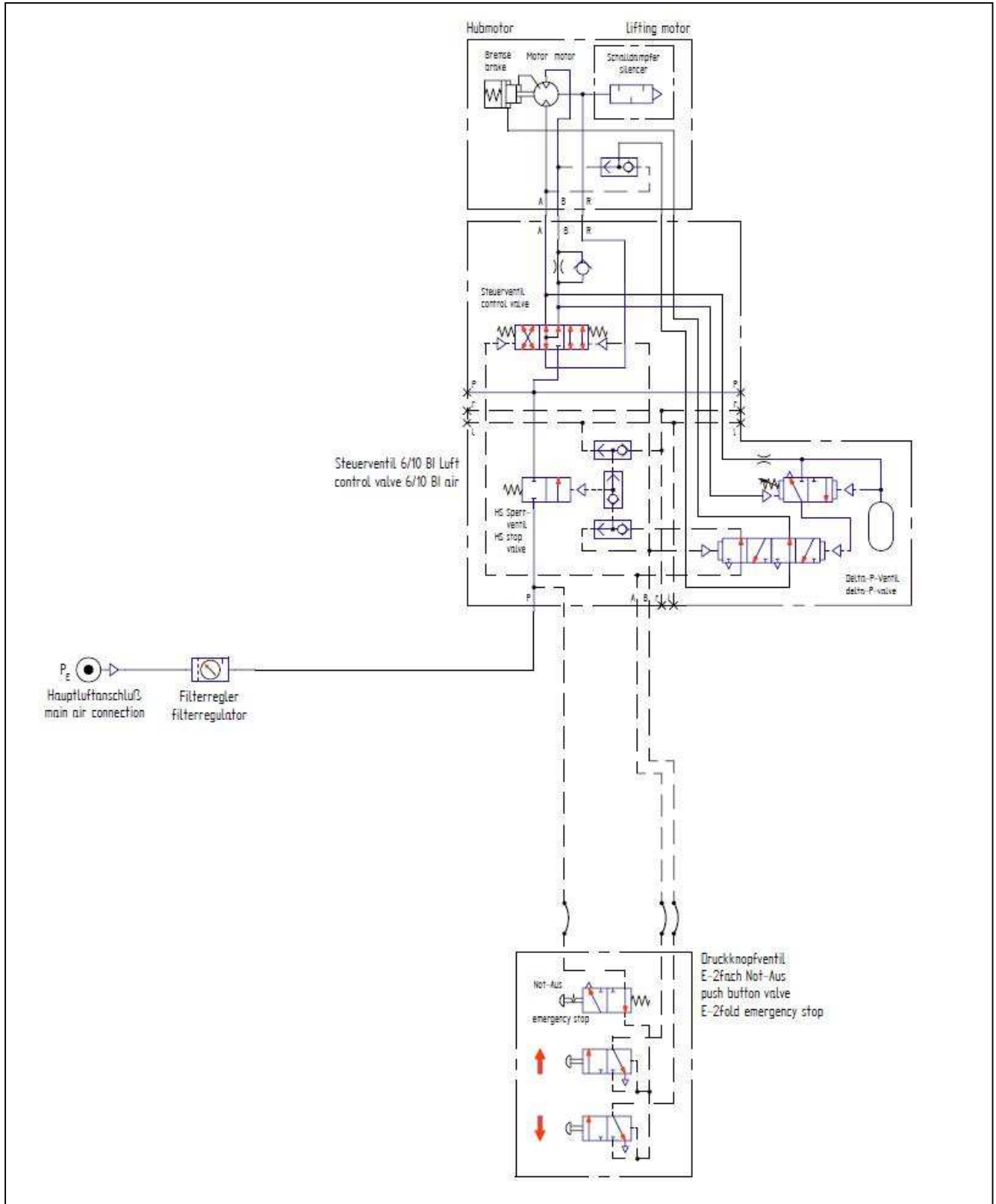

Dual control with pin valve, "Lower" side (OPTIONAL)

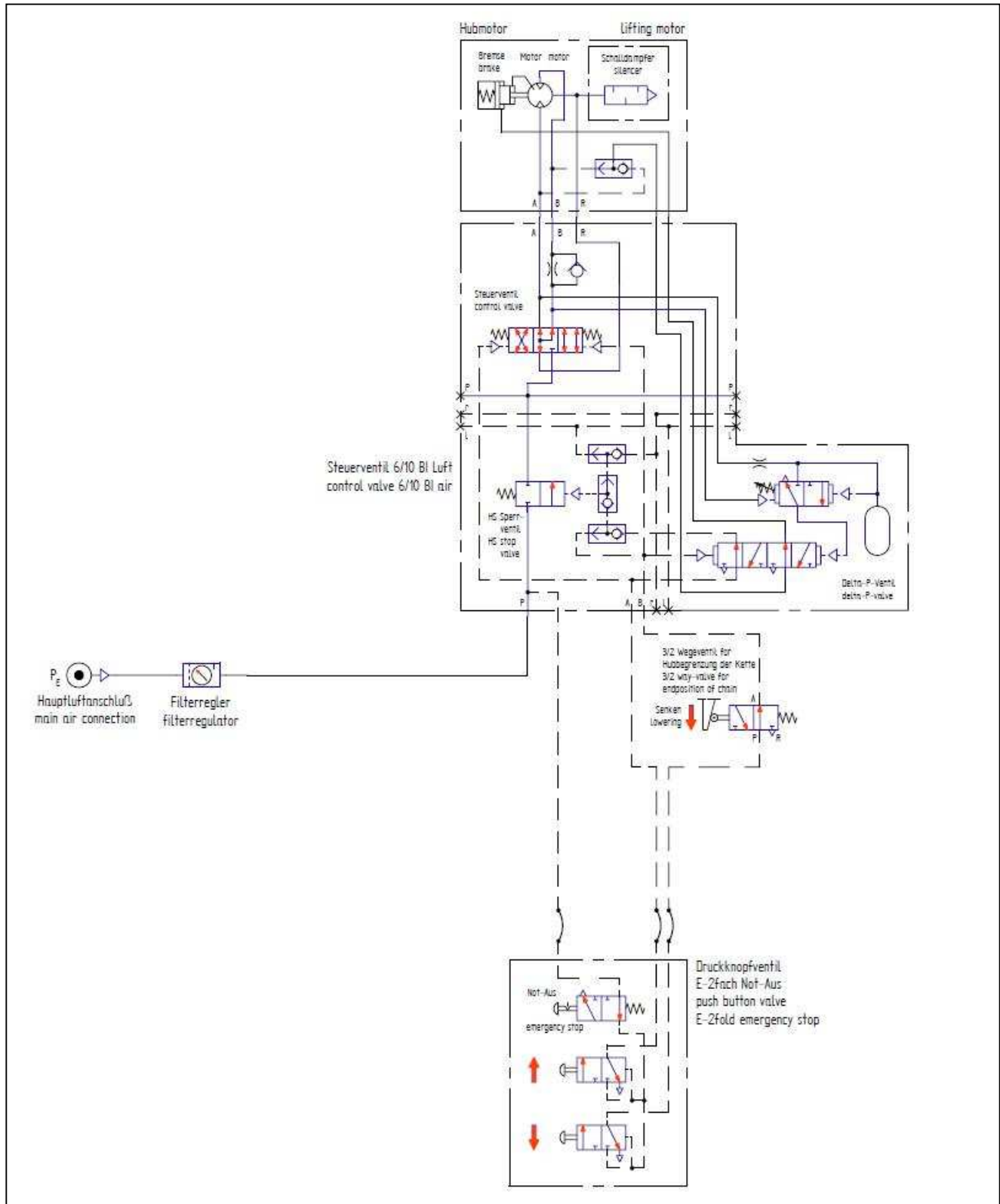

J.D. NEUHAUS
powered by air!

Quadruple control

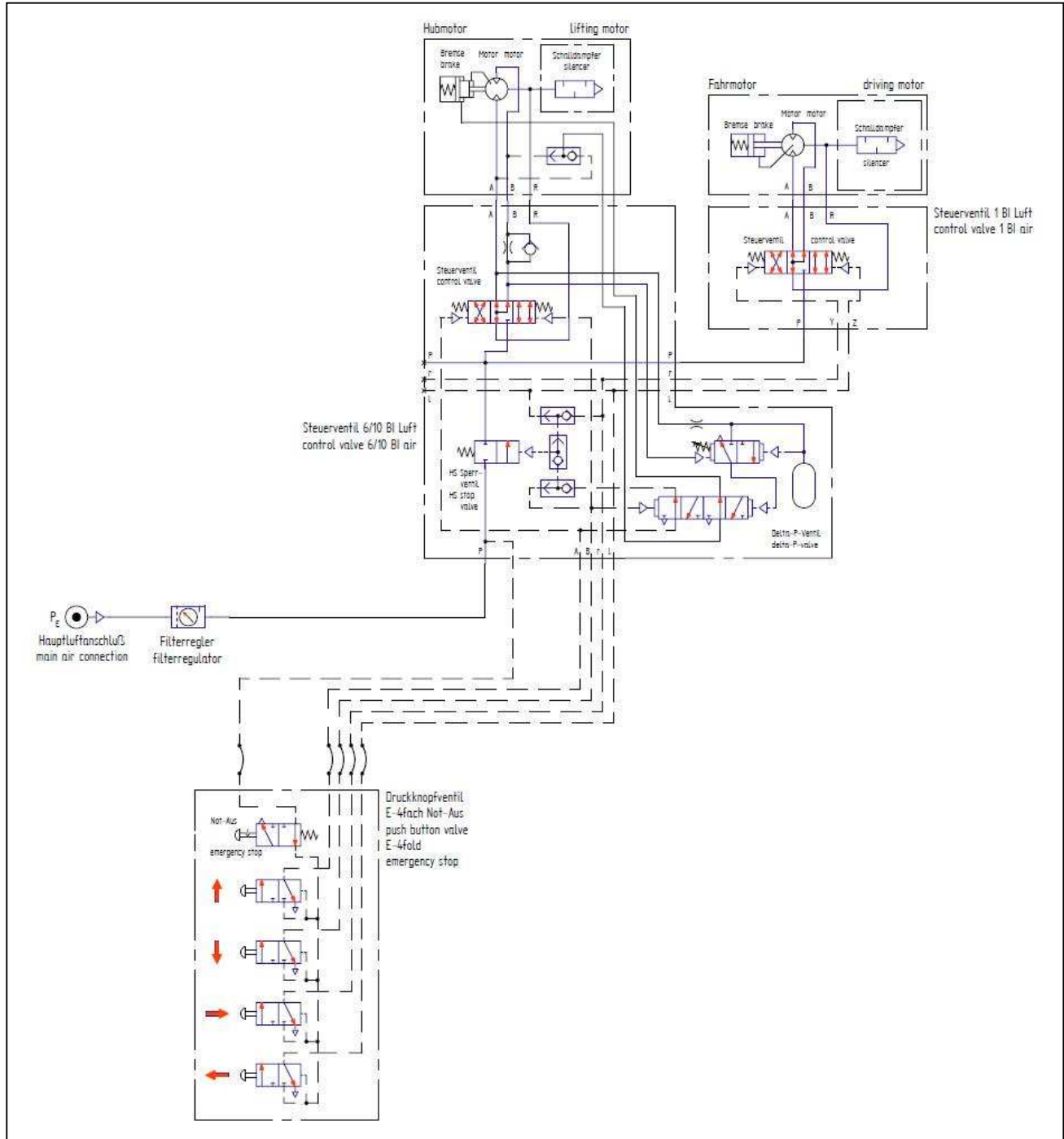

Quadruple control with pin valve, "Lower" side (OPTIONAL)

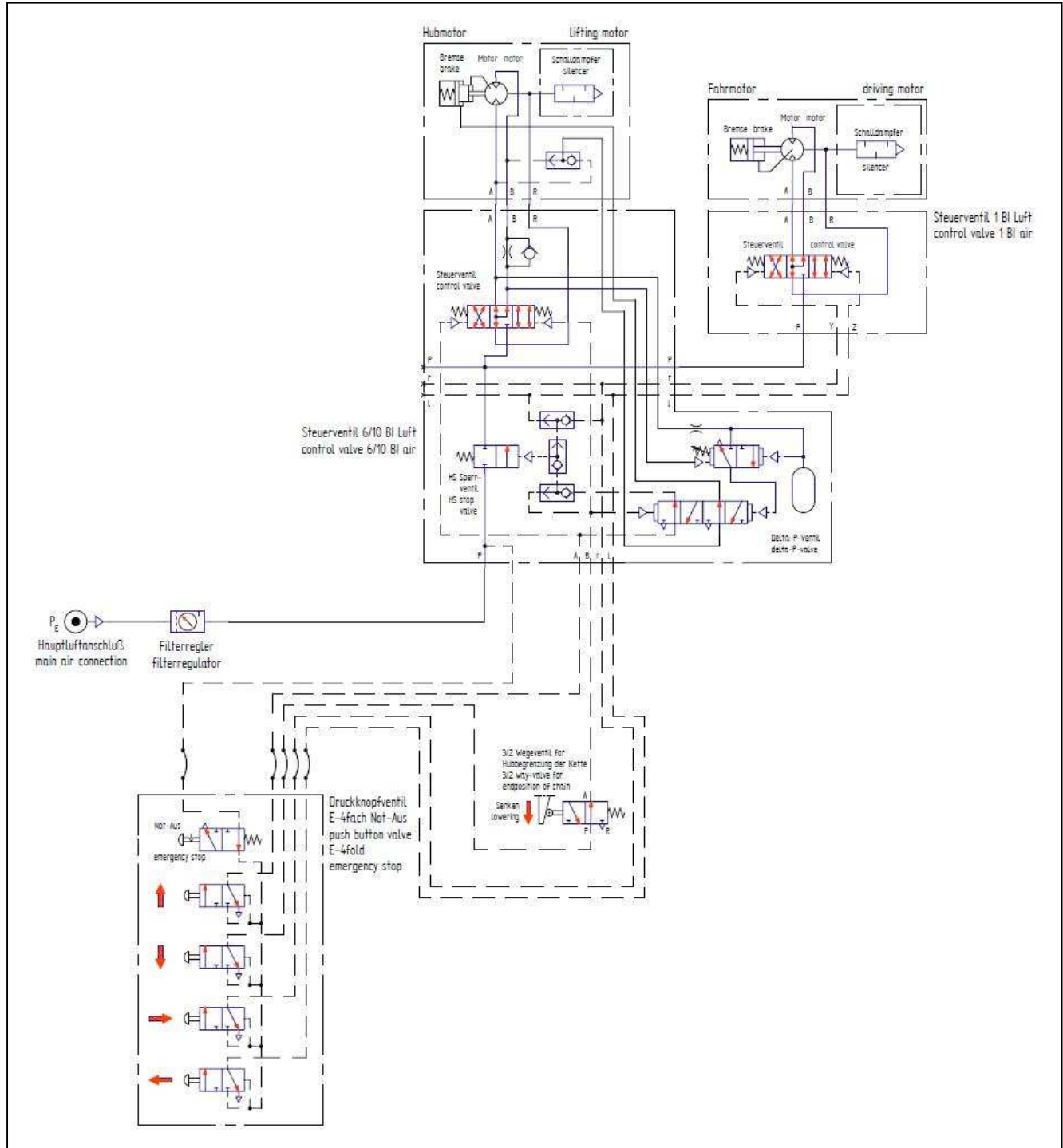

PROFI TT® is a registered trade mark of our company.
BA 822 EN - Issue: March 2012 – Subject to changes –

J.D. NEUHAUS GmbH & Co. KG / D-58449 Witten-Heven
PHONE +49(0)2302 208-0 / FAX +49(0)2302 208-286
website: www.jdn.de / e-mail: info@jdn.de



J. D. NEUHAUS
powered by air!