

OPERATOR'S MANUAL

R-Series Roust-a-Bout

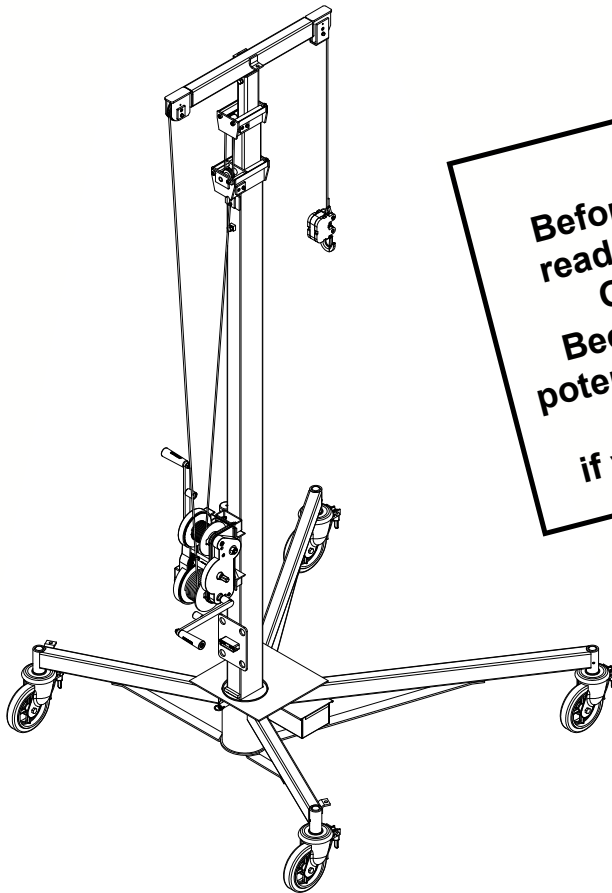

WARNING!
Before operating this lift,
read and understand this
Operator's Manual.
Become familiar with the
potential hazards of this unit.
Call SUMNER
if you have any questions.

SUMNER™

 A Southwire Company

USA

7514 Alabonson Rd.
Houston, TX 77088
p: 281-999-6900
f: 281-999-6966

CANADA

75 Saltsman Drive, Unit 5
Cambridge, Ontario N3H 4R7
p: 519-653-5300
f: 519-653-5305

NETHERLANDS

Midden Engweg
21NL-3882TS Putten
Netherlands
europeansales.com
p: + 31 (0) 85 489 0284

UK

Unit 3 Kempton Road Keytec 7
Business Park Pershore,
Worcestershire WR 10 2TA, UK
p: + 44 (0) 1386 556278
f: + 44 (0) 1386 556776

INDEX

Operator Safety Instructions	4
Specifications	5
Assembly Instructions	6-11
Moving Roust-a-Bout to work area (no load)	6
Moving Roust-a-Bout (with load)	6
Elevating Mast	6-7
Attaching Lift Cable to Object	7
Elevating Load	7-8
Lowering Load	8
Lowering Mast	8
Removing Mast	8-9
Caster Brakes	9
Handle Storage	9
Shear Pin	9
Options: Tee Head Extension	9-10
Model R-250 Guy Line Instructions	11
Maintenance Instructions	12
Winch Maintenance	12
Replacing the Cables	12
General Maintenance	12
Troubleshooting	13
Maintenance Record	14

OWNER'S RESPONSIBILITIES

Throughout this publication, the words **WARNING**, **CAUTION** and **IMPORTANT** will be used to alert the user to special instructions concerning a particular operation that may be hazardous if performed incorrectly or carelessly.

OBSERVE THEM CAREFULLY !!

WARNING



Hazards or unsafe practices which could result in severe personal injury or death.

CAUTION



Hazards or unsafe practices which could result in minor personal injury, product or property damage.

IMPORTANT



Indicates information or instructions that are necessary for proper operation and/or maintenance.

OPERATOR SAFETY INSTRUCTIONS



IMPORTANT

Read and understand Operators Manual before using Roust-A-Bout



Inspect cable before use. Do not operate if cable is frayed, worn or damaged.



Never allow anyone under an elevated load.



Use only on solid level surface. Keep work area clear of clutter and debris.



Never leave Roust-A-Bout unattended with an elevated load.

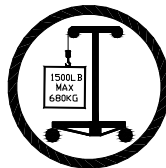

Test load balance before lifting. Do not exceed rated load capacity. Never use two Roust-A-Bouts to lift a load which exceeds the capacity of a single lift.



Do not climb on Roust-A-Bout or put side load on mast.

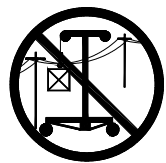

Stay clear of overhead wires and obstructions.



Do not operate during storms.



Do not operate in gusty winds.

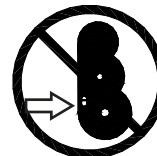

Never lower load using free fall lever. Keep lever engaged at all times under loaded conditions.

OPERATOR SAFETY INSTRUCTIONS (CONTINUED)



Do not use Roust-A-Bout over 20 ft (6.1 m) without using Guy Lines.



Never lift a load over the short legs unless a counter weight equal to the load is applied to the long legs.

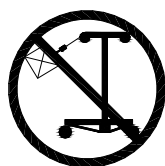

Do not pull or drag load.

Do not move the Roust-A-Bout by pulling on load line.

Do not raise or lower loads over 500 lb (225 kg) by raising masts.

Do not use accessories with the Roust-A-Bout that are not supplied by the manufacturer.



Wear proper clothing. Hard hat, safety shoes, and gloves should be worn as a precaution while operating this lift.

Avoid horseplay around equipment, and keep bystanders at a safe distance. Do not allow children to operate this unit and always keep them out of work areas.

Always match Base and Tee Head to correct model Roust-A-Bout.

SPECIFICATIONS

Model	Maximum Lifting Capacity*	Maximum Height
R-100	1500 lbs (680 kg)	15' 2-1/2" (4.6 m)
R-150	1500 lbs (680 kg)	15' 2-1/2" (4.6 m)
R-180	1500 lbs (680 kg)	17' 11-5/8" (5.5 m)
R-250	1500 lbs (680 kg)	25' 3/8" (7.6 m)

*1,000 lb. (455 kg) Limit (all models) with optional Tee Head Extension Bar

For **OVERALL DIMENSIONS**, refer to the illustration and chart below.

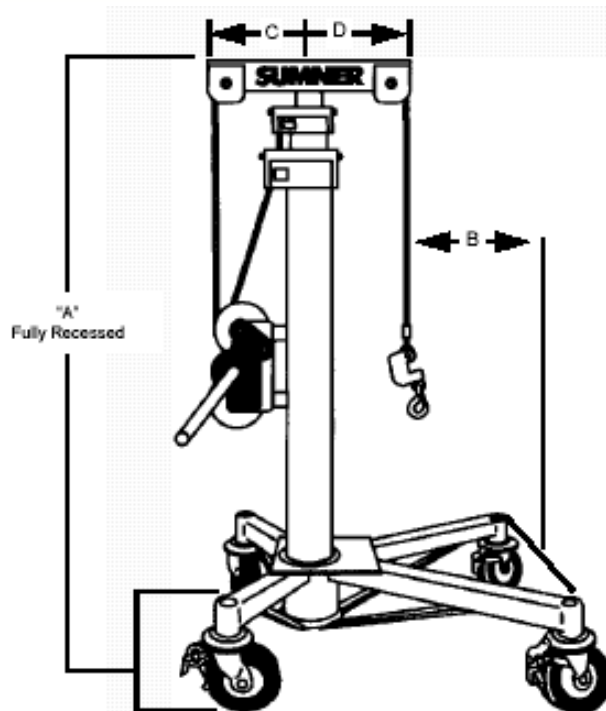

Model	A	B	C	D	Base Dimensions	Shipping Wt.
R-100	79" 200 cm	20" 50 cm	12" 30 cm	12" 30 cm	32 x 40 80 x 100 cm	311 lb 140 kg
R-150	79" 200 cm	20" 50 cm	12" 30 cm	12" 30 cm	40 x 40 100 x 100 cm	311 lb 140 kg
R-180	126" 320 cm	25" 63 cm	14.5" 36 cm	14.5" 36 cm	50 x 50 125 x 125 cm	337 lb 153 kg
R-250	119" 302 cm	30" 75 cm	17.5" 44 cm	17.5" 44 cm	60 x 60 150 x 150 cm	381 lb 170 kg

ASSEMBLY INSTRUCTIONS

1. Turn base upside down.
2. Insert the four casters into the base legs.
3. Secure the casters into the base by installing the four supplied setscrews into the base legs and then tighten with allen wrench. Ensure screw is tightened onto caster stem.
4. Turn base over and lock caster brakes.
5. Insert mast assembly into base assembly socket with winch to rear of base, rear being the side of base with the shorter legs.
6. Ensure base latch is engaged.
7. Release tension on lifting cable by turning the lower shaft on the winch counterclockwise. Remove clevis pin and clevis. Now lower the lift cable so end of cable can be reached by operator.
8. Attach counterweight and line shackle directly to loop on end of lift cable.

OPERATING PROCEDURE



WARNING

Operators should be thoroughly familiar with the preceding safety precautions before attempting to operate this equipment.

NOTE: Always lower mast assembly to the lowest possible position prior to moving unit.

1. MOVING ROUST-A-BOUT TO WORK AREA (NO LOAD)

1. The load line shackle should be attached to winch mount bracket prior to transporting unit to prevent the cable from swinging and striking operator or bystanders.
2. Attach winch handles to both sides of winch, which will allow them to be used as a handlebar to steer the unit.

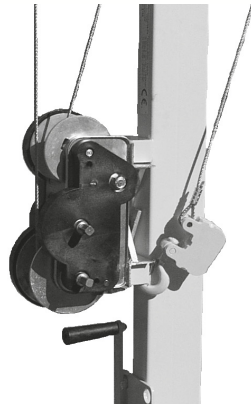

3. Release caster brakes.
4. Grasp winch handles and make a forward "S" motion to align casters for forward movement to work area.



WARNING

Roust-a-Bout should only be operated on level and smooth surfaces to avoid tipping and possibility of operator injury.

2. MOVING ROUST-A-BOUT TO WORK AREA (WITH LOAD)

1. When the Roust-A-Bout is used to transport a load, the load should be placed on the base legs for positive control of the lift.
2. The loaded Roust-A-Bout should only be moved in the forward direction, whenever possible.
3. Repeat steps 2, 3 and 4 from previous section.

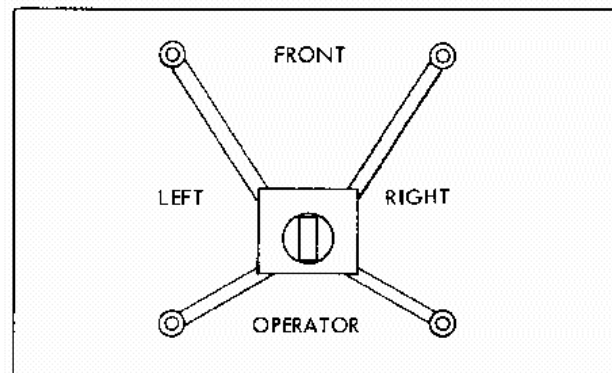

3. Elevating Mast

NOTE: Mast should be elevated to required height prior to lifting any load over 500 lb (225 kg).



WARNING

"Guy Lines" must be used anytime mast is elevated over 20 ft (6.1 m)

3. Elevating Mast (continued)

1. Turn handle on left side of winch counterclockwise to elevate.

2. Never allow lift cable loop, Counter Weight, or line shackle to contact "Tee Head" while elevating mast. Continued cranking in this condition will cause "Tee Head" to bend.

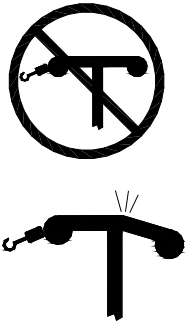

NOTE: A red line will appear on the center mast as a warning to use "Guy Lines" on the R-250.

See page 10 for "Guy Line" assembly instructions.

4. Attaching Lift Cable to Object

1. With mast elevated, lower lift line to load by pushing up, and holding, the Free Fall Lever (located on the left side of the winch).

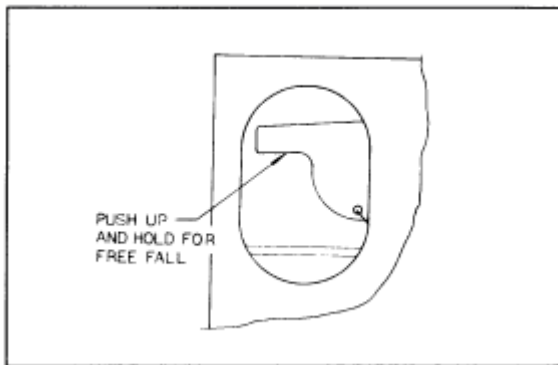

WARNING

Never attempt to use free fall lever with a load attached.

2. While holding up Free Fall Lever, pull cable from lower spool of winch, as shown, until the cable is long enough to securely attach to the load.

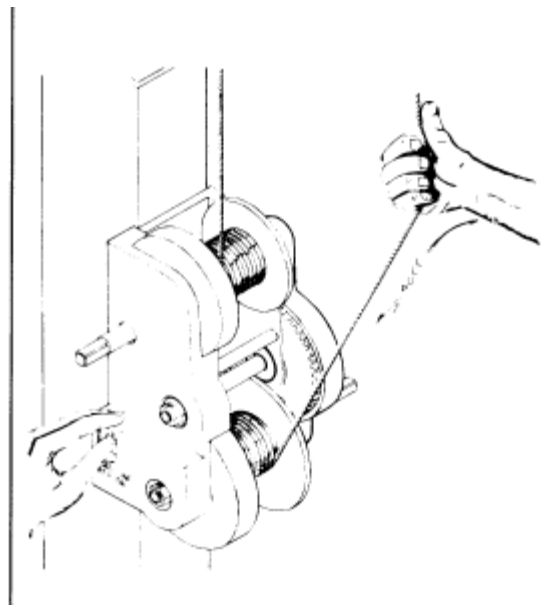

Note: Secure load line using approved rigging practices and equipment only.



WARNING

Always lift load slightly to check rigging and balance before elevating.

Note: Stabilizing lines should be used to control any long or awkward load. Use as many lines as necessary to maintain complete control of the suspended object.

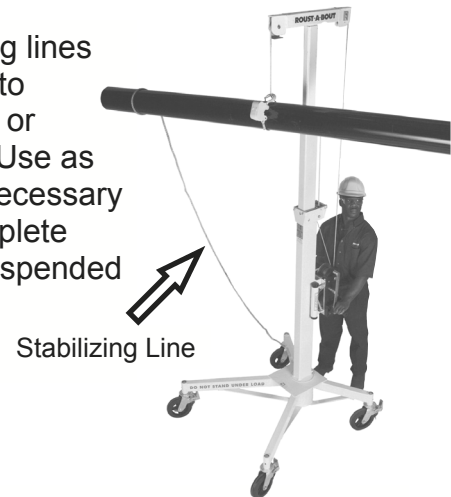

5. Elevating Load

1. Select the proper shaft and winch handle socket for lifting in accordance with the weight chart below.
2. Raise the load by turning the winch handle in a clockwise direction.



WARNING

Never allow anyone under an elevated load.

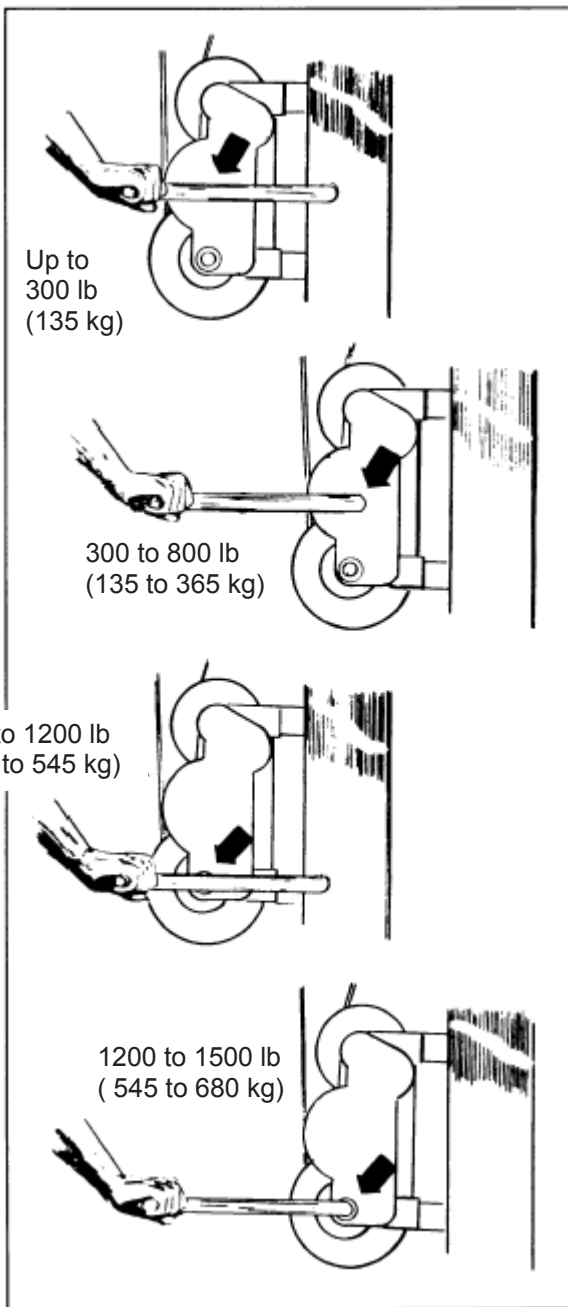

6. Lowering Load

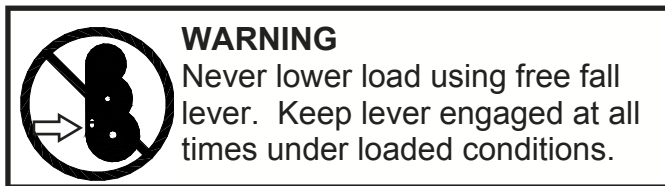

1. Load can only be lowered by using the lower shaft on the right side of the winch.

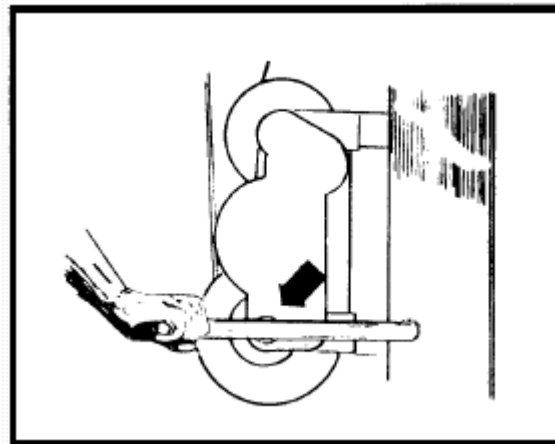

2. Insert either socket on winch handle onto lower shaft and turn handle counterclockwise to lower load.

7. Lowering Mast

Note: Mast should be lowered with no load whenever possible, and should never be lowered with a load exceeding 500 lb (225 kg) attached.

1. Install winch handle onto lower shaft on left side of winch.
2. Lower mast by turning handle in a clockwise direction.

8. Removing Mast

Note: Caster brakes should always be locked when removing mast.

1. Release base latch by pulling ring and turning. Make sure ring is not engaged in housing slot.
2. Place crowbar under pry tab and raise mast from base until the locating ring rests on top of the base.
3. Remove mast from the base.

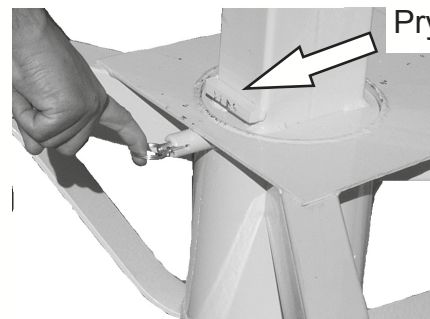

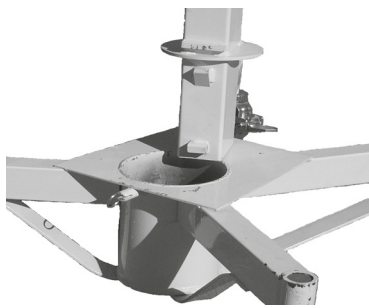

9. Caster Brakes

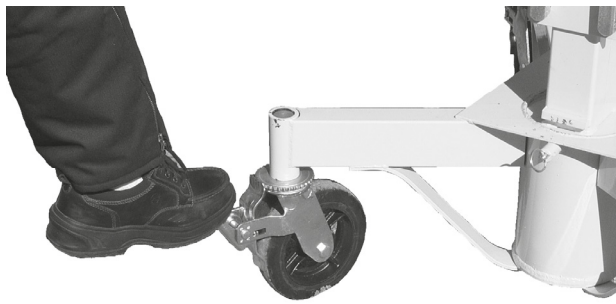

1. Set brake by pressing down on brake lever as shown.
2. Release brake by lifting up on brake lever.

10. Handle Storage

When not in use, the Roust-A-Bout handles should be kept in the storage location.

1. To store handles, align the sockets with the holes in the storage plate.
2. Slide handle in until it contacts the spring loaded pin.
3. Press in spring loaded pin and continue to slide in handle.
4. Reverse steps 1 thru 3 to remove.



11. Shear Pin

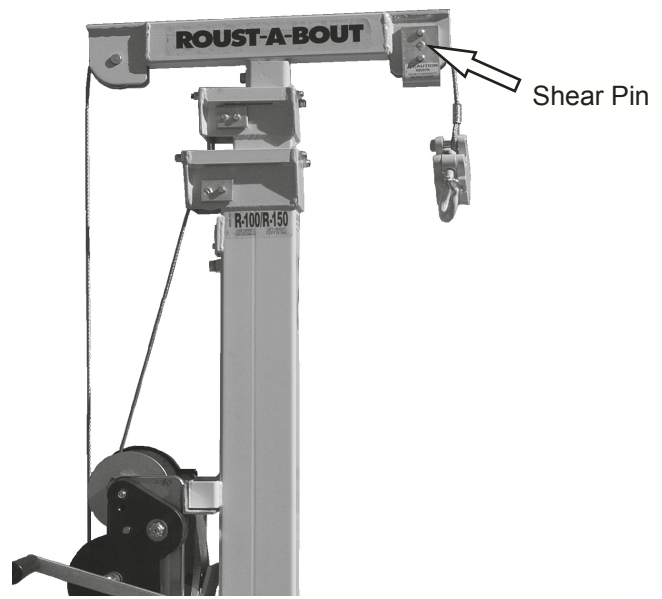

Note: All R-Series Roust-A-Bouts contain a safety device known as a Shear Pin. This pin is located on the front sheave of the “Tee Head”. The purpose of the pin is to protect the lift in the event of an overload. A spare Shear Pin is located underneath the Winch Assembly.

12. Options

Tee Head Extension Bar



Note: Allows handling of bulky loads. Advise Model No. when ordering.

WARNING

Load center is only 4” (10 cm) behind centerline of front casters. This lessens the stability of the lift and should only be used when handling bulky loads.

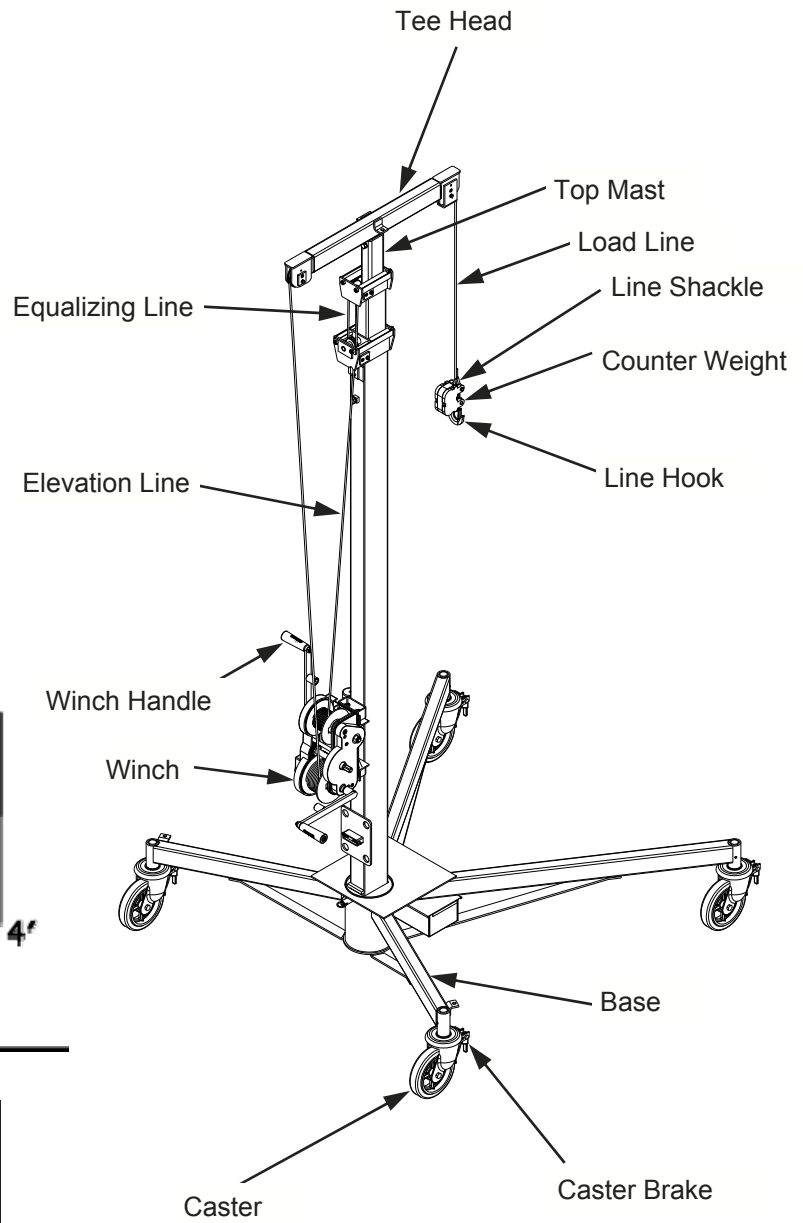
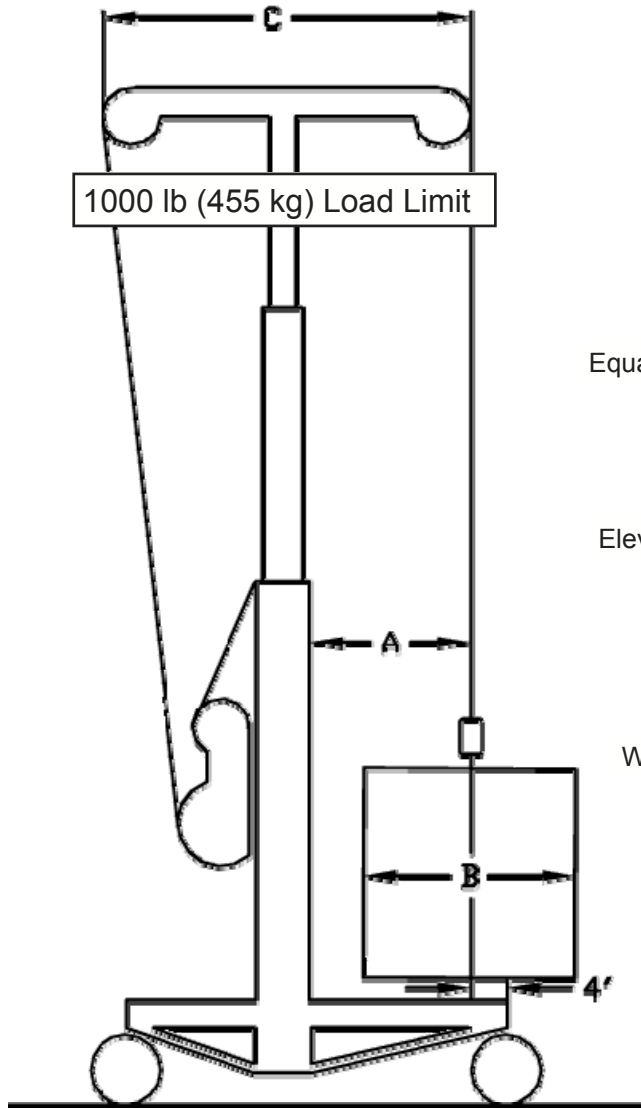

Model	A	B	C
R-100	22" (55 cm)	43" (108 cm)	48" (120 cm)
R-150	22" (55 cm)	43" (108 cm)	48" (120 cm)
R-180	29" (73 cm)	58" (145 cm)	63" (158 cm)
R-250	37" (93 cm)	73" (183 cm)	78" (195 cm)

13. Guy Lines

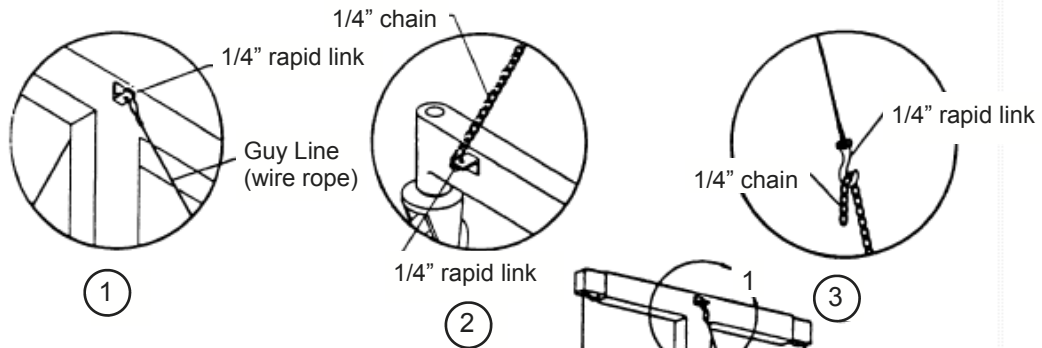



IMPORTANT
Read before operating
Roust-A-Bout

When working the R-250 above 20 ft (6.1 m), a red line will show on the Center Mast as a warning to use Guy Lines.

1. Attach two wire ropes to Top Mast before elevating mast.
2. Attach two 1/4" chains to rear legs.
3. Elevate mast to about 10 to 12" (25 to 30 cm) lower than the desired work height.
4. Attach chains to wire rope, ensuring that Guy Lines are of equal length.
5. Elevate mast until Guy Lines are taut.

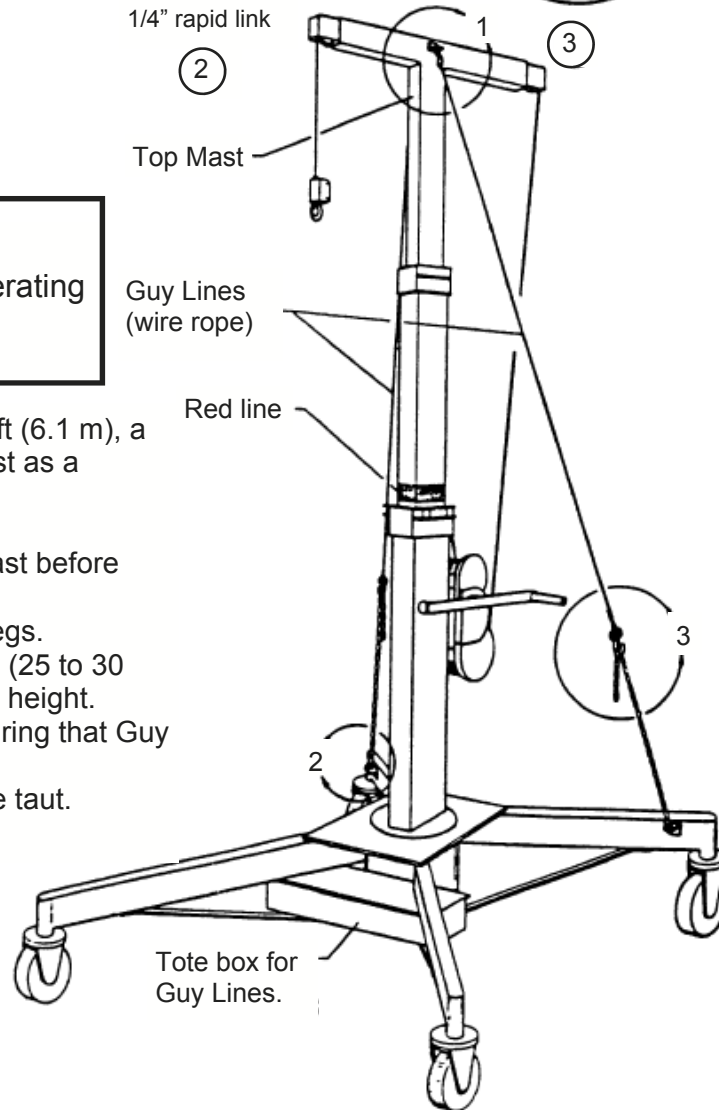

MAINTENANCE INSTRUCTIONS

Before each use:

1. Inspect the cable for kinks and frays. If kinked or more than 3 wire strands are broken (small wires) do not use the lift until the cable has been replaced.
2. Make certain winch operates freely and cable is not tangled on the winch drum.
3. Inspect masts, legs, and base for bends.
4. Make sure caster wheels move freely.

Recommended Inspection Every 6 Months:

1. Inspect cable for frays and kinks (see point 1 above)
2. Make certain winch works freely and that there are no loose or damaged parts.

Winch Maintenance:

1. Refer to the winch assembly drawings in this Operators Manual.
2. Be sure that both winch covers are on the winch.
3. Check ratchet dog and brake ratchet for wear. If any wear is visible, replace the part.
4. Inspect gear teeth for wear. If there is no sign of visible wear, brush teeth with 50-wt. Motor oil.
5. For proper brake adjustment see "Troubleshooting" section on page 12.

Replacing the Cables:

A. Load Lifting Line

1. Lay Roust-A-Bout across supports with the winch facing up.
2. Remove both gear covers.
3. Disengage load ratchet dog and pull wire rope off of large drum.
4. Loosen set screw on drum and pull wire rope out of keeper.
5. Pull Load Line out through front of Tee head.
6. Reverse for installing new Load Line.

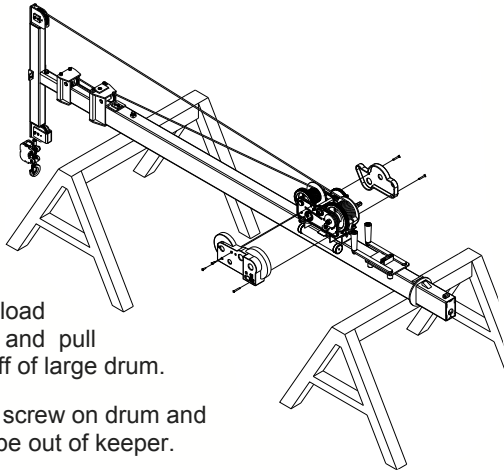

B. Mast Elevating Line

1. Lay Roust-A-Bout across supports with the winch facing up.
2. Remove both gear covers
3. Remove in sequence item numbers 17, 10, 11 and 12.

4. Remove in sequence item numbers 13, 6, 7, 8 and 9.

5. Remove in sequence item numbers 18, 16, 5, 3 and 4.

6. Remove in sequence item numbers 18, 16, 2 and 3.

7. Remove Center Mast.

8. Remove keeper wire and old Elevating Line. Note direction of reeve.

9. Reverse steps 1 thru 8 to install new line.

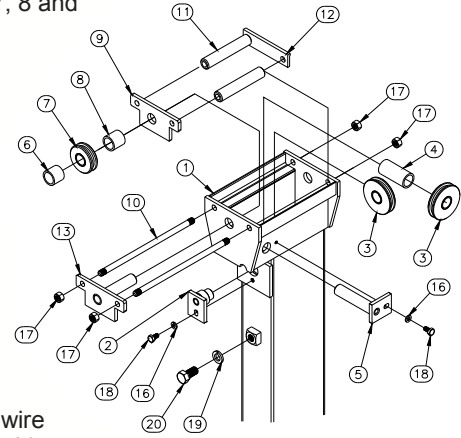

C. Equalizing Line

1. Remove in sequence item numbers 10, 3, 2 and 4.

2. Remove in sequence item numbers 8, 9, 5, 6 and 7.

3. Remove Top Mast.

4. Remove keeper wire and old Equalizing Line. Note direction of reeve.

5. Reverse steps 1 thru 8 to install new line.

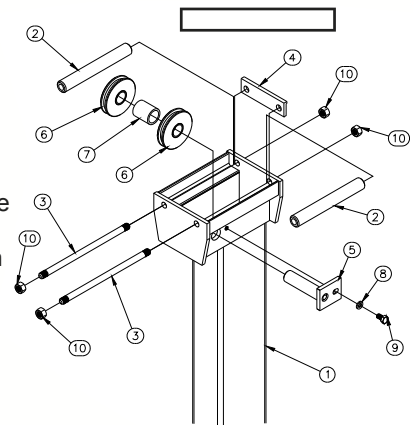

General Maintenance:

1. Check both winch handles for wear or bends.
2. Examine all bolts and nuts to be sure they are tight.
3. Legs, braces and base should be dent free and damage free.
4. Check pulley housings for damage (indentations) which can restrict the rotation of the pulleys.
5. Make sure all lines are seated in all pulleys and that pulleys rotate without obstruction.
6. Check all rollers for free rotation.
7. Raise mast sections to inspect for free, smooth sliding action. Make sure wire slide ways are free of dust and oxidation and spray a light coat of silicone lubrication in slide ways.
8. Make sure caster wheels rotate freely and are undamaged.

**WARNING**

Modifying the Roust-A-Bout in any way can cause injury or death!

**WARNING**

Replace all worn or damage parts only with Sumner parts.

TROUBLESHOOTING

PROBLEM	CAUSE	SOLUTION
Masts not rising	Trying to lift more than 500 lb (225 kg) by elevating the masts.	Remove load, elevate the masts to the desired height, raise load.
	Mast rollers not rotating. Inspect for debris or any foreign obstruction	Clean roller shafts with a degreaser or brake cleaner and lubricate with a silicon lubricant
	Cable pulley wheel not rotating	If there is any damage to the pulley wheel, or if the wheel doesn't rotate smoothly, change wheel.
	Inspect cable for damage	If cable is kinked, worn or frayed, replace cable
	Inspect mast sections for damage	Replace damaged mast section
If none of these solutions seem to fix the problem...		Call distributor's Customer Service Department

PROBLEM	CAUSE	SOLUTION
Roust-A-Bout not holding the load.	Winch Brakes need adjusting.	See below
	Brake pads are worn.	Replace Brake pads.
	Ratchet Dog or Brake Ratchet are worn.	Replace the Ratchet Dog and/or Brake Ratchet
	Ratchet Spring is broken or worn.	Replace the Brake Ratchet Spring.

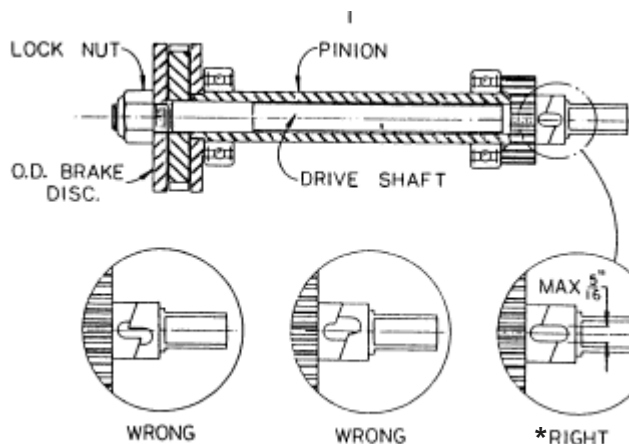
**Important**

The information below applies to both Load Drum and Hoist Drum Drive Shafts.

For proper adjustment on the CS2000 winch, the pinion and drive shaft must be in position shown when lock nut is tightened against O.D. Brake Disc. The lock nut should be torqued to 15 ft lb.

*Correct alignment is only visible when load is applied to lift.

MAINTENANCE RECORD

Lift Model Number _____

Lift Serial Number _____

Service Performed:

_____ Date

_____ Date

_____ Date

_____ Date

_____ Date

_____ Date

_____ Date

_____ Date

_____ Date

_____ Date

_____ Date

_____ Date

_____ Date

© 2013 Sumner Manufacturing Company, Inc.