



IMPORTANT INFORMATION:

- A copy of our “Safe Operating Practices” Manuals are always available free of charge either by downloading it from our Technical Publications website @ www.airwinch.com or by contacting the Factory at (800) 866-5457 for North America and (206) 624-0466 for International. The Safe Operating Practices manual must be read prior to anyone operating a **Ingersoll-Rand** winch or hoist. The manual form numbers are as follows:

“Safe Operating Practices Non-Man Rider™ Winches” Manual, Form No. MHD56250

“Safe Operating Practices for Man Rider™ Winches” Manual, Form No. MHD56251

“Safe Operating Practices for Pneumatic, Hydraulic and Electric Hoists” Manual, Form No. MHD56295

- Available winch options may require additional supplements to the basic winch manual.
- For Man Rider™ winches ensure a copy of the Man Rider™ supplement is made available to the operator prior to winch operation.

Winch Man Rider™ Supplements:

Model:	Publication No.
FA2, FA2.5, FH2, FH2.5	MHD56046
FA5	MHD56042 and MHD56220
FA10	MHD56252
FA2.5A	MHD56236
FA2B and HU40A	MHD56207
FH10MR	MHD56212
Fulcrum Electric	MHD56277
LS500HLP/ LS1000HLP	SAM0004

Model:	Publication No.
LS500RLP	SAM0011
LS1000RLP	SAM0012
LS150RLP	SAM0082
LS150RLP/500/ 1000	SAM0115
LS150RLP and LS150PLP-PH	SAM0120
LS500RLP-E	SAM0122
LS150RLP- DP5M-F	SAM0184
LS150HLP	SAM0222

- We strongly recommend that ALL maintenance on **Ingersoll-Rand** equipment be carried out by personnel certified by **Ingersoll-Rand**, or by **Ingersoll-Rand** Authorized Service Centers.
- Contact the Factory if in doubt about installation, operation, inspection and maintenance instructions.
- Use only Genuine **Ingersoll-Rand** parts when maintaining or repairing a winch, hoist or any component of a winch or hoist.
- ANSI / ASME recommends that a winch or hoist (or any components of a winch or hoist) that has been repaired be tested prior to being placed into service:
 - * **Winches** - ANSI / ASME B30.7 (BASE MOUNTED DRUM HOISTS) Refer to section 7.2.2 - Testing.
 - * **Hoists** - ANSI / ASME B30.16 (OVERHEAD HOISTS - UNDERHUNG) Refer to section 16.2.2 - Testing.

Form MHD56298

Edition 2

November 2004

71441844

© 2004 Ingersoll-Rand Company





Form MHD56177

PARTS, OPERATION AND MAINTENANCE MANUAL FOURTH GENERATION

force **5**TM **MODULAR WINCHES**

MODELS

FA2B

HU40A

AMP94A

FH2B

FE2B

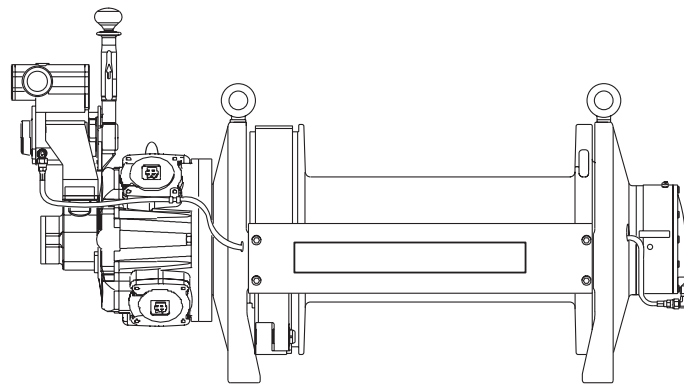
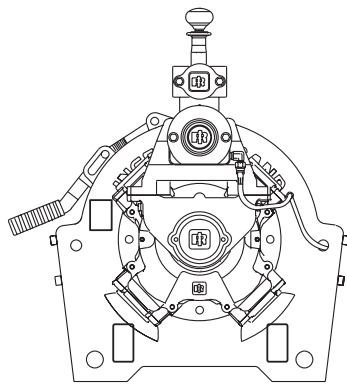

(Dwg. MHP1838)

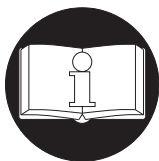

READ THIS MANUAL BEFORE USING THESE PRODUCTS. This manual contains important safety, installation, operation and maintenance information. Make this manual available to all persons responsible for the operation, installation and maintenance of these products.

⚠ WARNING

Do not use this winch for lifting, supporting, or transporting people unless winch is approved for Man Rider® applications. Do not lift or support loads over people.

Always operate, inspect and maintain this winch in accordance with American National Standards Institute Safety Code (ASME B30.7) and any other applicable safety codes and regulations.

Refer all communications to the nearest Ingersoll-Rand Material Handling Office or Distributor.

Form MHD56177

Edition 1

April 1999

71347758

© 1999 Ingersoll-Rand Company

INGERSOLL-RAND
MATERIAL HANDLING

CONTENTS

Description	Page No.	
Safety Information		
Danger, Caution, Warning and Notice	3	
Safe Operating Instructions	4	
Warning Labels and Tag	4	
Specifications		
Description	5	
Model Code Explanation	6	
General Specifications	7	
Winch Weight	7	
Wire Rope Capacities	8	
Rated Performance Graphs	8	
Installation		
Mounting	10	
Wire Rope	11	
Air Supply	12	
Initial Operating Checks	14	
Operation		
Air Motor	14	
Winch Controls	15	
Brakes	17	
Free Spool	17	
Inspection		
Records and Reports	18	
Wire Rope Report	18	
Frequent Inspection	19	
Periodic Inspection	19	
Winches Not in Regular Use	20	
Inspection and Maintenance Report Form	21	
Troubleshooting		22
Lubrication		24
Maintenance		
Thermoplastic Coating	27	
Adjustments	28	
Disassembly	28	
Cleaning, Inspection and Repair	33	
Assembly	34	
Testing	40	
Parts Section		
Winch Cross Section Drawing	41	
Winch Parts Drawings and Traceability	41	
Winch Parts Drawings and Parts Lists	42 - 69	
Parts Ordering Information	70	
Warranty		71
Office Locations		72

SAFETY INFORMATION

This manual provides important information for all personnel involved with the safe installation, operation and proper maintenance of this product. Even if you feel you are familiar with this or similar equipment, you should read this manual before operating the winch.

Danger, Warning, Caution and Notice

Throughout this manual there are steps and procedures which, if not followed, may result in a hazard. The following signal words are used to identify the level of potential hazard.

DANGER

Danger is used to indicate the presence of a hazard which **will** cause **severe** injury, death, or substantial property damage if the warning is ignored.

WARNING

Warning is used to indicate the presence of a hazard which **can** cause **severe** injury, death, or substantial property damage if the warning is ignored.

CAUTION

Caution is used to indicate the presence of a hazard which **will** or **can** cause injury or property damage if the warning is ignored.

NOTICE

Notice is used to notify people of installation, operation, or maintenance information which is important but not hazard-related.

Safety Summary

WARNING

- **Do not use this winch for lifting, supporting, or transporting people unless winch is approved for Man Rider® applications. Do not lift or support loads over people.**
- **The supporting structures and load-attaching devices used in conjunction with this winch must provide an adequate safety factor to handle the rated load, plus the weight of the winch and attached equipment. This is the customer's responsibility. If in doubt, consult a registered structural engineer.**

Ingersoll-Rand Material Handling winches are manufactured in accordance with the latest ASME B30.7 standards.

The National Safety Council, Accident Prevention Manual for Industrial Operations, Eighth Edition and other recognized safety sources make a common point: Employees who work near suspended loads or assist in hooking on or arranging a load should be instructed to keep out from under the load. From a safety standpoint, one factor is paramount: conduct all lifting or pulling operations in such a manner that if there were an equipment failure, no personnel would be injured. This means keep out from under a raised load and keep out of the intended path of any load.

The Occupational Safety and Health Act of 1970 generally places the burden of compliance with the user, not the manufacturer. Many OSHA requirements are not concerned or connected with the manufactured product but are, rather, associated with the final installation. It is the owner's and user's responsibility to determine the suitability of a product for any particular use. It is recommended that all applicable industry, trade association, federal, state and local regulations be checked. Read all operating instructions and warnings before operation.

Rigging: It is the responsibility of the operator to exercise caution, use common sense and be familiar with proper rigging techniques. Refer to ASME B30.9 for rigging information, American National Standards Institute, 1430 Broadway, New York, NY 10018.

This manual has been produced by **Ingersoll-Rand** to provide dealers, mechanics, operators and company personnel with information required to install, operate, maintain and repair the products described herein.

It is extremely important that mechanics and operators be familiar with servicing procedures of these products, or like or similar products, and are physically capable of conducting the procedures. These personnel shall have a general working knowledge that includes:

1. Proper and safe use and application of mechanics common hand tools as well as special **Ingersoll-Rand** or recommended tools.
2. Safety procedures, precautions and work habits established by accepted industry standards.

Ingersoll-Rand cannot know of, or provide all the procedures by which product operations or repairs may be conducted and the hazards and/or results of each method. If operation or maintenance procedures not specifically recommended by the manufacturer are conducted, it must be ensured that product safety is not endangered by the actions taken. If unsure of an operation or maintenance procedure or step, personnel should place the product in a safe condition and contact supervisors and/or the factory for technical assistance.

SAFE OPERATING INSTRUCTIONS

The following warnings and operating instructions have been adapted in part from American National (Safety) Standard ASME B30.7 and are intended to avoid unsafe operating practices which might lead to injury or property damage.

Ingersoll-Rand recognizes that most companies who use winches have a safety program in force at their facility. In the event that some conflict exists between a rule set forth in this publication and a similar rule already set by an individual company, the more stringent of the two should take precedence.

Safe Operating Instructions are provided to make an operator aware of dangerous practices to avoid and are not necessarily limited to the following list. Refer to specific sections in the manual for additional safety information.

1. Only allow people, trained in safety and operation of this product, to operate and maintain this winch.
2. Only operate a winch if you are physically fit to do so.
3. When a “**DO NOT OPERATE**” sign is placed on the winch, or controls, do not operate the winch until the sign has been removed by designated personnel.
4. Before each shift, the operator should inspect the winch for wear and damage. Never use a winch that inspection indicates is worn or damaged.
5. Never lift a load greater than the rated capacity of the winch. Refer to nameplate attached to winch and to “**SPECIFICATIONS**” section.
6. Keep hands, clothing, etc., clear of moving parts.
7. Never place your hand in the throat area of a hook or near wire rope spooling onto or off of the winch drum.
8. Always rig loads properly and carefully.
9. Be certain the load is properly seated in the saddle of the hook. Do not support the load on the tip of the hook.
10. Do not “side pull” or “yard”.
11. Always ensure that you, and all other people, are clear of the path of the load. Do not lift a load over people.
12. Do not use this winch for lifting, supporting, or transporting people unless winch is approved for Man Rider® applications. Do not lift or support loads over people.
13. Ease the slack out of the wire rope when starting a lift or pull. Do not jerk the load.
14. Do not swing a suspended load.
15. Do not leave a suspended load unattended.
16. Never operate a winch with twisted, kinked or damaged wire rope.
17. Pay attention to the load at all times when operating the winch.
18. Never use the wire rope as a sling.
19. After use, or when in a non-operational mode, the winch should be secured against unauthorized and unwarranted use.

WARNING LABELS AND TAG

Each unit is shipped from the factory with the warning labels and tag shown. If the labels or tag are not attached to your unit, order new labels and tag and install. Refer to the parts list for the part numbers. Labels and tag shown smaller than actual size.
 Note: Label 04306445 and 71056410 are not used on Man Rider® approved winches. Refer to Man Rider® literature for applicable labels.

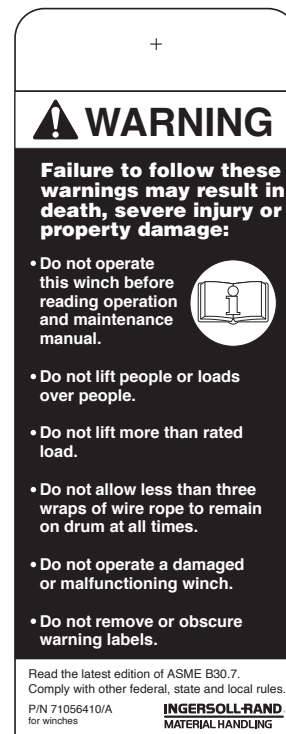

SPECIFICATIONS

Description

Winches can be powered by any of three power supplies: Air Motor, Hydraulic Motor or Electric Motor. These power supplies, coupled with a planetary reduction gearbox, are designed for lifting and pulling applications. Winches are supplied with either an internal automatic disc brake, a manual or automatic externally mounted drum band brake, or a combination of both.

The output from an externally mounted power supply is transmitted through a coupling and shaft to the planetary reduction gear assembly.













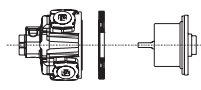
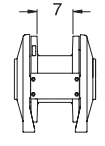

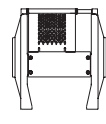
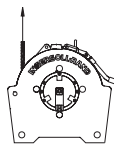
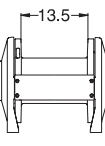
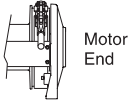

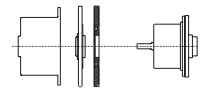
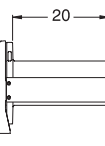
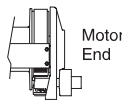

The output from the planetary reduction gear assembly is connected to the wire rope drum through the output shaft.

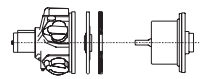
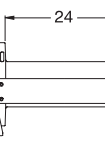
The disc brake attaches to the outboard upright opposite the motor end and is connected to the intermediate sun gear through the brake shaft. The disc brake is automatically applied when the winch is in neutral or operated in the haul-in position. It is disengaged when the winch is operated in the payout direction.

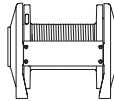
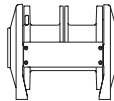
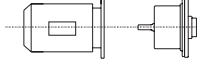
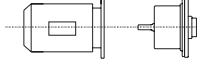
During winch operation a sprag-type clutch in the disc brake allows drum rotation in the haul-in direction with the disc brake engaged. This ensures the brake will respond quickly to hold the load when winch operation stops. Operation of the winch in the payout direction energizes the disc brake to overcome spring tension and release the brake. When payout operation is complete, disc brake is de-energized and the brake is automatically applied.

The drum band brake operates by applying a friction force between the brake band and the winch drum. The manual brake requires an operator to engage and disengage the brake using a handle located near the air motor end of the winch. The automatic drum band brake operation is similar to the disc brake with the following exception: the automatic drum band brake fully disengages in both the haul-in and payout directions.

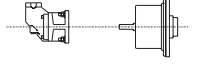
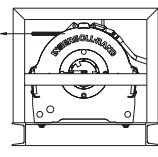
Model Matrix (refer to Model Code Explanation on page 6 for complete list of options):

Controls	Motor/Gearbox	Drum Sizes	Brakes	Options
AIR				
 Winch Mounted Lever Throttle	 Remote Full Flow Lever Throttle	 Motor: MP150 Gearbox: 39:1	 Short (S)	 Disc Brake (K) (Available in Air, Electric or Hydraulic)
 Drum Guard (G)	 Underwound (U)	 Medium (M)	 Motor End Manual Drum Brake (M)	 Free Spool (F)
 Remote Pilot Pendant Throttle	 Remote Pilot Lever Throttle	 Motor: HU40 Gearbox: 39:1	 Long (L)	 Motor End Auto Drum Brake (A) (Currently Air Only)
 -E Throttle	 -E Pilot Pendant	 Motor: AMP94 Gearbox: 39:1	 Extra Long (R)	 Open Front (H)
 Drum Grooving	 Drum Divider Flange (D)	ELECTRIC		
Reversing Drum Switch NEMA 1 (D1)	 Reversing Drum Switch NEMA 4 (D4)	 Motor: 15 HP Electric Gearbox: 39:1	HYDRAULIC	
Wall Mount NEMA 4 (W4)	 Pendant NEMA 3R (P3)	 Winch Mounted Lever Throttle		
Pendant NEMA 4 (P4)	 Remote Full Flow Lever Throttle	 Motor Displacement: 3.65 CIR (cubic inches per revolution) Gearbox: 39:1		
 Cage (E)				
 Tensioning Manifold (Not Electric)				

(Dwg. MHP1849)

Model Code Explanation

Example: FA2B-LXXK1G-E

FA2B - L X K 1 G -E

Series (Capacity and Generation)

- FA2B = 2 ton Air Powered Winch (4,000 lbs/1814 kgs.)
- FH2B = 2 ton Hydraulic Powered Winch (4,000 lbs/1814 kgs.)
- FE2B = 2 ton Electric Powered Winch (4,000 lbs/1814 kgs.)
- HU40A = 2 ton Air Powered Winch with HU40A Motor (4,000 lbs/1814 kgs.)
- AMP94A = 2 ton Air Powered Winch with AMP94A Motor (4,000 lbs/1814 kgs.)

Drum Length:

- S = Short - 7 inches (178 mm)
- M = Medium - 13-1/2 inches (343 mm)
- L = **Long - 20 inches (508 mm)**
- R = Extra long - 24 inches (610 mm)

Drum Brake:

- A = Automatic Drum Brake
- M = Manual Drum Brake
- X = **None**

Disc Brake:

- K = **Automatic Disc Brake**
- X = None

Control:

- 1 = **Winch mounted lever throttle. (Standard)**
- 2 = Remote full flow lever throttle with standard 6 foot (2 metres) length hose
- 2XX = Remote full flow lever throttle (XX = Specify hose length (feet). Maximum 20 ft. (6 metres))
- 3XX = Remote pilot pendant throttle (XX = Specify hose length (feet). Maximum 50 ft. (15 metres))
- 4XX = Remote pilot lever throttle (XX = Specify hose length (feet). Maximum 50 ft. (15 metres))

Options:

- 7 = Drum Grooving (Number = wire rope size in sixteenths, e.g. 7/16 inch) *
- ** C = Low Temperature Components; specify -10° C (14° F) or -20° C (-4° F)
- D = Drum Divider Flange and additional wire rope anchor *
- E = Enclosed Cage *
- F = Free Spool clutch (available only with manual drum brake)
- G = **Drum Guard**
- H = Open Front (Frame) for horizontal pulling
- L = Drum Locking Pin
- N = Type Approval – Specify:
A = American Bureau of Shipping (ABS); N = Det Norske Veritas (DNV); R = Lloyd’s Register of Shipping (LRS)
- Q = Special Paint
- ** M1 = Material Traceability (Typical material results)
- ** M2 = Material Traceability (Actual material results)
- ** M3 = Material Traceability (Actual material results for these parts in finished, as-delivered condition)
- R = Suitable for operation with Natural Gas with up to 4% sulphur content
- T = Tensioning Manifold *
- U = Underwound wire rope operation *
- ** W = Witness; please specify
- X = Testing; please specify
- E = **Compliance with European Machinery Directive (includes Emergency Stop and Overload Protection)**

Notes:

- * Not covered in this manual. Contact the factory or your nearest **Ingersoll-Rand** distributor for information.
- ** Documentation, witness testing and material traceability available; must be requested at time of order. Specify options or contact the factory or your nearest **Ingersoll-Rand** distributor for information.

General Specifications (Air Winches)

Air Motor Pipe Inlet Size	1-1/4 inch NPT	
Minimum Air System Hose Size	1.25 inch	32 mm
Drum Barrel Diameter	9.25 inches	235 mm
Drum Flange Diameter	17 inches	432 mm
Wire Rope Diameter	3/8-5/8 inches	10-16 mm

General Specifications - Air Winch Motors

		Motor Model							
		FA2B (425 scfm air supply)				FA2B (185 scfm air supply)			
Air System	Rated Operating Pressure	90 psig (6.3 bar/630 kPa)							
	Air Consumption (at rated pressure and load)	425 scfm		12 cu.m/min		185 scfm		4 cu. m/min	
Rated Performance (at rated pressure/volume)		Lifting (5:1 design factor)		Pulling (3.5:1 design factor)		Lifting (5:1 design factor)		Pulling (3.5:1 design factor)	
1st Layer	Rated Load	5170* lbs	2345 kg	7360* lbs	3338 kg	5170* lbs	2345 kg	5200** lbs	2359 kg
	Rated Speed	80 fpm	24 m/min	18 fpm	5 m/min	39 fpm	12 m/min	36 fpm	11 m/min
Mid Layer	Rated Load	4000 lbs	1814 kg	5700 lbs	2585 kg	4000 lbs	1814 kg	4000** lbs	1814 kg
	Rated Speed	104 fpm	32 m/min	24 fpm	7 m/min	50 fpm	15 m/min	50 fpm	15 m/min
Top Layer	Rated Load	3260 lbs	1479 kg	4600 lbs	2086 kg	3260 lbs	1479 kg	3260** lbs	1479 kg
	Rated Speed	127 fpm	39 m/min	29 fpm	9 m/min	62 fpm	19 m/min	62 fpm	19 m/min
Motor Horsepower (HP)		17				12			

		Motor Model							
		AMP94A (320 scfm air supply)				HU40A (300 scfm air supply)			
Air System	Rated Operating Pressure	90 psig (6.3 bar/630 kPa)							
	Air Consumption (at rated pressure and load)	320 scfm		9.1 cu. m/min		300 scfm		8.5 cu. m/min	
Rated Performance (at rated pressure/volume)		Lifting (5:1 design factor)		Pulling (3.5:1 design factor)		Lifting (5:1 design factor)		Pulling (3.5:1 design factor)	
1st Layer	Rated Load	5170* lbs	2345 kg	5815* lbs	2638 kg	5170* lbs	2345 kg	7360* lbs	3338 kg
	Rated Speed	36 fpm	11 m/min	15 fpm	5 m/min	54 fpm	16 m/min	38 fpm	12 m/min
Mid Layer	Rated Load	4000 lbs	1814 kg	4500 lbs	2041 kg	4000 lbs	1814 kg	5700 lbs	2585 kg
	Rated Speed	46 fpm	14 m/min	19 fpm	6 m/min	70 fpm	21 m/min	49 fpm	15 m/min
Top Layer	Rated Load	3260 lbs	1479 kg	3670 lbs	1665 kg	3260 lbs	1479 kg	4600 lbs	2086 kg
	Rated Speed	56 fpm	17 m/min	24 fpm	7 m/min	86 fpm	26 m/min	60 fpm	18 m/min
Motor Horsepower (HP)		9.4				11			

* Operating winch at these loads exceeds ASME B30.7 lifting and/or pulling guidelines.

** Limited by available motor torque.

FA2B Winch Weights (without wire rope)

Model	lbs	kg	Model	lbs	kg	Model	lbs	kg	Model	lbs	kg
FA2B-SXK1	545	247	FA2B-SXK2	550	249	FA2B-LXK1	625	284	FA2B-LXK2	630	286
FA2B-SMK1	605	274	FA2B-SMK2	610	277	FA2B-LMK1	685	311	FA2B-LMK2	590	268
FA2B-SAK1	625	283	FA2B-SAK2	630	286	FA2B-LAK1	705	320	FA2B-LAK2	710	322
FA2B-SMX1	570	259	N/A			FA2B-LMX1	650	295	N/A		
FA2B-SAX1	590	268	FA2B-SAX2	595	270	FA2B-LAX1	670	304	FA2B-LAX2	675	306
FA2B-MXK1	585	265	FA2B-MXK2	590	268	FA2B-RXK1	655	297	FA2B-RXK2	660	299
FA2B-MMK1	645	293	FA2B-MMK2	650	295	FA2B-RMK1	715	324	FA2B-RMK2	720	327
FA2B-MAK1	665	302	FA2B-MAK2	670	304	FA2B-RAK1	735	333	FA2B-RAK2	740	336
FA2B-MMX1	610	277	N/A			FA2B-RMX1	680	308	N/A		
FA2B-MAX1	630	286	FA2B-MAX2	635	288	FA2B-RAX1	700	318	FA2B-RAX2	705	320

Rated Performance Graphs

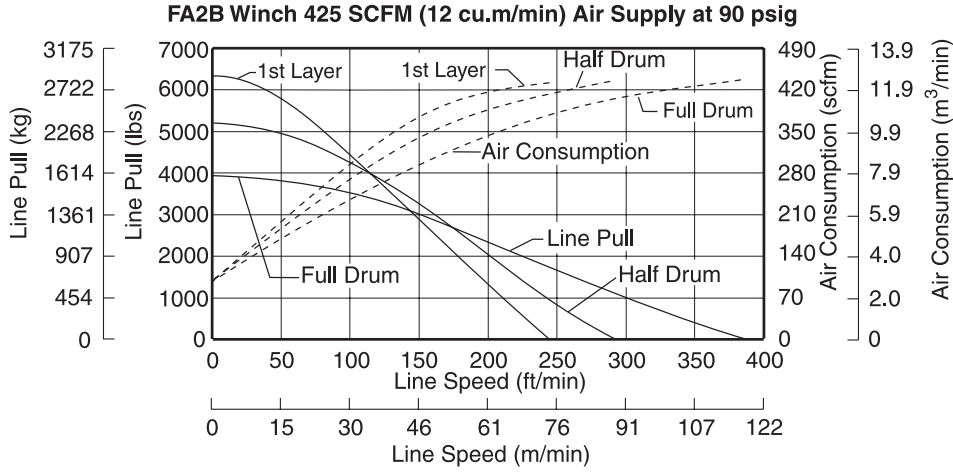

(Dwg. MHP1832)

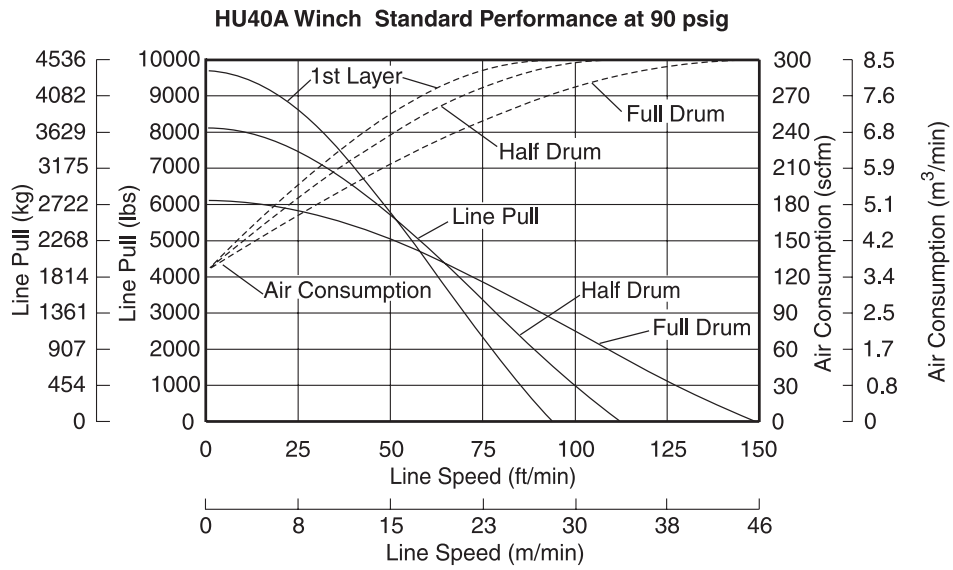

(Dwg. MHP1850)

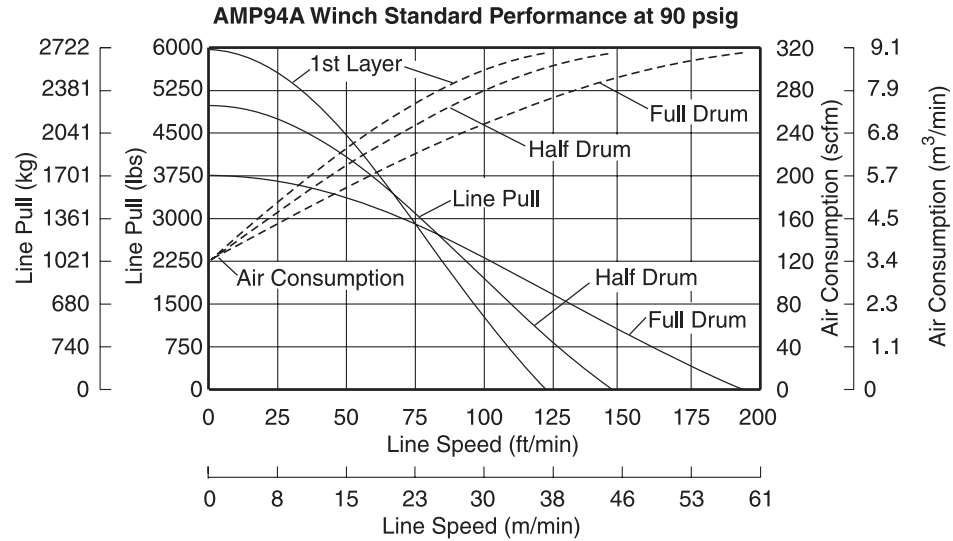

(Dwg. MHP1851)

Wire Rope Storage

Drum Length		Storage Notes	Wire Rope Diameter							
			3/8 inch	10 mm	7/16 inch	11 mm	1/2 inch	13 mm	5/8 inch	16 mm
inches	mm		feet	metres	feet	metres	feet	metres	feet	metres
7	178	Full Drum Storage less 2 wire rope layers	445	130	335	102	245	59	125	38
13-1/2	343		880	258	660	203	495	119	255	77
20	508		1310	386	990	304	740	178	380	115
24	610		1580	464	1195	367	895	214	460	139
7	178	Full Drum Storage less 1/2 inch (13 mm) (per ASME B30.7)	515	151	395	120	300	74	165	50
13-1/2	343		1015	299	780	240	600	148	335	101
20	508		1520	447	1170	360	900	222	500	152
24	610		1830	538	1410	433	1085	268	605	183
7	178	Full Drum Storage	585	173	455	140	355	90	205	63
13-1/2	343		1160	342	910	279	710	180	420	127
20	508		1740	512	1360	418	1065	270	630	191
24	610		2090	616	1640	503	1285	325	760	230

INSTALLATION

Prior to installing the winch, carefully inspect it for possible shipping damage.

Winch gearbox and disc brake, if equipped, are supplied fully lubricated from the factory. Check oil levels and adjust as necessary before operating winch. Refer to "LUBRICATION" section for recommended oils.

⚠ CAUTION

• Owners and users are advised to examine specific, local or other regulations, including American National Standards Institute and/or OSHA Regulations which may apply to a particular type of use of this product before installing or putting winch to use.

Mounting

Refer to Dwg. MHP0124 on page 10 and Table 1 on page 10. Care must be taken when moving, positioning or mounting the winch. The winch has lifting eyebolts mounted to both uprights to assist in moving the unit. Attach hooks or a suitable sling to these eyebolts when moving the winch. Refer to "SPECIFICATIONS" section on page 7 to determine winch weight.

⚠ WARNING

• Do NOT use motor eyebolt for lifting entire winch. Motor eyebolt is designed to hold only weight of motor.

Mount winch so drum axis is horizontal and motor control valve pad is not more than 15° off top vertical center. If winch is to be mounted in an inverted position, the motor case must be rotated to position control valve pad at the top and adequate clearance must be provided for control valve operation.

Position winch to provide unrestricted access to winch control valve and optional free spool lever, if installed.

Do not mount winch in a vertical position, with motor up or down. Reduction gear box lubrication is not designed for this type of installation.



⚠ WARNING

• Winch frame material is not suitable for welding. Winches must only be mounted by bolting to a suitable foundation. Do not attempt to mount the winch by welding to a foundation structure.

1. The winch mounting surface must be flat and of sufficient strength to handle the rated load plus the weight of the winch and attached equipment. An inadequate foundation may cause distortion or twisting of the winch uprights and side rails resulting in winch damage.
2. Make sure mounting surface is flat to within 1/32 inch (0.8 mm). Shim if necessary.
3. Mounting bolts must be 3/4 inch NC (18 mm) Grade 8 or better. Use self-locking nuts or nuts with lockwashers.
4. Tighten mounting bolts evenly and torque to 380 ft-lbs (515 Nm) for dry thread fasteners. If the fasteners are plated, lubricated or a thread-locking compound is used, torque to 280 ft-lbs (380 Nm).
5. Maintain a fleet angle between the lead sheave and winch of no more than 1-1/2°. The lead sheave must be on a center line with the drum and, for every inch (25 mm) of drum length, be at least 1.6 feet (0.5 metre) from the drum. Refer to Dwg. MHP0498 on page 12.
6. Do not weld to any part of the winch.

Winch Mounting Location Drawing

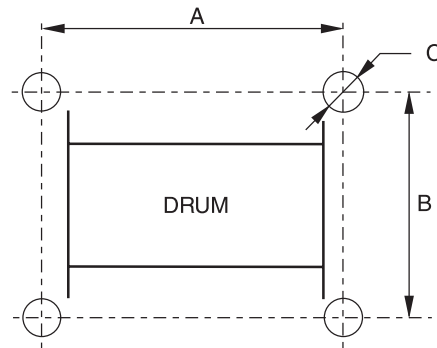

(Dwg. MHP0124)

Table 1: Mounting Bolt Hole Dimensions

Dimension		Drum Length (inches)							
		Without Drum Brake				With Drum Brake			
		7	13.5	20	24	7	13.5	20	24
'A'	in.	9.54	16.04	22.54	26.54	12.3	18.8	25.3	29.3
	mm	242	408	573	674	313	478	643	744
'B'	in.	15							
	mm	381							
'C'	in.	0.81							
	mm	20.6							

Wire Rope

⚠ CAUTION

- **Maintain at least 3 tight wraps of wire rope on drum at all times. Refer to Dwg. MHP0498 on page 12.**

Install winch so that wire rope, when at takeoff angle limits, shown in Dwg. MHP1842 on page 11 or MHP0975 on page 11, does not contact mounting surface.

⚠ DANGER

- **Exceeding wire rope takeoff angles will cause wire rope to come into contact with winch frame supports resulting in damage to wire rope and winch.**

Wire Rope Takeoff Angles - Standard Winch

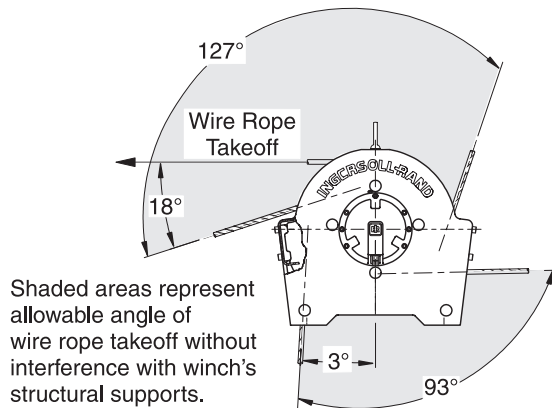

Shaded areas represent allowable angle of wire rope takeoff without interference with winch's structural supports.

Viewed from end opposite motor

(Dwg. MHP1842)

Wire Rope Takeoff Angles - Open Frame (Face) Winch

Shaded areas represent allowable angle of wire rope takeoff without interference with winch's structural supports.

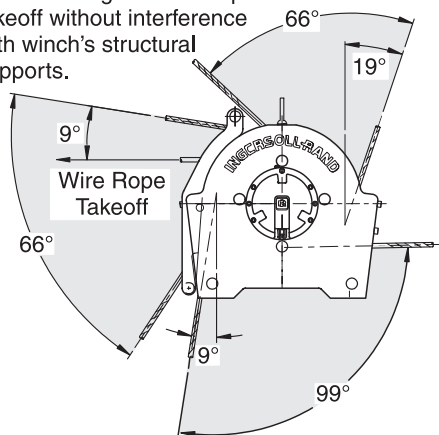

Viewed from end opposite motor

(Dwg. MHP0975)

Wire Rope Selection

Consult a reputable wire rope manufacturer or distributor for assistance in selecting the appropriate type and size of wire rope and, where necessary, a protective coating. Use a wire rope that provides an adequate safety factor to handle the actual working load and that meets all applicable industry, trade association, federal, state and local regulations.

When considering wire rope requirements the actual working load must include not only the static or dead load but also loads resulting from acceleration, retardation and shock load.

Consideration must also be given to the size of the winch wire rope drum, sheaves and method of reeving. Wire rope construction must be EIPS 6 X 19 IWRC with a right lay to assist spooling and installation of wire rope anchor. Wire rope construction providing a non-rotating or anti-spin characteristic is recommended. Refer to Table 2 for recommended wire rope sizes.

Table 2: Wire Rope Size

Wire Rope Anchor Part No.	Minimum		Maximum	
	inch	mm	inch	mm
25539	3/8	10	5/8	16

Note: To maintain 5:1 safety factor ratio 1/2 inch (13 mm) wire rope must be used.

Installing Wire Rope

Refer to Dwg. MHP0652 on page 11.

1. Cut wire rope to length and fuse end to prevent fraying of strands in accordance with wire rope manufacturer's instructions.
2. Feed the end of the wire rope into wire rope anchor hole in drum and pull through approximately three feet (1 metre) of wire rope.
3. Forming a large loop with wire rope, insert end back into top of anchor hole.
4. Place wire rope wedge into wire rope anchor pocket in drum. Install wedge so that wire rope will wrap around wedge as shown in Dwg. MHP0652 on page 11.

Wire Rope Installation Drawing

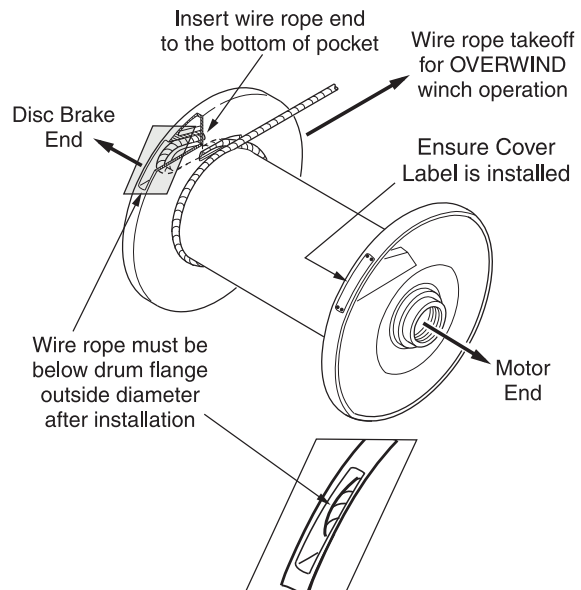

(Dwg. MHP0652)

- Pull wire rope into position in drum anchor pocket. Ensure wire rope is installed below edge of the drum flange diameter. Use of a copper drift or similar tool may be required to fully insert wire rope and wedge into anchor pocket.

⚠ CAUTION

- Make sure the first wrap of wire rope is tight and lies flush against drum flange.
 - Ensure correct wire rope anchor is used.
 - Install wire rope to come off drum in an overwind position.
- Improper installation of wire rope can result in failure of disc brake to hold load. Refer to Dwg. MHP0652 on page 11.**

Safe Wire Rope Handling Procedures

- Always use gloves when handling wire rope.
- Never use wire rope which is frayed or kinked.
- Never use wire rope as a sling.
- Always ensure wire rope is correctly spooled and the first layer is tight against the drum.
- Always follow wire rope manufacturer's recommendations on use and maintenance of wire rope.

Wire Rope and Fleet Angle Installation Drawing

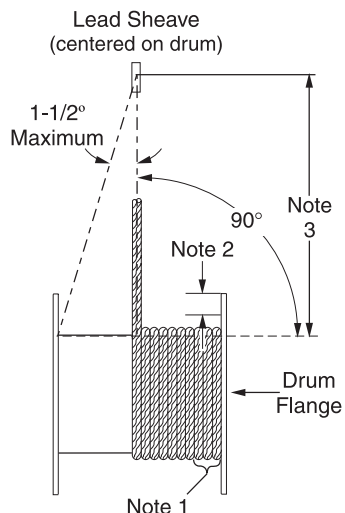

(Dwg. MHP0498)

Notes:

- Maintain a minimum of 3 tight wraps of wire rope on drum at all times.
- Ensure wire rope does not exceed top layer requirement. Refer to "SPECIFICATIONS" section.
- For correct fleet angle maintain a minimum of 1.6 feet (0.5 metre) per inch of drum length. Example: for 7 inch drum length locate lead sheave at least 11.2 feet (3.5 metres) from drum.

Wire Rope Spooling

To compensate for uneven spooling and the decrease in line pull capacity as the drum fills up, use as short a wire rope as practical. When rewinding, apply tension to the end of the wire rope to eliminate line slack. This helps achieve level winding and tight spooling.

Rigging

Make sure all wire rope blocks, tackle and fasteners have a safety margin sufficient to handle the required load under all conditions. Do not allow wire rope to contact sharp edges or make sharp bends which will cause damage to wire rope. Use a sheave. Refer to wire rope manufacturer's handbook for proper sizing, use and care of wire rope.

Safe Installation Procedures

- Do not use wire rope as a ground (earth) for welding.
- Do not attach a welding electrode to winch or wire rope.
- Never run the wire rope over a sharp edge. Use a correctly sized sheave.
- When a lead sheave is used, it must be aligned with the center of the drum. The diameter of the lead sheave must be at least 18 times the diameter of the wire rope. Refer to Dwg. MHP0498 on page 12.
- Always maintain at least three full, tight wraps of wire rope on the drum.

Air Supply

The air supply should be clean and filtered to ensure optimum motor performance and minimize wear. Foreign particles are the primary causes of premature motor wear and breakdown. Using an air filter will improve overall winch performance and reduce unscheduled downtime.

FA2B Winch Motor

Maximum air consumption is 425 scfm (12 cu. m/min) at rated operating pressure of 90 psig (6.3 bar/630 kPa) at the winch motor inlet.

HU40A Winch Motor

Maximum air consumption is 300 scfm (8.5 cu. m/min) at rated operating pressure of 90 psig (6.3 bar/630 kPa) at the winch motor inlet.

AMP94 Winch Motor

Maximum air consumption is 320 scfm (9.1 cu. m/min) at rated operating pressure of 90 psig (6.3 bar/630 kPa) at the winch motor inlet.

If air supply varies from recommended, winch performance will change. Refer to 'Performance Graphs' on page 8.

Air Lines

The inside diameter of winch air supply lines must be at least 1-1/4 inch (32 mm) to achieve maximum performance. Use of smaller diameter lines will result in reduced performance (lower speeds). Before making final connections, all air supply lines should be purged with clean, moisture-free air or nitrogen before connecting to winch inlet. Supply lines should be as short and straight as installation conditions will permit. Long transmission lines and excessive use of fittings, elbows, tees, globe valves etc. cause a reduction in pressure due to restrictions and surface friction in the lines.

Air Line Lubricator

Refer to Dwg. MHP0191 on page 13.

An air line lubricator is not required with the FA2B air motor when the supplying air source is either a portable compressor or air compressor system without an air dryer or coalescing filter located between the compressor and winch motor. However, using an air line lubricator will extend piston ring life.

An air line lubricator is required for the HU40A and AMP94A air motors.

The lubricator must have an inlet and outlet at least as large as the inlet on the motor directional control valve. Install air line lubricator as close to air inlet on motor as possible.

Lubricator Settings

Motor	Minimum Required	Minimum Recommended	Overhauling Operation
	(drops per minute)		
FA2B	0	3-6	6-8
HU40A	3-6		
AMP94A	3-6		

Do not exceed values stated.

CAUTION

- Shut off air supply before filling air line lubricator, if equipped.
- If used for Overhauling Operation, the motor must have inline lubrication. Install an airline lubricator and set at 6 to 8 drops per minute. Refer to 'Overhauling' in the "OPERATION" section.

If equipped, the air line lubricator should be replenished daily and set to provide 3 drops per minute of ISO VG 32 (10W SAE) oil. For optimum performance and maximum durability of parts, provide a lubricated air supply. The air motor should be installed as near as possible to the compressor or air receiver. Recommended pressures and volumes are measured at the point of entry to the air motor directional control valve.

Air Line Filter

Refer to Dwg. MHP0191 on page 13.

Place strainer/filter as close as practical to motor air inlet port, but upstream from lubricator, to prevent dirt from entering motor. The filter/strainer should provide 50 micron filtration and include a moisture trap. Clean the filter/strainer periodically, as experience dictates, to maintain its operating efficiency. Refer to manufacturer's literature for cleaning/replacing recommendations.

Air Pressure Regulator

Refer to Dwg. MHP0191 on page 13.

If an air pressure regulator is used, install between lubricator and filter as shown in Dwg. MHP0191 on page 13.

Moisture in Air Lines

FA2B Air Motor

Moisture that reaches the air motor through air supply lines provides lubrication to the piston rings. Over prolonged periods of operation, depending upon moisture content in the air, water will build up in bottom of motor housing. This accumulation must be drained to maximize bearing life. Refer to 'Draining Motor Housing' on page 14 in the "OPERATION" section.

HU40A and AMP94A Air Motors

Over prolonged periods of operation, depending upon moisture content in the air, water will buildup in motor housing sump. This accumulation must be drained to maximize life of motor components. Refer to 'Draining Motor Housing' on page 14 in the "OPERATION" section.

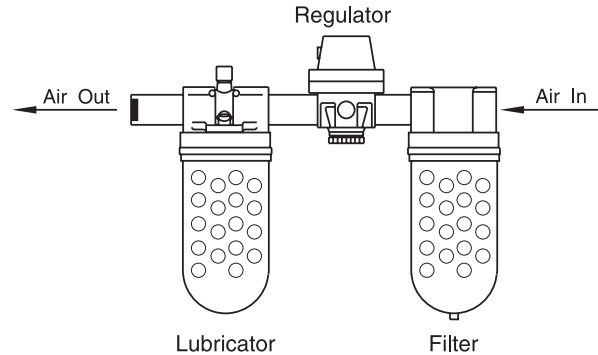

(Dwg. MHP0191)

Mufflers

Ensure muffler is installed in exhaust port of control valve. On FA2B Winch Air Motors, ensure muffler is installed in at least one exhaust port on rotary housing. The motor rotary housing has two exhaust ports. Installation of two mufflers in rotary housing is optional. Check mufflers periodically to ensure they are functioning correctly.

Natural Gas Operation (optional feature)

WARNING

- Ensure all fittings and connections are tight. Inspect all connections with suitable leak detection equipment.
- At first notice of any unusual odors or noticeable leaks, cease winch operation until source is identified and corrected.
- Natural gas exhaust must be piped away from the winch.

The FA2B winch may be run using natural gas. However, motor and valve modifications are required for this usage. Refer to parts section for additional information.

Use of natural gas will reduce motor life.

Natural gas exhausting from the winch must be piped away.

Natural Gas Warning Label



Initial Winch Operating Checks

Winches are tested for proper operation prior to leaving factory. Before winch is placed into service the following initial operating checks should be performed.

1. When first running motor, inject light oil into inlet connection to provide initial lubrication.
2. When first operating the winch, it is recommended that motor be driven slowly in both directions for a few minutes.

For winches that have been in storage the following start-up procedures are required.

1. Give winch an inspection conforming to the requirements of 'Winches Not in Regular Use' in "INSPECTION" section.
2. Pour a small amount of ISO VG 32 (10W SAE) oil in motor inlet port.
3. Operate motor for 10 seconds in both directions to flush out any impurities.
4. Check to ensure oil levels are "full".
5. The winch is now ready for normal use.

OPERATION

It is recommended that the user and owner check all appropriate and applicable regulations before placing this product into use.

The four most important aspects of winch operation are:

1. Follow all safety instructions when operating the winch.
2. Allow only people trained in safety and operation of this winch to operate this equipment.
3. Subject each winch to a regular inspection and maintenance procedure.
4. Be aware of winch capacity and weight of load at all times.

CAUTION

- To avoid damage to rigging, structure supporting rigging and winch, do not "two-block"* end of wire rope.

* Two blocking occurs when winch wire rope is multi-reeved using two separate sheave blocks which are allowed to come into contact with each other during winch operation. When this occurs extreme forces are exerted on wire rope and sheave blocks which may result in equipment and or rigging failure.

WARNING

- Never lift loads over people.

Operators must be physically competent. Operators must not have a health condition which might affect their ability to act, and they must have good hearing, vision and depth perception. The winch operator must be carefully instructed in his duties and must understand the operation of the winch, including a study of the manufacturer's literature. The operator must thoroughly understand proper methods of hitching loads and must have a good attitude regarding safety. It is the operator's responsibility to refuse to operate the winch under unsafe conditions.

Air Motor

Draining Motor Housing

During normal operation moisture can collect in the motor housing. This accumulation should be drained regularly. Excess moisture in the housing will decrease bearing life. In addition, freezing moisture can lead to damaged motor components.

FA2B Winch Motor

Refer to Dwg. MHP1796 on page 44. To drain, locate and remove plug (71) in bottom of motor housing (72). Any fluid drained should be disposed of in an environmentally safe manner.

HU40A Winch Motor

Refer to Dwg. MHP1827 on page 46. Allow motor to stand idle long enough for oil and water to separate. Remove level plug (712) and drain excess fluid. This fluid may be contaminated with oil and should be disposed of in an environmentally safe manner.

AMP94A Winch Motor

Refer to Dwg. MHP1845 on page 48. Allow motor to stand idle long enough for oil and water to separate. Remove level plug (216) and drain excess fluid. This fluid may be contaminated with oil and should be disposed of in an environmentally safe manner.

Overhauling Operation

Overhauling operation is similar to using the air motor as an air spring. The load overpowers the motor, causing it to turn backwards against the inlet air supply.

This type of operation is not uncommon for winch operation and air motors are designed to withstand this type of usage for limited periods.

⚠ CAUTION

• If the FA2B motor is used for overhauling operations inline lubrication is required. Set inline lubricator to provide a minimum of 6-8 drops per minute. Refer to “LUBRICATION” section for recommended lubricants.

Overhaul Operation Duty Cycle

Motor Speed (rpm)	Maximum Continuous Duty Cycle (minutes)	Minimum Idle Time Between Duty Cycles (minutes)
600	5 minutes	20*
1200	3 minutes	

* Minimum idle time may be replaced by 10 minutes powered forward operation.

HU40A and AMP94A air motors, with their oil sump design and required lubricated air supply, have no additional lubrication requirements.

Winch Controls

A spring loaded, motor-mounted, manual throttle control valve is supplied as a standard feature on these winches. Optional remote pendant controls are also available. Reference the model code on winch nameplate and compare it to “SPECIFICATIONS” section of this manual to determine winch configuration. The throttle control provides operator control of motor speed and direction of drum rotation.

Operate winch throttle control using smooth, even movements. Do not slam or jerk throttle controls during operation.

Winch Mounted Air Throttle

FA2B

Refer to Dwg. MHP1809 on page 15.

The spring loaded, live air, manual control throttle valve mounts to the rotary housing.

To operate control valve, place palm of hand on control knob and wrap fingers around flange of sliding handle. Squeeze fingers, lifting sliding handle up to unlock control lever. Shift control lever in desired direction to payout or haul-in wire rope.

As viewed from the air motor end, move the control throttle handle to the right (clockwise) to payout wire rope and to the left (counterclockwise) to haul-in wire rope. Avoid sudden movements of the control valve to ensure smooth operation of the winch.

When released, handle will return to the neutral or center position. The sliding handle will drop down to engage and lock the control handle in place.

FA2B Winch Mounted Throttle Control Valve Operation

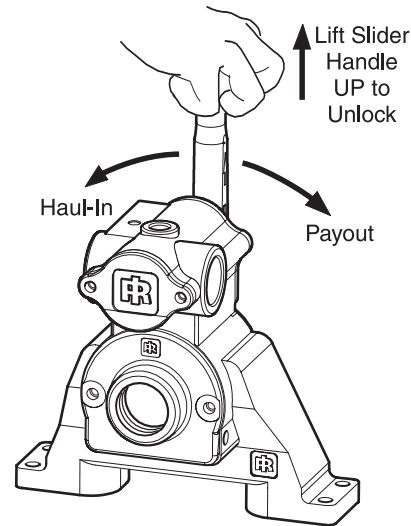

(Dwg. MHP1809)

HU40A

Refer to Dwg. MHP1839 on page 15.

The spring loaded, live air, manual control throttle valve mounts to the air motor. To operate control valve, grasp control lever knob and move towards air motor. This will unlock control lever. Shift control lever in desired direction to payout or haul-in wire rope.

As viewed from the air motor end, move the control throttle handle to the right (clockwise) to payout wire rope and to the left (counterclockwise) to haul-in wire rope. Avoid sudden movements of the control valve to ensure smooth winch operation.

When released, handle will return to the neutral or center position. The handle will engage and lock the control handle in place.

HU40A Winch Mounted Throttle Control Valve Operation

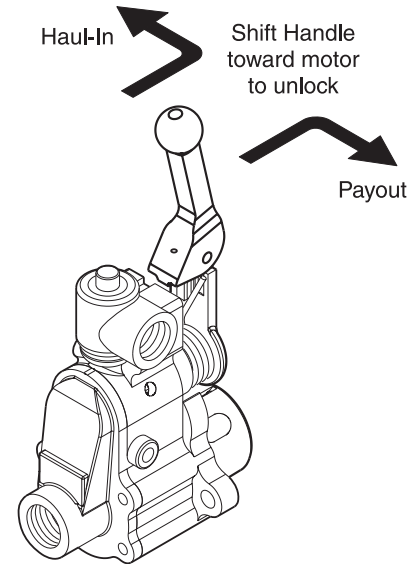

(Dwg. MHP1839)

AMP94A

Refer to Dwg. MHP1848 on page 16.

The spring loaded, live air, manual control throttle valve mounts to the valve adapter. To operate control valve, lift the control handle to vertical. The control handle has a spring detent to keep it in the neutral position. Shift control lever in desired direction to payout or haul-in wire rope.

As viewed from the air motor end, move the control throttle handle to the right (clockwise) to payout wire rope and to the left (counterclockwise) to haul-in wire rope. Avoid sudden movements of the control valve to ensure smooth operation of the winch. When winch is not in use, pivot the handle to the horizontal position. This will prevent inadvertent movement of control handle.

AMP94A Winch Mounted Throttle Control Valve Operation

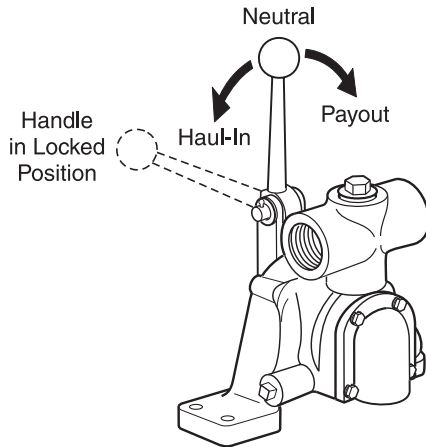

(Dwg. MHP1848)

Remote Full Flow Throttle (optional feature)

Refer to Dwg. MHP1841 on page 59.

Provides for the remote mounting of winch control at a fixed location up to 20 feet (6 metres) away from winch motor. Air hoses connect throttle to winch motor to provide remote operation.

Move control lever to the right (clockwise), as viewed from the exhaust side of throttle valve, to payout wire rope. Move control lever to the left (counterclockwise), as viewed from the exhaust side of throttle valve, to haul-in wire rope. To ensure smooth winch operation, avoid sudden movements of control lever.

Remote Pilot Lever Throttle (optional feature)

Refer to Dwg. MHP1846 on page 56.

Provides for remote winch control at a fixed location up to 50* feet (15 metres) away from winch. Air hoses connect throttle to winch motor to provide remote operation.

Pilot pressure from lever pilot control throttle activates winch control valve located on winch motor. Winch control valve controls motor speed and direction of drum rotation. Drum rotation direction is determined by direction pilot control throttle lever is shifted.

* For distances greater than 50 feet (15 metres) contact **Ingersoll-Rand** Technical Sales for control suitability.

Remote Pilot Pendant Throttle (optional feature)

Refer to Dwg. MHP1311 on page 16 and MHP1846 on page 56. Provides for remote winch control at distances up to 50* feet (15 metres) away from the winch motor. Pilot air hoses connect the pendant to the winch motor pilot air valve to provide winch operation. The pendant control is a two lever movable control station which controls payout and haul-in.

Direction of winch drum rotation is determined by the pendant lever depressed. Air is directed from the pendant into the pilot valve. The pilot valve spool shifts to direct control air into the winch motor to operate the winch in the desired direction. Winch operation must correspond to the directions indicated by the arrows located on the pendant levers.

Depress pendant levers using smooth, even movements. To operate the winch using the pendant:

1. To operate in the haul-in direction, depress the 'RIGHT' lever.
2. To operate in the payout direction, depress the 'LEFT' lever.
3. To throttle operating speed regulate the amount the lever is depressed. Depress lever completely for maximum speed; depress lever partially for slower speeds.
4. To stop haul-in or payout operation release the lever. Lever will spring return to off and winch motor will stop.

NOTICE

• **Pendant haul-in and payout levers provide variable speed operation. For low speed operation push appropriate lever slightly; for full speed operation push appropriate lever fully.**

* To ensure accurate winch control when remotely operating the winch at distances greater than 50 feet (15 metres) contact **Ingersoll-Rand** Technical Sales for control suitability.

Pendant Operation

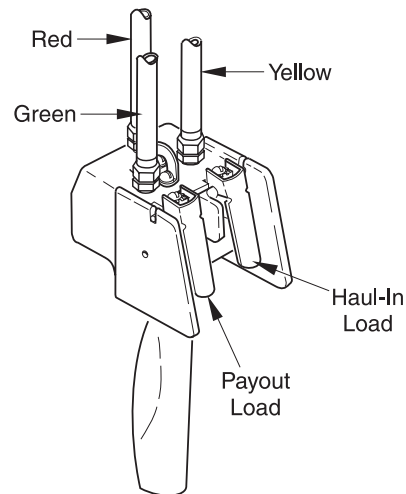

(Dwg. MHP1311)

Winch Brakes

Automatic Disc Brake

The automatic disc brake is spring applied, air released. When the winch is operated in payout direction, air pressure acting on the diaphragm overcomes spring pressure and releases brake. The brake automatically engages when winch operation is returned from payout direction to neutral or when shifted to haul-in direction. When winch is in neutral or haul-in positions the brake air is vented and brake springs apply the brake. The springs, acting on the pressure plate, compress brake friction and separator plates and engage brake to prevent drum rotation in payout direction. The cam type sprag clutch assembly allows drum rotation in haul-in direction with brake plates engaged, but prevents drum from rotating in payout direction.

A minimum air pressure of 25 psi (1.72 bar/172.4 kPa) is required to release brake.

Disc brake adjustment is not required. If disc brake does not operate properly it must be disassembled, inspected and repaired.

Manual Drum Brake (optional feature)

Refer to Dwg. MHP1375 on page 17.

The manual drum brake may be applied by pushing down on the handle and released by pulling up. By pushing the handle down fully, it will go over-center and lock in that position, preventing drum rotation. The drum brake must be kept properly adjusted to hold the required load. Refer to 'Adjustments' in the "MAINTENANCE" section. If brake band cannot be adjusted to hold the rated load, the brake must be disassembled, inspected and repaired.

Drum Brake Handle Operation

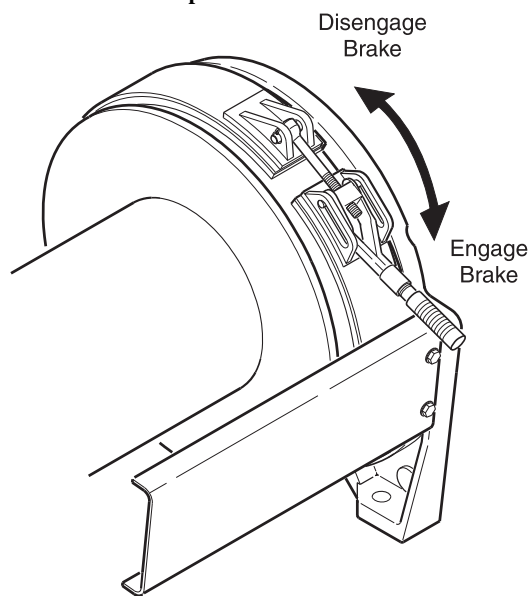

(Dwg. MHP1375)

Automatic Drum Brake (optional feature)

The automatic drum brake is a spring applied, air released, externally mounted brake which uses an air actuated, spring loaded cylinder to automatically disengage the brake when the motor is operated in either the haul-in or payout directions. Air pressure directed to the cylinder overcomes spring pressure to release brake and allow drum to rotate.

When the control valve is placed in the neutral position, air in the cylinder is vented which allows the cylinder spring to automatically engage brake and prevent drum rotation.

Adjustments to the cylinder clevis can be made to compensate for normal brake lining wear. The drum brake must be kept properly adjusted to hold the required load. Refer to 'Adjustments' in the "MAINTENANCE" section. If brake band cannot be adjusted to hold rated load, the brake must be disassembled, inspected and repaired.

Free Spool (optional feature)

Refer to Dwg. MHP1322 on page 18 and MHP1828 on page 66. The Free Spool option allows wire rope to be spooled from the drum without operating winch motor.

During normal winch operations the free spool is in non-free spool position. The output shaft connects outboard upright to drum. The free spool handle is in the DOWN position.

⚠ WARNING

• To avoid damage to mounting structure and winch, the winch drum must be stationary and there must be no load on wire rope during Free Spool operation.

Free Spool Position:

1. Engage drum band brake to lock drum in position.
2. Pull handle (512) out.
3. Rotate handle (512) counterclockwise, 180° to the 'UP' position.
4. Release handle. Ensure handle is engaged in slots in detent plate (514).

The drum is now in free spool. During free spool operations use drum band brake to control drum speed during wire rope payout.

Non Free Spool Position:

Before operating winch with motor, ensure winch is not in free spool mode.

1. Engage drum band brake.
2. Pull handle (512) out.
3. Rotate handle clockwise, 180° to the 'DOWN' position. This connects winch drum to outboard upright. If required, band brake can be released and drum slowly rotated by hand to assist in lining up output shaft (32) splines with upright.
4. Release handle. Ensure handle is engaged in slot in detent plate (514).

Free Spool Operation

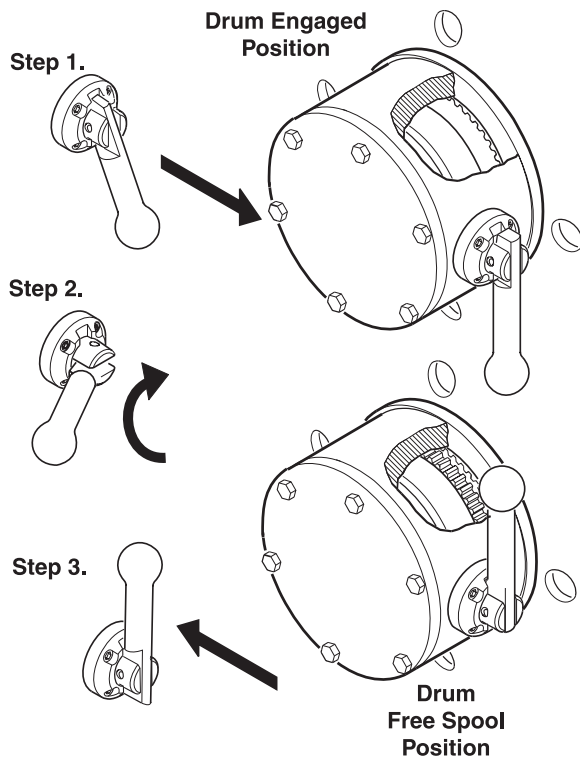

Reverse procedure before operating winch.

(Dwg. MHP1322)

INSPECTION

Inspection information is based in part on American National Standards Institute Safety Codes (ASME B30.7).

⚠ WARNING

- All new or repaired equipment should be inspected and tested by personnel instructed in safety, operation and maintenance of this equipment to ensure safe operation at rated specifications before placing equipment in service.
- Never use a winch that inspection indicates is damaged.

Frequent and periodic inspections should be performed on equipment in regular service. Frequent inspections are visual examinations performed by operators or personnel trained in safety and operation of this equipment and include observations made during routine equipment operation. Periodic inspections are thorough inspections conducted by personnel trained in the safety, operation and maintenance of this equipment. ASME B30.7 states inspection intervals depend upon the nature of the critical components of the equipment and the severity of usage. The inspection intervals recommended in this manual are based on intermittent operation of the winch eight hours each day, five days per week, in an environment relatively free of dust, moisture, and corrosive fumes. If the winch is operated almost continuously or more than eight hours each day, more frequent inspections will be required.

Careful inspection on a regular basis will reveal potentially dangerous conditions while still in the early stages, allowing corrective action to be taken before condition becomes dangerous. Deficiencies revealed through inspection, or noted during operation, must be reported to designated personnel instructed in safety, operation and maintenance of this equipment. A determination as to whether a condition constitutes a safety hazard must be decided, and the correction of noted safety hazards accomplished and documented by written report before placing the equipment in service.

Records and Reports

Inspection records, listing all points requiring periodic inspection should be maintained for all load bearing equipment. Written reports, based on severity of service, should be made on the condition of critical parts as a method of documenting **periodic** inspections. These reports should be dated, signed by the person who performed the inspection, and kept on file where they are readily available for authorized review.

Wire Rope Report

Records should be maintained as part of a long-range wire rope inspection program. Records should include the condition of wire rope removed from service. Accurate records will establish a relationship between visual observations noted during frequent inspections and actual condition of wire rope as determined by periodic inspections.

Frequent Inspection

On equipment in continuous service, frequent inspection should be made by operators at the beginning of each shift. In addition, visual inspections should be conducted during regular operation for indications of damage or evidence of malfunction (such as abnormal noises).

1. NATURAL GAS OPERATION (optional feature). Check all connections and fittings with a suitable leak detector. Repair all leaks.

NOTICE

• **Operating motor with natural gas will reduce the life of motor. Frequency of inspections should be increased. Refer to the Inspection Intervals on page 19.**

• **Natural gas may contain high levels of sulphur, which will result in sulfuric acid ('Sour Gas') in the air system. This acid is very corrosive and will cause motor seals, 'O' rings, rotating shafts and bearings to deteriorate at a greater rate than those exposed to compressed air.**

2. WINCH. Prior to operation, visually inspect winch housings, controls, brakes, sideframes, uprights and drum for indications of damage. Any discrepancies noted must be reviewed and inspected further by authorized personnel instructed in the operation, safety and maintenance of this winch.
3. WIRE ROPE. Visually inspect all wire rope which can be expected to be in use during the day's operations. Inspect for wear and damage indicated by distortion of wire rope such as kinking, "birdcaging," core protrusion, main strand displacement, corrosion, broken or cut strands. If damage is evident, do not operate winch until the discrepancies have been reviewed and inspected further by personnel knowledgeable on wire rope safety and maintenance procedures.

NOTICE

• **The full extent of wire rope wear cannot be determined by visual inspection. At any indication of wear inspect wire rope in accordance with instructions in 'Periodic Inspection.'**

4. AIR SYSTEM. Visually inspect all connections, fittings, hoses and components for indication of air leaks. Repair any leaks or damage.
5. BRAKES. During winch operation test brakes. Brakes must hold load without slipping. Automatic brakes must release when winch motor throttle or pendant is operated. If brakes do not hold load, or do not release properly, the brakes must be adjusted or repaired.
6. WIRE ROPE REEVING. Check reeving and ensure wire rope is properly secured to the drum. Do not operate winch unless wire rope feeds on and off drum smoothly.
7. LUBRICATION. Refer to the "LUBRICATION" section for recommended procedures and lubricants.
8. MANUAL THROTTLE LEVER. Ensure operation of manual throttle lever is smooth and winch is responsive to lever movement. Lever must return to neutral when released. Refer to 'Winch Controls' in "OPERATION" section for information on neutral and lock positions for specific control valves. If winch responds slowly or control sticks, do not operate winch until all problems have been corrected.

9. FA2B WINCH MOTOR. During operation check motor housing for excess heat build up. Housing should not be hot to the touch. Listen for grinding or knocking noises in motor. There should be no grinding or knocking noises. If equipped with a lubricator, check lubricated air supply provides a minimum of 3 drops per minute (6-8 for Overhauling Operation) of ISO VG 32 (10W SAE) oil. Operate motor slowly in both directions to verify operation.
10. HU40A AND AMP94A WINCH AIR MOTORS. During operation check motor housing for excess heat build up. Housing should not be hot to the touch. There should be no grinding or knocking noises. Check oil level and adjust as necessary. Check lubricated air supply provides a minimum of 3 drops per minute of ISO VG 32 (10W SAE) oil. Operate motor slowly in both directions to verify operation.

Periodic Inspection

Winch periodic inspection intervals vary depending on the conditions listed below:

Lubricated Air - All Air Motors

NORMAL	HEAVY	SEVERE
yearly	semiannually	quarterly

FA2B Winch Air Motor Only

Dry Air (Lube-free)		
NORMAL	HEAVY	SEVERE
quarterly	monthly	weekly
Natural Gas - Normal		
NORMAL	HEAVY	SEVERE
semiannually	quarterly	monthly
Natural Gas - 'Sour Gas'		
NORMAL	HEAVY	SEVERE
quarterly	monthly	weekly

Disassembly may be required as a result of frequent inspection findings or in order to properly inspect individual components. Disassembly steps are described in "MAINTENANCE" section. Maintain written records of periodic inspections to provide an accumulative basis for continuing evaluation. Inspect all items listed in 'Frequent Inspection.' Also inspect the following:

1. FRAMES and UPRIGHTS. Check for deformed, cracked or corroded main components. Replace damaged parts.
2. FASTENERS. Check retainer rings, split pins, capscrews, nuts and other fasteners on winch, including mounting bolts. Replace if missing or damaged and tighten if loose.
3. DRUM and SHEAVES. Check for cracks, wear or damage. Replace if necessary.
4. WIRE ROPE. In addition to "Frequent Inspection" requirements, also inspect for the following:
 - a. Buildup of dirt and corrosion. Clean with steam or a stiff wire brush to remove dirt and corrosion if necessary.
 - b. Loose or damaged end connection. Replace if loose or damaged.
 - c. Check wire rope anchor is secure in drum.

- d. Verify wire rope diameter. Measure diameter of wire rope from crown-to-crown throughout the life of wire rope. Recording of actual diameter should only be done with wire rope under equivalent loading and in the same operating section as accomplished during previous inspections. If actual diameter of wire rope has decreased more than 1/64 inch (0.4 mm) a thorough examination of wire rope should be conducted by an experienced inspector to determine the suitability of wire rope to remain in service. Refer to Dwg. MHP0056 on page 20.

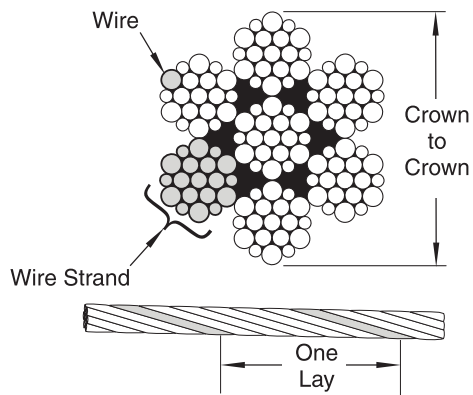

(Dwg. MHP0056)

5. ALL COMPONENTS. Inspect for wear, damage, distortion, deformation and cleanliness. If external evidence indicates damage, disassemble as required to conduct a detailed inspection. Inspect gears, shafts, bearings, sheaves, springs and covers. Replace worn or damaged parts. Clean, lubricate and reassemble.
6. BRAKES. Individually test brakes installed to ensure proper operation. Brakes must hold a 100% rated load at mid-drum without slipping. If indicated by poor operation or visible damage, disassemble and repair brake(s). Check all brake surfaces for wear, deformation or foreign deposits. Clean and replace components as necessary. Adjustments can be made to the drum band brake to compensate for normal brake lining wear. Refer to 'Adjustments' in "MAINTENANCE" section. If brake band cannot be adjusted to hold rated load, replace brake band assembly. Adjustments cannot be made to disc brake. The disc brake must be repaired as described in "MAINTENANCE" section.

7. FOUNDATION or SUPPORTING STRUCTURE. Check for distortion, wear and continued ability to support winch and rated load. Ensure winch is firmly mounted and that fasteners are in good condition and tight.
8. LABELS AND TAGS. Check for presence and legibility of labels. Replace if damaged or missing.
9. DRUM GUARD (optional feature). Verify fasteners are tight and in good condition. Ensure guard is in good condition.
10. FA2B WINCH AIR MOTOR. Inspect piston rings for signs of uneven wear. With rings installed on piston, and piston in cylinder liner, measure the end gap. If total gap (sum of both sides) is 0.09 inch (2.3 mm) or more, replace rings. If rib of ring (thickest section) is less than 0.135 inch (3.4 mm), replace rings. Refer to 'Inspection' on page 33 in "MAINTENANCE" section for additional inspections when motor is disassembled.
11. HU40A WINCH AIR MOTOR. Inspect piston rings for signs of uneven wear. With rings installed on piston and piston in cylinder liner measure end gap. If gap is greater than 0.002 inch (0.05 mm) replace rings. Inspect cylinder for scratches or gouges, replace if any are found.
12. AMP94A WINCH AIR MOTOR. Inspect piston rings for signs of uneven wear. With rings installed on piston and piston in cylinder liner measure end gap. If gap is greater than 0.003 inch (0.08 mm) replace rings. Inspect cylinder for scratches or gouges, replace if any are found.

Winches Not in Regular Use

1. Equipment which has been idle for a period of one month or more, but less than six months, shall be given an inspection conforming to the requirements of 'Frequent Inspection' before being placed in service.
2. Equipment which has been idle for a period of over six months shall be given a complete inspection conforming with requirements of 'Periodic Inspection' before being placed in service.
3. Standby equipment shall be inspected at least semiannually in accordance with requirements of 'Frequent Inspection'. In abnormal operating conditions equipment should be inspected at shorter intervals.

INSPECTION AND MAINTENANCE REPORT

Ingersoll-Rand Force 5 Series Modular Winch

Model Number:	Date:
----------------------	--------------

Serial Number:	Inspected By:
-----------------------	----------------------

Reason for Inspection: (Check Applicable Box)		
	1. Scheduled Periodic Inspection: _____ Quarterly _____ Semiannually _____ Yearly	Operating Environment: Normal _____ Heavy _____ Severe _____
	2. Discrepancies noted during Frequent Inspection	
	3. Discrepancies noted during Maintenance	
	4. Other: _____	

Refer to Parts, Operation and Maintenance Manual "INSPECTION" section for general inspection criteria. Also, refer to appropriate National Standards and codes of practice. If in doubt about an existing condition, contact the nearest **Ingersoll-Rand** Distributor or the factory for technical assistance.

COMPONENT	CONDITION		CORRECTIVE ACTION		NOTES
	Pass	Fail	Repair	Replace	
Uprights and Side Frames					
Drum Band Brake (125% Load Test)					
Automatic Disc Brake (125% Load Test)					
Drum Band Brake (Visual Inspection)					
Disc Brake (Visual Inspection)					
Motor					
Controls					
Fasteners					
Reduction Gears					
Labels and Tags			---		
Shafts					
Guards					
Wire Rope Anchor			---		
Other Components (list in NOTES section)					

TESTING	Pass	Fail	NOTES
Operational (No Load)			
Operational (10%)			
Operational (Maximum Test Load *)			

* Maximum test load is 125% of rated line pull at full drum.

This page may be copied and used as an Inspection/Maintenance Record.

TROUBLESHOOTING

This section provides basic troubleshooting information. Determination of specific causes to problems are best identified by thorough inspections performed by personnel instructed in safety, operation and maintenance of this equipment. The chart below provides a brief guide to common winch symptoms, probable causes and remedies.

SYMPTOM	CAUSE	REMEDY
Winch will not operate.	No air supply to winch.	Check air supply line connections and hoses.
	Winch is overloaded.	Reduce load to within rated capacity.
	Shipping plugs may still be in place.	Remove shipping plugs in control valve.
	Drum brake not released.	Disengage manual drum brake or refer to 'Automatic Drum Brake' below.
Load continues to move when winch is stopped.	Brake(s) slipping.	Check brake band adjustment and brake band lining wear. Disassemble and inspect disc brake.
	Winch motor controls sticking.	Check pendant/throttle levers return to normal (neutral) positions when released. Disassemble, inspect and repair the pilot air control valve. Verify spool adjustment.
Winch does not lift load.	Motor may be damaged.	Remove and disassemble motor. Examine all parts and replace any that are worn or damaged.
	Insufficient air supply.	Verify air supply pressure and volume at winch inlet meets the requirements listed in the "SPECIFICATIONS" section. Clean air line filter.
Throttle moves but winch does not operate.	Motor may be damaged.	Disassemble and clean the motor and replace any worn or damaged parts.
	Insufficient air supply.	Ensure air pressure at the winch inlet is at least 90 psig (6.3 bar/630 kPa) at rated volume. Clean air line filter.
	Air leak.	Check hose connections. Check hose lines for wear or damage. Replace worn or damaged hoses.
Winch runs slow.	Improper hose or fitting sizes.	Check fittings, connections and hoses for correct size and length. Replace parts that may cause restricted air flow. Inspect air line filter.
	Motor may be damaged.	Remove and disassemble motor. Inspect all parts and replace all worn or damaged parts.
	Brake(s) may not be releasing.	Refer to brake sections below.
	Ice in exhaust ports and/or air lines.	Check aftercoolers and traps. Add airline antifreeze to air supply.
	Motor piston ring wear.	If running lube-free and/or moisture free, inspect piston rings.
	Excessive water in motor.	Drain water in motor. Refer to 'Draining Motor Housing' in "OPERATION" section.
Air lines freeze.	Water in air supply.	Install or drain air system moisture traps, moisture collecting air receivers and compressor aftercoolers. After corrective action has been taken, disconnect lines at winch inlet and purge with clean, dry air or nitrogen.

FA2B Winch Air Motor:

Motor runs hot or makes excessive noise during operation.	Damaged or broken motor internal parts.	Disassemble and repair motor.
	Moisture in motor housing.	Drain motor housing. Refill to correct level. Refer to "LUBRICATION" section.

HU40A and AMP94A Winch Air Motor:

Motor runs hot or makes excessive noise during operation.	Damaged or broken motor internal parts.	Disassemble and repair motor.
	Water in oil.	Drain motor housing and refill with oil to correct level. Refer to 'Motor Assembly' in "LUBRICATION" section.
	Low oil level.	Check oil level in motor. Add oil as required to obtain proper level.
	Improper lubrication.	Replace oil with type recommended in "LUBRICATION" section

SYMPTOM	CAUSE	REMEDY
---------	-------	--------

Automatic Drum Brake:

Brake will not release.	Damaged or leaking cylinder seals.	If air is noticed escaping from around the cylinder cover when attempting to release the brake disassemble and inspect brake. Replace all seals and repair or replace worn or damaged parts.
	Dirty filter in air supply.	Clean or replace filter.
Brake does not set when applied.	Hole in exhaust valve restricted or exhaust valve damaged.	Remove and inspect exhaust valve. Clean hole or replace damaged exhaust valve.

Automatic Disc Brake:

Brake fails to release.	Low air supply pressure.	Ensure supply air pressure at the brake inlet is at least 25 psig (1.7 bar/172 kPa).
	Leaking diaphragm.	Disassemble brake and replace diaphragm.
	No release pressure at brake port.	Verify proper operation of winch controls.

LUBRICATION

To ensure continued satisfactory winch operation, all points requiring lubrication must be serviced with correct lubricant at proper time interval as indicated for each assembly. The **FA2B** winch air motor is designed without an oil sump. The only lubrication necessary for operation is that provided by a lubricated air supply. The **HU40A** and **AMP94A** winch air motor oil sump must be maintained at the proper level using appropriate lubricant. Refer to 'HU40A Motor' section on page 25 and 'AMP94A Motor' section on page 25. Lubrication intervals recommended in this manual are based on intermittent operation of the winch eight hours each day, five days per week. If the winch is operated almost continuously or more than eight hours each day, more frequent lubrication will be required. Also, lubricant types and change intervals are based on operation in an environment relatively free of dust, moisture, and corrosive fumes. Use only those lubricants recommended. Other lubricants may affect winch performance. Approval for use of other lubricants must be obtained from your **Ingersoll-Rand** distributor. Failure to observe this precaution may result in damage to the winch and/or its associated components.

INTERVAL	LUBRICATION CHECKS
Start of each shift	If installed, check flow and level of air line lubricator (adjust flow to provide a minimum of 3 drops per minute at maximum motor speed).
Monthly	Inspect and clean or replace air line filter. Check reduction gear oil level.
Yearly	Drain and refill winch reduction gear oil. Drain and refill HU40A and AMP94A winch motors.

General Lubrication

1. Drain and replace oil in disc brake and reduction gear after 50 hours of initial winch operation. Thereafter, drain and replace oil according to intervals recommended above.
2. Always inspect removed oil for evidence of internal damage or contamination (metal shavings, dirt, water, etc.). If indications of damage are noted, investigate and correct before returning winch to service.
3. After winch operation, allow oil to settle before topping off.
4. Always collect lubricants in suitable containers and dispose of in an environmentally safe manner.

Reduction Gear and Disc Brake Lubrication

Refer to Dwg. MHP1553 on page 25. The reduction gear and disc brake are filled with oil from the factory. Check oil level before initial winch operation.

Reduction gear and disc brake components are splash lubricated by oil in the housing and have no other means of lubrication. It is therefore important to use high quality, Extreme Pressure (EP) rust and oxidation inhibited gear oils to ensure maximum performance and minimum downtime for repairs. Oil from the reduction gear assembly also provides lubrication for the disc brake.

Reduction Gear and Disc Brake Recommended Lubricant

Temperature	Recommended Viscosity
Below 32° F (0° C)	ISO VG 68 (20W SAE)
32° to 80° F (0° to 27° C)	ISO VG 100 (30W SAE) *
Above 80° F (27° C)	ISO VG 150 (40W SAE)

* Units are shipped from factory with ISO VG 100 (30W SAE) lubricant. Reduction Gear capacity is approximately 2 quarts (1.9 litres). Disc brake capacity is approximately 4 fl oz (118 ml).

Initial Reduction Gear Assembly Oil Change

It is recommended the first oil change be done after approximately 50 hours initial operation. Always inspect removed oil for evidence of internal damage (metal shavings, dirt, water, etc.).

Reduction Gear Fill/Drain Procedures

Refer to Dwg. MHP1553 on page 25 and MHP1565 on page 42.

NOTICE

• **There are 2 plugged holes, located 90° apart, on reduction gear cover (29). To fill or drain reduction gear oil, winch drum must be rotated to align plugs for either fill or drain operations.**

To Fill:

1. Rotate winch drum to align reduction gear plugs to the fill position. Fill plug position is at top center.
2. Remove fill and drain plugs (31) located on reduction gear cover (29).
3. Winch with disc brake: do not remove level plug located on reduction gear cover. Instead, remove level plug located on disc brake housing.

NOTICE

• **Depending on ambient temperature it may take several minutes for oil to flow from disc brake level plug hole. Wait 10 minutes after oil starts to flow from level plug hole before reinstalling plug fittings.**

4. Fill slowly until oil flows from disc brake level plug hole.
5. Reinstall plugs.

! CAUTION

• **Do not overfill. Excess oil will reduce operating efficiency and increase oil temperature.**
 • **The use of unsuitable oil may result in excessive temperature rise, loss of efficiency and possible damage to the gears. Use only high quality rust and oxidation inhibiting lubricant.**

To Drain:

1. Rotate winch drum to align reduction gear plugs to the drain position. Drain plug is located at bottom center.

- Remove reduction gear drain plug and install long pipe nipple threaded at one end to 3/8-18 NPT. Remove drain vent plug. Remove disc brake drain plug.

NOTICE

• **Always drain oil into a suitable container and inspect drained oil for evidence of damage, metal shavings, dirt, water, etc. Dispose of oil in an environmentally safe manner.**

- Collect drained oil and dispose of properly. If replacing oil, refer to disc brake fill procedure. Reinstall the reduction gear and disc brake plugs.

Reduction Gear and Disc Brake Lubrication Locations

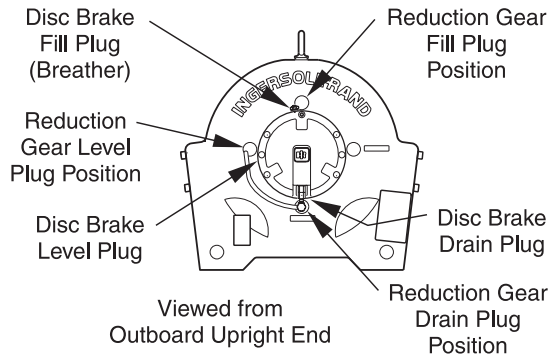

(Dwg. MHP1553)

Disc Brake Fill/Drain Procedures

Refer to Dwg. MHP1553 on page 25 and Dwg. MHP1579 on page 50.

Disc Brake Drain:

- Remove brake air line from elbow fitting (116).
- Remove drain plug (109).
- Collect drained oil and dispose of properly.

Disc Brake Fill:

- Install drain plug (109).
- Remove level plug (109).
- Add oil slowly until oil is level with level plug port.
- Install level plug.
- Install brake air line at fitting (116).

Motor Assembly

An air line lubricator should be installed in air supply line as close as possible to motor inlet, but no more than 10 feet (3 metres) away. Use ISO VG 32 (10W SAE) oil in lubricator. Adjust lubricator to provide recommended quantities listed in Lubricator Settings Table on page 13.

FA2B Winch Motor

⚠ CAUTION

• **FA2B winch motors are designed without an oil sump. Do not fill motor housing with lubricant.**

An air line lubricator is not required with **FA2B** winch motor when supplying air source is either a portable compressor or air compressor system without an air dryer or coalescing filter located between compressor and winch motor. However, though not required for normal operation, the use of an inline filter-lubricator will increase life of the motor.

HU40A Winch Motor

Refer to Dwg. MHP1853 on page 25 and MHP1827 on page 46. The motor is splash lubricated by the oil in motor housing and has no other means of lubrication. It is therefore important to use only good quality, non-detergent motor oil to ensure maximum performance and minimum downtime for repairs. Motor oil capacity is approximately 2 quarts (1.9 litres). Refer to 'HU40A and AMP94A Recommended Lubricants' table on page 25.

HU40A and AMP94A Recommended Lubricants

Temperature	Type Oil
Below 32° F (0° C)	ISO VG 32 (10W SAE)
32° to 80° F (0° to 27° C)	ISO VG 68 (20W SAE)
Above 80° F (27° C)	ISO VG 100 (30W SAE)

* Units are shipped from factory with ISO VG 68 (20W SAE) lubricant.

HU40A Winch Motor Lubrication Locations

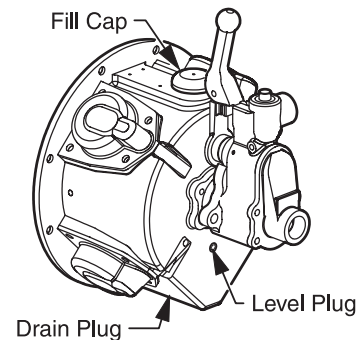

(Dwg. MHP1853)

Add oil through the filler opening until oil flows from the level plug hole.

The motor should be level-checked daily or at the start of each shift after any accumulated water has been drained off. When motors are operated in temperatures below freezing, wait long enough at end of shift for water to separate from oil but not long enough for it to freeze. Drain water then refill to level plug (712), located on the face of motor housing (715). If desired, all the oil may be drained at the end of shift and motor refilled with new oil.

AMP94A Winch Motor

Refer to Dwg. MHP0222 on page 26 and MHP1845 on page 48. The motor is splash lubricated by the oil in the motor housing and has no other means of lubrication. It is therefore important to use only good quality, non-detergent motor oil to ensure maximum performance and minimum downtime for repairs. Refer to 'HU40A and AMP94A Recommended Lubricants' table on page 25.

Motor oil capacity is approximately 3/8 quart (0.35 litres). Add oil through filler opening until oil flows from level plug (216).

AMP94A Winch Motor Lubrication Locations

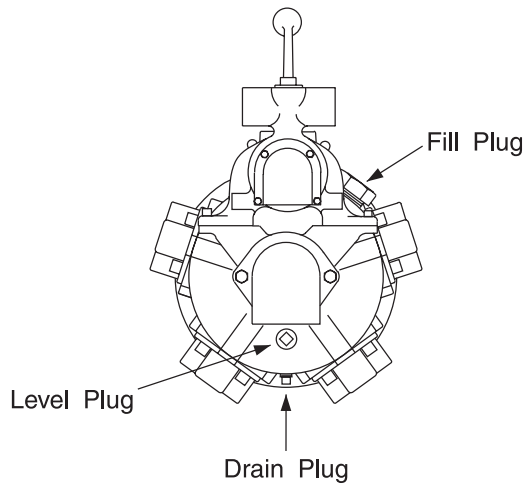

(Dwg. MHP0222)

The motor should be level-checked daily or at the start of each shift after any accumulated water has been drained off. When motors are operated in temperatures below freezing, wait long enough at end of shift for water to separate from oil but not long enough for it to freeze. Drain water then refill to level plug (216), located on the face of motor housing. Refer to Dwg. MHP0222 on page 26. If desired, all the oil may be drained at the end of shift and motor refilled with new oil

Wire Rope

Follow wire rope manufacturer's instructions. At a minimum, observe the following guidelines.

1. Clean with a brush or steam to remove dirt, rock dust or other foreign material on wire rope surface.

⚠ CAUTION

• **Do not use an acid-based solvent. Only use cleaning fluids specified by the wire rope manufacturer.**

2. Apply a wire rope lubricant, **Ingersoll-Rand LUBRI-LINK-GREEN** or ISO VG 100 (30W SAE) lubricant.
3. Brush, drip or spray lubricant weekly, or more frequently, depending on severity of service.

Seals and Bearings

If winch is disassembled, clean all parts thoroughly and coat bearings and seals with clean grease. Refer to 'Recommended Grease' table on page 26. Use sufficient grease to provide a good protective coat.

Recommended Grease

Temperature	Type Grease
-20° to 50° F (-30° to 10° C)	EP 1 multipurpose lithium based grease
30° to 120° F (-1° to 49° C)	EP 2 multipurpose lithium based grease

MAINTENANCE

⚠ WARNING

- Never perform maintenance on the winch while it is supporting a load.
- Before performing maintenance, tag controls:
DANGER - DO NOT OPERATE - EQUIPMENT BEING REPAIRED.
- Only allow personnel trained in safety and service on this winch to perform maintenance.
- After performing any maintenance on the winch, test winch to 125% of its rated line pull at mid drum before returning to service. (Testing to more than 125% of rated line pull may be required to comply with standards and regulations set forth in areas outside the USA.)
- Turn off air system and depressurize air lines before performing any maintenance.

INTERVAL	MAINTENANCE CHECK
Start of each shift (Operator or Maintenance Personnel)	Make a thorough visual inspection of the winch for damage. Do not operate the winch if damaged.
	Operate the winch at low RPM in both directions. Winch must operate smoothly without sticking, binding or abnormal noises. Check the operation of the brake(s).
3 Months (Maintenance Personnel)	Inspect drum brake friction linings. Clean or replace parts as required. Adjust drum brake as necessary.
Yearly (Maintenance Personnel)	Inspect winch gearing, shafts and bearings for wear and damage. Repair or replace as necessary.
	Check all supporting members, including the foundation, fasteners, nuts, sheaves and rigging, etc. for indications of damage or wear. Repair or replace as required.

Thermoplastic Coating

Thermoplastic coating is an extremely tough and durable coating designed to take the toughest treatment without chipping or peeling. Special steps must be taken to protect coating when parts are removed, replaced and if excessive environmental or operational conditions have damaged the coating.

Cleaning Parts

The area to be coated must be clean and free from loose coating. Remove any surface corrosion. To paint thermoplastic coated parts, parts must be sand blasted in order to 'rough up' surface for proper paint adhesion. Sand blasting will not remove thermoplastic coating (abrasive material will bounce off). Loose coating can be removed by cutting with a sharp cutting tool (chisel, putty knife or knife).

Heat Source

⚠ WARNING

- When using an open flame be aware of the materials around work area. Some solvents, lubricants and materials are extremely flammable.
- Drain all components of lubricants, water or any other fluids. Remove, or open all vents and drains. Components will be hot and may discharge hot fluids or gases. Allow sufficient time for components to cool, or cool off components, prior to handling. Gaskets, 'O' rings, and any components that may be damaged should be removed prior to applying coating.

Thermoplastic coating is heat applied. The surface of the component to which thermoplastic coating is being applied must be maintained at a temperature of 150° to 170° F (66° to 77° C). A small propane torch (**Ingersoll-Rand** Part No. 71308886) or heat gun (**Ingersoll-Rand** Part No. 71308894) can be used.

NOTICE

- When using a heat source always keep it moving. Small circles work best. Failure to do so will result in a scorched area at the repair.

The choice of heat gun or propane torch depends on size of area to be coated and amount of time available to accomplish the task. The propane torch heats the surface faster, but is hard to control and can scorch the coating. The heat gun is slower, easier to control and generally results in a better looking finish.

Repairing Surfaces

For minor repairs to the thermoplastic coating conduct the following:

1. If the underlying surface is not corroded and scratch is less than 1/16 inch (1.6 mm) wide, the surrounding thermoplastic coating can be heated until material flows together. For clean surfaces with damage greater than 1/16 inch (1.6 mm) heat the area and then apply thermoplastic coating powder (**Ingersoll-Rand** Part No. 71308902 [2 oz. (56.7 g)]) to fill the area. Continue heating until coating liquidizes and flows together with existing coating.
2. Corrosion in damaged area must be removed. Sandblast or wire brush the area to remove corrosion. If corrosion exists, ensure corrosion has not penetrated below surface of existing thermoplastic coating. This can usually be easily determined by checking to see if coating is loose around corroded area. Cut away coating as necessary to expose corrosion for removal. If damaged area is less than 1/16 inch (1.6 mm) wide the surrounding thermoplastic coating can be heated until material flows together. For surfaces with damage greater than 1/16 inch (1.6 mm) heat area and then apply thermoplastic coating powder (**Ingersoll-Rand** Part No. 71308902) to fill the area. Continue heating until coating liquidizes and flows together with existing coating.
3. Allow repaired area to cool. Quenching with water is acceptable. Inspect the repair. Rough spots, minor scorching and excess coating deposits can be wet sanded to remove imperfections. To return the gloss finish, reheat surface carefully.

For large bare surfaces or new parts:

Coating these components can be done more economically and with better end results by using an electrostatic powder application process or flamespray process. Contact **Ingersoll-Rand** Technical Assistance for more information.

Adjustments

Disc Brake

Brake adjustment is **not** required. If disc brake does not hold 100% of rated load at mid drum, disassemble and repair.

NOTICE

• **Winches are provided with a breather plug located at the top of the disc brake housing. If brake assembly is removed or repaired ensure breather is installed and located at the top of brake housing during reassembly.**

Manual Drum Band Brake

Optional feature. Refer to Dwg. MHP1721 on page 53.

1. Release wire rope tension on the drum.
2. Raise handle (173) to free brake bands (181).
3. Remove cotter pin (178) and pin (177).
4. Rotate brake link stud (179) clockwise to increase brake torque.
5. Install pin (177) and check adjustment.

NOTICE

• **If brake band cannot be adjusted to hold rated load, replace brake band assembly.**

6. Adjust brake so when brake handle locks (goes over-center), brake will hold rated load.
7. Install cotter pin (178) and bend ends apart when adjustment is complete.

For new Brake Linings:

Run-in new brake linings to remove loose material and allow new lining to conform to brake drum.

1. Operate winch while applying increasing pressure to brake band handle until drum stops.

⚠ CAUTION

• **Observe end of load line. Drum should only complete 3-5 full rotations before stopping.**

2. Repeat step 1 twice while operating winch in both directions (payout and haul-in). The brake link stud may require tightening to stop drum rotation.
3. Adjust brake as described in steps 1 through 7 above.

Automatic Drum Band Brake (optional feature)

Refer to Dwg. MHP1730 on page 52.

For adjustments described in the following text, references to “clockwise” and “counterclockwise” directions refer to directions as viewed from the head end of capscrew (149).

NOTICE

• **If brake band cannot be adjusted to hold rated load, replace the brake band assembly.**

1. Loosen jam nut (147) closest to plunger (144).
2. Adjust band assembly using capscrew (149).
 - a. To loosen band brake, turn capscrew (149) in a counterclockwise direction.
 - b. To tighten band brake, turn capscrew (149) in a clockwise direction.

NOTICE

• **If capscrew (149) is not accessible, jam nut (147) [located closest to the head of capscrew (149)] may be used to adjust band brake. Ensure capscrew turns with nut.**

3. When adjustments are complete tighten jam nut (147) closest to plunger (144).

Disassembly

General Disassembly Instructions

The following instructions provide the necessary information to disassemble, inspect, repair, and assemble the winch. **Parts drawings are provided in the Parts Section.**

If a winch is being completely disassembled for any reason, follow the order of the topics as they are presented.

It is recommended that all maintenance work on the winch be performed in a clean, dust-free work area.

In the process of disassembling the winch, observe the following:

1. Never disassemble winch any further than is necessary to accomplish needed repair. A good part can be damaged during the course of disassembly.
2. Never use excessive force when removing parts. Tapping gently around the perimeter of a cover or housing with a soft hammer, for example, is sufficient to break the seal.
3. Do not heat a part with a flame to free it for removal, unless part being heated is already worn or damaged beyond repair and no additional damage will occur to other parts.

In general, the winch is designed to permit easy disassembly and assembly. The use of heat or excessive force should not be required.

4. Keep work area as clean as practical, to prevent dirt and other foreign matter from getting into bearings or other moving parts.
5. All seals, gaskets and ‘O’ rings should be discarded once they have been removed. New seals, gaskets and ‘O’ rings should be used when assembling the winch.
6. When grasping a part in a vise, always use leather-covered or copper-covered vise jaws to protect surface of part and help prevent distortion. This is particularly true of threaded members, machined surfaces and housings.
7. Do not remove any part which is a press fit in or on a subassembly unless removal of that part is necessary for repairs or replacement.

8. When removing ball bearings from shafts, it is best to use a bearing puller. When removing bearings from housings, drive out bearing with a sleeve slightly smaller than the outside bearing diameter. The end of the sleeve or pipe which contacts the bearing must be square. Protect bearings from dirt by keeping them wrapped in clean cloths.

Thermoplastic Coated Parts Disassembly

Thermoplastic coating on capscrew heads, nuts, housings and other components can be removed as follows:

CAUTION

• **Separate parts using proper tools. Ensure machined surfaces are not damaged during disassembly.**

1. Fasteners:
 - a. Push tool into or over fastener, forcing coating off fastener.
 - b. If coating is too thick, heat fastener to soften coating. Socket or wrench will push softened coating off, allowing removal of part.
 - c. For socket-head capscrews, setscrews, etc., heat component until coating is softened. Use a small screwdriver or similar tool to remove coating to allow wrench access.
2. For housings, plates and other coated mating components use a sharp knife or similar tool to cut through coating around mating area of components.

Drum Guard Disassembly (optional feature)

Refer to Dwg. MHP1110 on page 65.

1. Remove eyebolt (41) and washer (42). Remove capscrews (532).
2. Remove brackets (531) or (535) by sliding out of drum guard (537).
3. Carefully remove drum guard (537) from rear (drum brake side) sideframe (12). The drum guard attaches to sideframe using tabs. The smaller, upper tabs are visible on top of the sideframe. The longer, lower tab is located beneath sideframe edge. During removal care must be taken not to bend tabs. To correctly remove, at the point where drum guard and sideframe meet, push or tap lower portion of drum guard in towards winch drum (4). The direction of force should be directly away from sideframe. Do not pull up or down as tabs may become deformed.

Winch Disassembly

Refer to Dwgs. MHP1374 on page 64, MHP1565 on page 42, MHP1579 on page 50 and MHP1796 on page 44.

1. Remove wire rope from drum. Remove wire rope anchor (13) and store for reassembly.
2. Relieve pressure in air lines and winch air components by operating winch control several times after air supply has been turned off.

WARNING

• **Shut off, bleed down and disconnect air supply line before performing any disassembly procedures.**

3. Disconnect and tag air lines.
4. To drain oil refer to “LUBRICATION” section.
5. Remove fasteners securing winch to its foundation and move winch to a suitable work area before beginning disassembly. On FA2B winches use lifting eyebolts installed in winch uprights. Do NOT use eyebolt in motor housing to lift entire winch.

WARNING

• **The air motor may weigh as much as 145 lbs (66 kg). Adequately support air motor before removing motor mounting capscrews.**

6. On FA2B winch, remove four capscrews (82) and washers (81) securing motor assembly to motor adapter (1). Using a hoist to support motor, pull motor straight away from winch. Refer to ‘Motor Disassembly’ section if motor disassembly is required.

CAUTION

• **Motor eyebolt is ONLY for lifting motor. Do NOT use to lift entire winch.**

7. Remove drive shaft (16) and coupling (17).
8. If equipped, disconnect drum band brake as described below.

Manual Drum Brake:

Refer to Dwg. MHP1721 on page 53.

- a. Remove cotter pin (178) and pin (177).
- b. To disassemble further, refer to ‘Manual Band Brake Disassembly’ on page 33.

Automatic Drum Brake:

Refer to Dwg. MHP1730 on page 52.

- a. Remove capscrews (131), spacers (132) and (133).
- b. Remove and save spacer (135).
- c. Loosen two nuts (147).
- d. Remove capscrew (149), pivot bar (148) and nuts (147).
- e. To disassemble further, refer to ‘Automatic Band Brake Disassembly’ on page 32.
9. Remove any other externally mounted winch attachments. Refer to applicable section for disassembly instructions.

CAUTION

• **There are a total of eight capscrews securing the brake cover to brake housing. Two capscrews (118) hold brake assembly together but do not attach to outboard upright. Refer to Dwg. MHP1073 on page 30. Do not remove these two capscrews until brake has been separated as an assembly from the winch and directions in the ‘Disc Brake Disassembly’ section have been reviewed.**

Disc Brake Capscrews

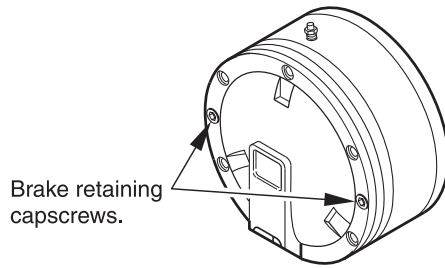

(Dwg. MHP1073)

10. Disconnect and remove brake hose (123). Remove six capscrews (117) attaching disc brake assembly to outboard upright (3). Remove disc brake assembly by tapping around housing with a soft hammer or mallet while pulling out and away from upright in a horizontal direction. Remove dowel pin (92) and store until reinstallation. To further disassemble disc brake assembly, refer to Dwg. MHP1579 on page 50 and 'Disc Brake Disassembly' section.
11. **On standard winches:** Using a hoist to support the drum, remove sideframes (12), one at a time, by removing four capscrews (14) and washers (15) attaching each sideframe to uprights (2) and (3).
12. **On Open Frame (Face) winches:** Using a hoist to support drum, remove rear sideframe (12) by removing four capscrews (14) and washers (15) attaching sideframe to uprights (2) and (3). Remove support bars (272) and sideframes (271) and (276) as an assembly by removing four capscrews (6) and washers (15). To separate bars from sideframes, remove capscrews (277). Refer to Dwg. MHP1374 on page 64.
13. Remove inboard (motor end) upright (2) by pulling straight away from drum (4) in a horizontal direction. Remove oil seal (8) and bearing (7) from upright. Discard oil seal. Discard bearing if inspection indicates replacement.
14. If equipped, remove drum band brake assembly (134) or (181) by sliding over the end of drum (4) flange. To further disassemble drum brake, refer to the appropriate 'Manual Drum Band Brake Disassembly' or 'Automatic Drum Band Brake Disassembly' section.
15. Remove outboard (disc brake end) upright (3) by pulling straight away from drum (4) in a horizontal direction. Remove oil seal (8) and bearing (7) from upright. Discard oil seal. Discard bearing if inspection indicates replacement.

⚠ CAUTION

• **Ensure reduction gear oil is drained before disassembly and that drain and fill plugs are removed. When using jacking bolts, ensure cover lifts evenly by turning bolt one full turn and then repeating on the other bolt. If cover jams, remove jacking bolts and gently tap around cover to reseal it before starting over. Careful prying of cover along its diameter during jacking, using a soft material wedge, to guide cover is acceptable. Care must be taken not to scar, gouge or damage machined finishes on cover and reducer housing mating surfaces during parts separation.**

16. Stand drum on end with reduction gear on top. Remove reduction gear assembly (20) from drum (4) by removing six capscrews (6) attaching end cover (29) to drum.
17. Screw two 7/16 - 20 UNF x 1-1/2 inch capscrews into threaded holes in cover (29). Turn both screws evenly until cover is separated from housing. Remove cover.

18. Screw two 1/2 - 13 UNC x 1-1/2 inch capscrews into threaded holes in reducer housing (22). Turn both screws evenly until housing is separated from drum. Attach suitable lifting eyes to capscrews and remove housing from drum.
19. To further disassemble reduction gear refer to 'Reduction Gear Disassembly' section.

FA2B Control Valve Removal

Refer to Dwg. MHP1794 on page 54.

1. Turn off air supply to valve and disconnect main air supply line at winch.
2. Disconnect disc brake air line from fitting located on control valve.
3. Remove muffler and/or exhaust piping.
4. Remove capscrews (88) and washers (218) and lift off control valve assembly.
5. Remove and discard gaskets (222).

FA2B Control Valve Disassembly

Refer to Dwg. MHP1794 on page 54.

Handle Removal

1. Carefully pry off plug (232).
2. Remove capscrew (201) and washer (202).

NOTICE

• **Observe spring (229) connection during disassembly. This spring is under tension and is required to return handle to neutral position.**

3. Carefully pull handle assembly from reverse valve (225). Remove spring (229).
4. Using a suitable wrench, remove handle post (237) from valve handle (231). Separate spring (236) and slide handle (235).

Reverse Valve Removal

1. Remove capscrews (228), (233) and washers (234) from seal bracket (227). Remove seal bracket from housing. Remove and discard seal (226) and 'O' ring (214).
2. Remove capscrews (201) and washers (202) from exhaust flange (213). Remove flange from housing. Remove and discard 'O' ring (214).
3. Push reverse valve (225) together with valve bushing (224) and ball (246) out handle side of housing.

NOTICE

• **Guide pin (223) allows the bushing to be removed only from the handle side of housing. Ball (246) retains reverse valve (225) in bushing (224).**

Poppet and Piston Removal

1. Remove capscrews (201) and washers (202) from piston cover (243). Remove cover and discard gasket (244).
2. Remove capscrews (201) and washers (202) from poppet cover (203). Remove cover and discard gasket (204).
3. Remove the following items from housing poppet bore: spring (205), poppet cap (206), poppet seal (207), poppet shaft (208), piston seal (242) and piston (241). Remove and discard 'O' ring (239).
4. Using finger, from reverse valve bore, push pilot rod assembly out of housing.

5. Separate pilot rod assembly by removing retainer (247) and spring (252). Lift pilot rod assembly out of pilot seat (248).

FA2B Motor Disassembly

Refer to Dwg. MHP1796 on page 44.

NOTICE

- **Internal components of the motor are machined to very close tolerances. Ensure that work area and parts are kept very clean to prevent damage or contamination of components.**
- **Motor capscrews are 13 mm.**

1. Disconnect air line to winch.
2. Remove muffler.

WARNING

- **The air motor weighs approximately 145 lbs (66 kg). Adequately support the air motor before removing the motor mounting capscrews.**

3. Use a suitable hoist to support the motor assembly.

CAUTION

- **Motor eyebolt is ONLY for lifting motor. Do NOT use to lift entire winch.**

4. Remove capscrews (82) and washers (81). Pull motor straight away from motor adapter (1).
5. Place motor on a suitable clean bench with rotary housing assembly (58) facing up.
6. Remove capscrews (56) and washers (37) from rotary housing cover (51). Remove cover and gasket (52). Discard gasket.
7. Remove capscrews (56) and washers (37). Lift rotary housing assembly (58) up off motor housing (72). Remove and discard gasket (62).
8. Remove retainer (53) and press rotary valve (64) out of housing.
9. Pull bearings (63) and (54) out of rotary housing.
10. Press rotary valve bushing (61) out of rotary housing.
11. Remove capscrews (56) and washers (37) from cylinder caps (79). Remove caps and gaskets (78). Discard gaskets.
12. Lift out cylinders (77). Piston rings (76) will fall free when clear of cylinder.
13. Carefully rotate crankshaft (66) until piston assembly (73) is centered in motor housing (72). Lift piston assembly straight up. Repeat for remaining piston assembly.
14. Remove retainer ring (69) and press crankshaft (66) out of motor housing (72).
15. Remove retainer ring (68) and press out bearing (67).

HU40A Winch Motor Disassembly

Refer to Dwg. MHP1720 on page 60 and MHP1827 on page 46.

WARNING

- **HU40A motor weighs approximately 100 lbs (45 kg). Adequately support the air motor before removing the motor mounting screws.**

1. Remove capscrews (713) and washers (714). Pull motor away from upright and take to a clean workbench.
2. Remove capscrews (762) and washers (761). Pull control valve assembly off of motor housing (715). To disassemble further, refer to 'HU40A Control Valve Disassembly' and Dwg. MHP1720.
3. Pry baseplate (729) away from motor housing (715). Remove seal (732) and discard.
4. Remove capscrews (704) and washers (705). Remove cylinder heads (706) and gaskets (707), discard gaskets.
5. Select a piston (710), which is at the highest position. Press this liner (708) out of motor housing. Remove retainer ring (702) from one side of piston (710) and press wrist pin (703) out of piston.

NOTICE

- **Match mark this piston and liner if going to be used for assembly.**

6. Rotate crankshaft assembly until each piston is at its highest position and then repeat the step above for each of the remaining pistons.
7. Carefully pull crankshaft assembly out of motor housing. Match mark connector rods (731) and crankshaft assembly (720) if going to be reused during assembly.
8. Pull bearings (716) and (728) off both ends of crankshaft assembly (720).
9. Remove cotter pin (718) and nut (719). Press out pin (717) and separate crankshaft halves.
10. Remove one ring (721), connector rods (731), sleeve (723), bushing (722) and second ring (721).

HU40A Winch Valve Disassembly

Refer to Dwg. MHP1720 on page 60 and MHP1827 on page 46.

1. Remove capscrews (762) and washers (761). Pull valve assembly off of motor housing.
2. Separate cover (759) and press rotary valve (768) out of valve chest (765).
3. Remove valve cap (751). Lift out spring (753).
4. Tip valve housing over and remove poppet assembly and ball (758).

NOTICE

- **If poppet assembly needs to be disassembled, retainer (752) will be destroyed.**

5. Remove retainer (752) and separate throttle valve (755) and poppet (757).

⚠ CAUTION

- Spring (763) is under tension, use care when removing from stop pins (781).

NOTICE

- Observe orientation of spring (763) for use during assembly.
6. With ball (758) removed, reversing valve (778) and handle assembly can be removed from valve chest.
 7. Separate handle assembly from reversing valve and remove spring (763).
 8. Remove setscrew (776), spring (775) and throttle lever latch (774).
 9. Remove cotter pin (718), press pin (772) out of throttle control arm (771) and separate throttle lever (773).

AMP94A Winch Motor Disassembly

Refer to Dwg. MHP1845 on page 48.

⚠ WARNING

- The AMP94A winch motor weighs approximately 117 lbs (53 kg). Adequately support the air motor before removing the motor mounting screws.

1. Remove capscrews (821), lockwashers (819) and exhaust cover (818). Pull out rotary valve (816) and rotary bushing (815). Remove adapter valve (817).
2. Remove capscrews (801), copper washers (802) and cylinders (803) from the motor housing (813).
3. Rotate crankshaft assembly (829) to raise piston (805) until wrist pin (807) is above motor housing (813). Push out wrist pin and plugs (806) as an assembly.
4. Remove compression rings (804) carefully to avoid breaking rings. Remove oil rings (808).
5. Repeat steps 3 and 4 for remaining pistons.
6. Pull crankshaft assembly (829) with attached connecting rods (809) out of motor housing (813) by shifting the connecting rods to clear the cylinder holes. Connecting rods are assembled on crankshaft and held in place by connecting rod links that cannot be disassembled until removed from motor housing.
7. Remove setscrew (828) and drive out taper pin (825) securing counterbalance to crankshaft. Loosen capscrew (826) until counterbalance can be removed. Separate connecting rod rings (831), connecting rods (809), bushing (832) and sleeve (833).

AMP94A Winch Valve Disassembly

Refer to Dwg. MHP1844 on page 62.

NOTICE

- Prior to disassembly, matchmark valve parts to ensure proper arrangement during reassembly.

1. Remove cotter pin (859) and tap out pin (861) from handle bracket (857).

2. Mark the square end on the valve body (872) and the handle bracket (857) to ensure correct orientation during reassembly. Remove handle assembly.
3. Note spring (858) position for reassembly. Remove spring (858). Remove capscrews (875), lockwashers (874) and exhaust cover (873) from housing (868).
4. Remove pipe plug (866), spring (853), poppet valve (867) and ball (852) from housing.
5. Check clearance between valve bushing (871) and valve (872). Clearance should not exceed 0.002 inch (0.05 mm) or excessive air leakage will occur.
6. Pull valve (872) out valve bushing (871). Check parts for score marks and wear.

Disc Brake Disassembly

Refer to Dwg. MHP1579 on page 50.

NOTICE

- Prior to disassembly, matchmark the cover (114), housing (108) and support plate (96) to assist in proper alignment of parts during reassembly.

1. Remove brake shaft (91) and retainer ring (93). Place brake assembly on a flat surface with cover (114) on top. Remove elbow fitting (116) and exhaust valve (115). Alternately and evenly loosen the two capscrews (118) until the brake spring (97) compression has been relaxed. Remove capscrews.
2. Remove cover (114) and diaphragm (113).
3. Using a small-tipped screwdriver or similar tool, remove ring (112). Remove diaphragm support (111).
4. Remove housing (108) by lifting straight away from brake parts. Collect the three dowel pins (106) and store until reinstallation. Inspect pins for deformation, wear and damage. Replace if parts fail inspection.
5. Alternately remove the six separator plates (103) and five friction plates (102).
6. Remove pressure plate (101) and springs (97).
7. Grasp outer race (104) and remove sprag clutch as an assembly. Remove spacer (98) between the sprag clutch assembly and support plate (96).
8. Remove gasket (34) from support plate (96). Discard gasket.
9. To remove bearing (95) from support plate (96) first remove retainer ring (94) and then press bearing out of the support plate bore.

NOTICE

- To prevent accidental damage, remove bearing (95) only if it requires replacement.

10. Separate sprag clutch assembly into its component parts. The sprag clutch assembly consists of an inner race (105), two spacers (98), outer race (104) and sprag clutch (99). The sprag clutch can be further disassembled into two wearing plates and the sprag cage.

Automatic Drum Band Brake Disassembly

Optional feature. Refer to Dwg. MHP1730 on page 52.

1. Loosen jam nut (147) closest to plunger (144). Turn capscrew (149) counterclockwise until disconnected from plunger.

2. Disconnect air line (123) from exhaust valve (115). Remove exhaust valve from brake cylinder (151). With the aid of a strap wrench, remove brake cylinder (151) and components as an assembly by turning brake cylinder counterclockwise until disconnected from brake bracket (136).
3. Disconnect brake bracket (136) from band assembly by removing three capscrews (131), spacers (132) and spacer tubes (133). Remove spacer plate (135).
4. Disconnect brake bracket from motor end upright (2) by removing two capscrews (137) and two capscrews (142).

DANGER

• **Springs (154) and (157) exert a considerable force on cover (155). Extreme care must be taken when disassembling the cylinder assembly and removing cover (155).**

5. To disassemble cylinder (151) assembly into its component parts conduct the following:
 - a. Use a press to compress cover (155) enough to remove retainer ring (156). Slowly, and carefully, relax the load exerted on cover (155) by springs (154) and (157). Remove cover and springs.
 - b. Remove washer (158).
 - c. Remove piston (153) assembly.
 - d. Disassemble piston assembly into component parts by removing retainer ring (141) and separating cylinder rod (138) from piston (153). Remove 'O' rings (152), (139) and (140). Discard 'O' rings.
6. Remove plunger (144) assembly and spring (143) from brake bracket (136).

Manual Drum Band Brake Disassembly

Optional feature. Refer to Dwg. MHP1721 on page 53.
The winch does not have to be removed or disassembled to disassemble the manual band brake.

CAUTION

• **Release wire rope tension on the drum and disconnect main air supply line.**

1. Raise handle (173) to free brake bands (181).
2. Remove cotter pin (178) and pin (177).
3. Rotate brake link stud (179) counterclockwise until free from brake handle.
4. Remove grip from brake handle (173). Loosen screws in brake handle until handle can be freed from brake band bracket, remove brake handle. Remove pivot nut (174).
5. Remove cotter pin (175) and washer (183).
6. Loosen capscrews (171).
7. Spread brake band (181) apart slightly and slide out over drum flange. Rotate brake band around drum and remove.
8. Repeat this procedure for other half of brake band (181).
9. Remove capscrews (171), washers (172), and adapter plate (176).
10. Press bushings (182) out of brake band pivot brackets.

Reduction Gear Disassembly

Refer to Dwg. MHP1565 on page 42.

1. Remove thrust bearing (28) from either cover (29) or planetary gear assembly (27).

2. Pull planetary gear assembly (27) out of reducer housing (22).
3. Pull sun gear (26) out of reducer housing, planetary gear assembly (25) will be attached.
4. Remove retainer ring (24) and separate sun gear and planetary gear assembly.
5. Pull sun gear (23) out of reducer housing.
6. Remove retainer ring (19), seal (18) and second retainer ring (19). Pull bearing (21) from rear of reducer housing. Do not disassemble planetary gear assemblies any farther.

Free Spool Disassembly

Optional feature. Refer to Dwg. MHP1828 on page 66.

1. Relieve pressure in air lines and winch air components by operating winch control several times after air supply has been turned off.

WARNING

• **Shut off, bleed down and disconnect air supply line before performing any disassembly procedures.**
• **Do not attempt repairs with load on wire rope.**

2. To assist in reassembly, place match marks on housing (502) and outboard upright (3).
3. Remove capscrews (513) and pull free spool shifter assembly (507) out of housing (502).

NOTICE

• **Spring (509) is compressed by handle (512). During disassembly do not lose latch (511) when pin (508) is removed.**

4. Press down on base of handle (512) and, using a pin punch or similar tool, drive out dowel pin (508). Separate parts: handle, latch (511), detent plate (514) and shifter (515).
5. Remove 'O' ring (501) from housing (502). Discard 'O' ring.
6. To remove dowel pin (516) from shifter (515) the pin must be heated to loosen the Loctite® bond.
7. Remove capscrews (36) and washers (37) securing cover (35) to housing (502).
8. Separate cover from housing. Remove and discard gasket (34).
9. Remove capscrews (505) securing housing to upright (3). Pull housing away from upright while pushing shaft support (503) towards upright until housing is removed.
10. Remove capscrews (504) and pull shaft support away from output shaft (32).

Cleaning, Inspection and Repair

Cleaning

Clean all winch component parts in solvent (except drum brake bands and disc brake friction plates). The use of a stiff bristle brush will facilitate removal of accumulated dirt and sediments on housings, frame and drum. If bushings have been removed it may be necessary to carefully remove old Loctite® from bushing bores. Dry each part using low pressure, filtered compressed air. Clean drum brake band using a wire brush or emery cloth. Do not wash drum brake band in solvent. If drum brake band lining is oil soaked, it must be replaced.

Inspection

All disassembled parts should be inspected to determine their fitness for continued use. Pay particular attention to the following:

Inspect **gears** for

- worn, cracked or broken teeth. If evident, replace.

Inspect **bushings** for

- wear, scoring or galling. If evident, replace.

Inspect **shafts** for

- ridges caused by wear. If evident, replace.
- scoring or galling.

Inspect **all threaded items** for

- damaged threads. If evident, replace.

Inspect **drum band brake lining** for

- oil, grease and glazing. If drum band brake lining is oil-soaked, excessively greasy or overly glazed replace brake band. Remove small glazed areas of band brake lining by sanding lightly with a fine grit emery cloth.
- thickness of drum band brake lining. If drum brake band lining is less than 0.062 in. (2 mm) thick anywhere along the edges replace brake band assembly.

Inspect **motor cylinder bores** for

- wear. Cylinders can be lightly honed. For any large scratches or wear patterns, replace cylinder assembly.

Inspect **FA2B motor rotary valve (62) and rotary bushing** for

- clearance between valve and bushing. Nominal gap is 0.00125-0.00225 inch (0.0318-0.0572 mm) per side for a total of 0.0025-0.0045 inch (0.0635-0.1143 mm). If gap is greater than 0.0025 inch (0.064 mm) per side, or greater than 0.005 inch (0.127 mm) total replace rotary bushing.
- rotary valve and bushing should not come into contact. If contacting, bushing may be honed to eliminate the interference. Bearings on end of rotary valve may be cause of contact; check bearings (63) and (54) for excessive play and proper press fit. Replace bearings if required.
- any time bushing or valve is replaced, replace bearings.

Inspect **piston/connecting rod assembly** for

- wear, scoring. Replace if either condition exists.
- connecting rod should operate smoothly without binding and without excessive side to side play.

Inspect **bearings** for

- all motor bearings are factory lubricated and sealed. Inspect for loss of grease and evidence of grit, dirt or other contaminants. If dry or contaminated, replace the bearing.
- Inspect crankshaft roller bearings (needle). At any indication of damage, or contamination replace bearings.

Inspect **crank pin bushing**, located in rotary valve, for

- wear, scoring or damage. Replace if either condition exists.
- if bushing is not flush with outside face of rotary valve or is damaged it should be removed and replaced.

Inspect **disc brake** for

- wear. Replace brake discs if grooving pattern is no longer visible or if discs are cracked or chipped.

Repair

Actual repairs are limited to the removal of small burrs and other minor surface imperfections from gears, shafts, housings and machined surfaces. Use a fine stone or emery cloth for this work.

1. Worn or damaged parts must be replaced. Refer to applicable parts listing for specific replacement parts information.
2. Inspect all remaining parts for evidence of damage. Replace or repair any part which is in questionable condition. The cost of the part is often minor in comparison with the cost of redoing the job.

3. Smooth out all nicks, burrs, or galled spots on shafts, bores, pins, or bushings.
4. Examine all gear teeth carefully, and remove nicks or burrs.
5. Polish edges of all shaft shoulders to remove small nicks which may have been caused during handling.
6. Remove all nicks and burrs caused by lockwashers.

Assembly

General instructions

- use new gaskets and seals.
- replace worn parts.
- assemble parts using match marks applied during disassembly. Compare replacement parts with originals to identify installation alignments.
- lubricate all internal parts with rust and oxidation inhibiting lubricant, ISO VG 100 (30W SAE).

Thermoplastic Coated Parts Assembly

⚠ CAUTION

• **During application of thermoplastic coating to assemblies use a flame to localize heat. Do not heat entire assembly. Assemblies contain gaskets, 'O' rings and other components that may be damaged by exposure to excessive heat.**

1. When assembling parts already coated, mating areas can be heated to soften coating enough to flow together and seal parts.
2. When installing a new component in an assembly, remove coating from existing parts as necessary to ensure parts mate correctly.
3. Install fasteners and torque as required. Apply coating to bare areas as described in 'Thermoplastic Coating' repairing surfaces instructions in the "MAINTENANCE" section for areas larger than 1/16 inch (1.6 mm).
4. Allow repaired area to cool. Quenching with water is acceptable. Rough spots, minor scorching and excess coating deposits can be wet sanded to remove imperfections. To return the gloss finish, reheat surface carefully.

FA2B Winch Motor Assembly

Refer to Dwg. MHP1796 on page 44.

1. Press bearing (67) into motor housing (72) and secure with retainer ring (68).
2. Press crankshaft (66) through bearing (67) and secure with retainer ring (69).
3. Lubricate 'O' rings (75) and place in grooves on piston heads.

NOTICE

• **Ensure piston needle roller bearings are contaminant-free. Lubricate bearings with a molybdenum-lithium based grease ("Lubriplate, Mo-Lith #2" recommended).**

4. With eyebolt on motor housing oriented UP, place a piston assembly (73) on crankshaft pin with connecting rod pointing DOWN. Refer to Dwg. MHP1837 on page 35.

Piston to Crankshaft Assembly

Eyebolt
is UP

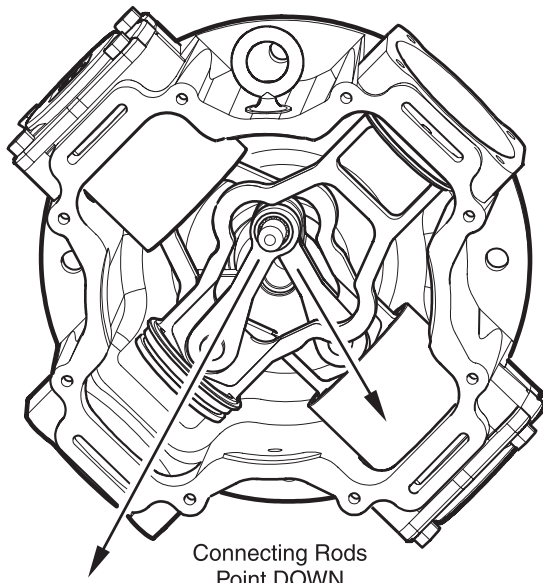

(Dwg. MHP1837)

NOTICE

• Coat inside of cylinders and motor housing cylinder bores with lightweight grease (synthetic PTFE-based silicone lubricant recommended).

5. Place a piston ring set (76) over one piston and compress with fingers. When correctly installed, rings snap together. Insert one cylinder (77) through motor housing and over these rings. Repeat for other piston.
6. Orient stud on cylinder to the back of motor. This will align ports in cylinder with those in motor housing.
7. Place a gasket (78) and cylinder cap (79) on each cylinder. There is a recess in cap for cylinder stud to fit in, to maintain cylinder alignment during operation. Loosely secure with washers (37) and capscrews (56). Repeat for opposite cylinder.
8. Rotate crankshaft and repeat steps 2 through 7 for the other piston assembly.
9. Once both piston assemblies and liners are installed, tighten capscrews (56).
10. Check rotation of crankshaft assembly. Assembly should rotate smoothly without sticking, binding or knocking of the piston heads on the top of the cylinders. Correct any problems before continuing assembly.
11. Press rotary valve bushing (61) into rotary housing (58). Ensure pin in housing and slot in bushing align correctly. Press until bushing is flush.
12. Press bearing (63) into rotary housing.
13. Install retainer ring (55) into rotary housing.
14. Press rotary valve (64) through bearing (63) and into rotary housing.
15. Press bearing (54) onto rotary valve and into rotary housing. Secure with retainer ring (53).

CAUTION

• During installation of bearing (54), support both the inner and outer race of bearing.

16. Check rotation of rotary valve. Rotation should be smooth without sticking or binding. Correct any problems before continuing assembly.
17. Position pin in crankshaft (66) at the top (closest to eyebolt). Place gasket (62) on motor housing. Lift rotary housing onto motor housing (counterweight of the rotary valve will rotate to the bottom). Align pin in the crankshaft with hole in rotary valve and place both housings together.
18. Secure with washers (37) and capscrews (56).
19. Align gasket (52) and rotary housing cover (51) with holes in rotary housing (58) and secure with washers (37) and capscrews (56).

FA2B Control Valve Assembly

Refer to Dwg. MHP1794 on page 54.

Poppet and Piston Assembly

1. Insert pilot rod (249) into pilot seat (248). Place spring (252) over exposed pilot rod and secure with retainer (247).
2. Lubricate 'O' ring (239) and place onto piston (241).
3. Place piston seal (242) in piston and insert into poppet bore in valve housing (245) from handle side.
4. Insert poppet shaft (208) through front of housing, ensuring that shaft is seated in piston seal.
5. Place poppet seal (207) into poppet cap (206); insert this assembly into poppet bore in valve housing from the front. Ensure that assembly is seated on poppet shaft.
6. Insert spring (205) into the front of the poppet bore and secure with poppet cover (203), gasket (204), capscrews (201) and washers (202).
7. Check poppet assembly by pushing piston (241). Piston should travel 0.375 inch (9.5 mm) and return when released. Secure piston cover (243) to housing with gasket (244), washers (202) and capscrews (201).
8. Insert plug (251) into top port in valve housing and secure.

Reverse Valve Assembly

1. Insert reverse valve (225) into bushing (224) with ball slot oriented UP. Apply grease to ball (246) and insert into ball slot of reverse valve (225) through bushing (224).
2. Insert valve bushing (224), reverse valve (225) and ball (246) into valve housing from handle side, ensuring that groove in bushing is aligned with pin (223).
3. Lubricate 'O' ring (214) and place it in groove in exhaust flange (213).
4. Secure exhaust flange (213) to valve housing using capscrews (201) and washers (202).
5. Insert seal (226) into seal bracket (227). Lubricate 'O' ring (214) and place into groove in seal bracket.
6. Place seal bracket over end of reverse valve. Using finger pressure, press until seal is seated on reverse valve and seal bracket is seated on valve housing. Secure with washers (234) and capscrews (228), (233).

NOTICE

- **Do not rotate reverse valve more than 40° left or right. Ball (246) will wedge between reverse valve (225) and bushing (224), requiring removal of reverse valve (225) and bushing (224) to access ball.**

Handle Assembly

1. Grease valve handle (231) shaft; place slide handle (235) over valve handle (231). Insert spring (236) into slide handle (and over valve handle).
2. Place handle post (237) over this assembly and tighten.
3. Place ball (238) on handle post (237) and tighten.
4. Place spring (229) over reverse valve handle end in seal bracket.

NOTICE

- **Spring will have to be 'Cocked' over stud in seal bracket. This will ensure handle returns to neutral.**

5. Place handle assembly over reverse valve end. Slide handle will have to be lifted slightly to allow pin to fit into slot in seal bracket.
6. Secure handle assembly to reverse valve with washer (202) and capscrew (201). Press plug (232) into handle assembly to cover capscrew. Check rotation of reverse valve. Correct any discrepancies.

HU40A Winch Motor Assembly

Refer to Dwg. MHP1720 on page 60 and MHP1827 on page 46.

NOTICE

- **During assembly coat all surfaces with light grease.**

1. Press bearing (728) onto crankshaft (720) half with pin. Press bearing (716) onto crankshaft half with counterweight only.
2. Place bushing (722) and sleeve (723) onto crankshaft pin, followed by ring (721).
3. Insert connecting rods (731) into this ring and secure with second ring (721).
4. Align groove in crankshaft pin with bore in counterweight and press counterweight onto crankshaft pin. Secure with pin (717). Place nut (719) on pin (717) and tighten. Secure this nut by installing cotter pin (718) and bending ends apart.
5. Carefully insert this assembly into motor housing (715).
6. Place compression ring (709) in top groove of piston (710), using a ring compressor, compress the ring and slide liner (708) over the ring (DO NOT cover wrist pin bore).
7. Select a connecting rod that is at its highest position and place this piston assembly over it, aligning connecting rod end with wrist pin bore. Insert a wrist pin and secure with retainer rings (702).
8. Place oil ring (711) in lower groove of piston and using ring compressor, compress oil ring. Push liner down over oil ring. Insert liner into motor housing. Place gasket (707) and cylinder cap (706) over liner and loosely secure with washers (705) and capscrews (704).
9. Repeat this for the other pistons. Tighten all capscrews (704).

10. Insert seal (732) into baseplate (729). Ensure seal lip is facing towards motor. Place baseplate onto motor housing.
11. Using capscrews (713) and washers (714) secure motor housing assembly and baseplate to motor adapter (1).

HU40A Winch Valve Assembly

Refer to Dwg. MHP1720 on page 60 and MHP1827 on page 46.

1. Place throttle lever (773) and throttle control arm (771) together and secure with pin (772) and cotter pins (718).
2. Insert throttle lever latch (774) into throttle lever followed by spring (775) and secure with setscrew (776).
3. Insert reversing valve (778) into handle assembly. Cock spring (763) and place over reversing valve and on stop pin (781).

CAUTION

- **Spring (763) is under tension, use care when placing on stop pins (781).**

4. Carefully insert this assembly into valve chest (765).
5. Drop ball (758) into top port of valve chest. This ball holds reversing valve and handle assembly in valve chest.
6. Place throttle valve (755) on poppet (757) and secure with retainer ring (752).
7. Insert poppet assembly into top port followed by spring (753) and secure with valve cap (751).
8. Insert rotary valve (768) into motor side of valve chest, leave about 0.5 inch (13 mm) of valve exposed.
9. Place valve chest assembly onto motor housing. Align rotary valve and pin (769) with crankshaft and then secure valve chest assembly with capscrews (762) and washers (761).

AMP94A Winch Motor Assembly

Refer to Dwg. MHP1845 on page 48.

1. Press bearing (814) onto crankshaft counterbalance (829). Place connecting rods (809) on bushing (832) and hold them in place with the two connecting rod rings (831). Install connecting rod rings (831) so the chamfered side is next to connecting rod (809).
2. Place sleeve (833) on crankshaft (829), then install connecting rod assembly on crankshaft.
3. Secure crankshaft counterbalance to crankshaft with taper pin (825). Install setscrew (828). Tighten capscrew (826).
4. Attach rotary valve (815), adapter valve (817) and exhaust cap (818) to motor housing (813) with two capscrews (821). This is necessary to correctly locate bearing (814) when installing crankshaft in motor housing (813), shifting it as necessary such that each connecting rod (809) end will project through a cylinder hole.
5. Align bearing (814) in bore of motor housing (813) and tap crankshaft assembly in place until bearing bottoms on rotary valve bushing.
6. Check the fit of each compression and oil ring by placing one ring at a time in cylinders, making sure that ring is not canted or tilted in relation to the cylinder wall. With a feeler gauge, measure the ring gap.
7. Make sure that compression rings (804), oil rings (808), and pistons (805) are absolutely clean. Carefully place oil rings (808) and compression rings (804) in their respective grooves on the pistons (805).

NOTICE

• **Do not interchange compression and oil rings. Compression rings (804) must be placed near piston (805) head. Oil rings (808), identified by several oil channel grooves, must be placed nearest piston (805) skirt. Refer to Dwg. MHP0224 on page 37.**

8. Compression and oil ring joints must be staggered and positioned such that joints (gaps) do not coincide with wrist pin (807) openings. Refer to Dwg. MHP0224 on page 37.
9. Rotate crankshaft so each connecting rod (809) in succession will project enough beyond motor housing (813) to permit inserting wrist pin (807) through piston (805) and connecting rod (809).
10. After each piston (805) is assembled to its connecting rod (809), install a gasket (811) and cylinder (803).
11. Slide each cylinder (803) over piston (805), guiding it carefully over compression and oil rings. Note that cylinder has four tapered ears around skirt of piston which serve as ring compressors to aid in installation. Cylinders should fit into place by tapping lightly. If force is required, there may be an alignment problem which must be corrected before continuing.
12. Secure cylinders (803) to motor housing (813) by uniformly tightening capscrews (801) and copper washers (802).
13. Remove exhaust cap (818). Install rotary bushing (816) and rotary valve (815) in adapter valve (817). Align drive pins on rotary valve (816) with the end of crankshaft (829). The three drive pins on crank shaft end of the rotary valve should fit in the holes in crankshaft without appreciable play. If holes in the crank shaft are elongated, crankshaft should be replaced. The drive pins are located such that rotary valve will always be returned to correct position.
14. Install exhaust cap (818) and secure in position with capscrews (821) and lockwashers (819).

Piston Ring Installation

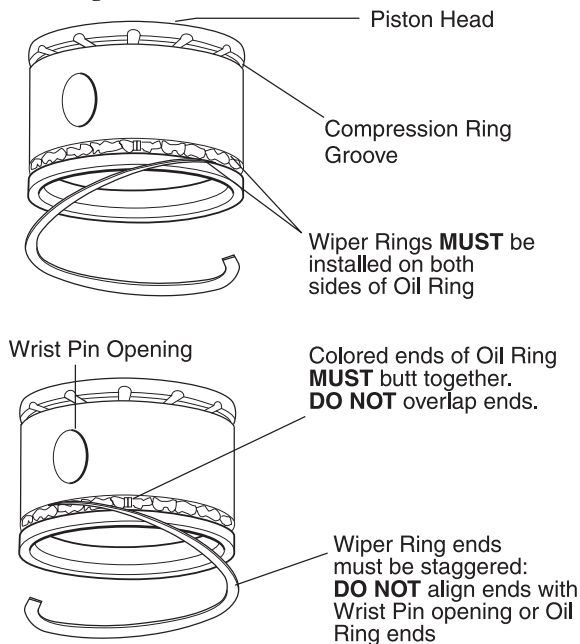

(Dwg. MHP0224)

AMP94A Winch Valve Assembly

Refer to Dwg. MHP1844 on page 62.

NOTICE

• **During assembly align parts using match marks made during disassembly.**

1. Install valve (872) and valve bushing (871) into housing (868).
2. Install ball (852), poppet valve (867), spring (853) and pipe plug (866) in housing (868).
3. If screws (862) were removed during disassembly, reinstall in housing (868) and handle bracket (857).
4. Place spring (853) and ball (852) in handle bracket (857). Depress spring and ball with handle (851) and install pin (856) with washers (82) and cotter pins (854). Bend cotter pin ends apart.
5. Install spring (858) and handle assembly on square shaft of valve (872) aligning match marks made during disassembly. Spring (858) end must straddle screw (862) on handle bracket (857). Secure handle assembly to valve with pins (861) and (859).
6. Install sleeves (864) and capscrews (863) on housing (868). Attach exhaust cover (873) to housing (868) with capscrews (875) and lockwashers (874).
7. Check throttle handle moves fully left and right without sticking or binding. Throttle handle should center, by spring force, automatically when released.

Reduction Gear Assembly

Refer to Dwg. MHP1565 on page 42.

1. Press bearing (21) in to rear of reducer housing (22) and secure with retainer ring (19).
2. Press seal (18) behind this retainer (with lip facing towards reducer housing), secure with second retainer ring (19).
3. Insert sun gear (23) into reducer housing.
4. Place one retainer ring (24) onto sun gear (26). Insert this assembly into planetary gear assembly (25) and secure with second retainer ring (24). Insert this assembly into reducer housing.
5. Insert planetary assembly (27) into reducer housing. Place thrust washer (28) onto planetary gear assembly.
6. With drum (4) on end (reduction gear side UP), place a continuous bead of Loctite® 515 around drum bolt hole pattern.
7. Align bolt holes in drum and reducer housing and lower reducer housing into drum.
8. Place a continuous bead of Loctite® 515 around reducer housing bolt hole pattern. Align bolt holes in cover (29) with reducer housing and secure with capscrews (6).

Winch Assembly

Refer to Dwg. MHP1374 on page 64 and MHP1565 on page 42.

NOTICE

• **Unless otherwise stated capscrew torque values listed are for Teflon plated threads. Winches use “blue bolts” in numerous locations. These are Teflon plated and should not be lubricated.**

1. Using a hoist, support the drum.
2. Install bearing (7) in inboard (motor end) upright (2). With oil seal (8) lip facing towards the motor, install oil seal in inboard upright.
3. Install output shaft (32), bearing (7) and oil seal (8) in outboard upright (3). Oil seal lip must face toward the brake. Install outboard upright onto drum by aligning splines of output shaft to reduction gear output carrier assembly splines.
4. If equipped with automatic drum brake, install drum band brake bracket and piston assemblies. Do not attach brake band assembly (181) or (134). Refer to 'Drum Band Brake' section for instructions.
5. Install coupling (17) on drive shaft (16) and install on end of input sun gear (23), located in reduction gear assembly.
6. If equipped with automatic drum brake, place brake band assembly (181) or (134) onto drum brake flange. Place inboard (motor end) upright (2) on drum.
7. **For standard winch:** loosely attach sideframes (12) to uprights (3) and (2) using four capscrews (14) and washers (15) for each sideframe. Tighten capscrews and torque to 35 ft lbs (48 Nm).
8. **For Open Frame (Face) winch:** Refer to Dwg. MHP1374 on page 64.
 - a. Loosely attach rear sideframe (12), using four washers (15) and capscrews (14) to uprights (2) and (3).
 - b. Place open frame assembly onto uprights (2) and (3). Ensure sideframe (276) is located on upright (2) and sideframe (271) is located on upright (3). Place washers (15) on capscrews (6) and secure frame assembly to uprights. Torque capscrews to 35 ft lbs (48 Nm).
 - c. Secure rear sideframe (12) to uprights, torque capscrews (14) to 35 ft lbs (48 Nm).
9. Align holes in motor adapter (1) and install on upright. Secure with six washers (39) and capscrews (38). Torque capscrews to 12 ft lbs (16 Nm).
10. If equipped, attach band brake assembly (181) or (134) as described in the 'Drum Band Brake Assembly' section.

Disc Brake Assembly

Refer to Dwg. MHP1579 on page 50.

1. Install bearing (95) into support plate (96) and secure with retainer ring (94).
2. In this order, place spacer (98), sprag clutch (99), outer race (104) and spacer (98) on inner race (105). Test sprag clutch operation. Refer to Dwg. MHP1830 on page 38.

NOTICE

• **Correct sprag clutch installation prevents clockwise rotation (brake engages) and allows counterclockwise rotation when viewed from end cover (114) end of brake assembly.**

⚠ WARNING

• **Incorrect assembly of sprag clutch will adversely affect winch operation. In haul-in operation, sprag clutch will be engaged resulting in restricted winch operation. In neutral and payout positions, sprag clutch can rotate resulting in brake not holding load. Ensure sprag clutch is correctly installed.**

3. Install assembly on support plate (96).

4. Install six springs (97) in holes on inside of support plate (96).
5. Install gasket (34) and pressure plate (101).
6. Determine correct alignment of end cover (114), housing (108) and support plate (96) by checking matchmarks placed during disassembly, or by placing housing on support plate and matching capscREW holes.

Sprag Clutch Parts Assembly

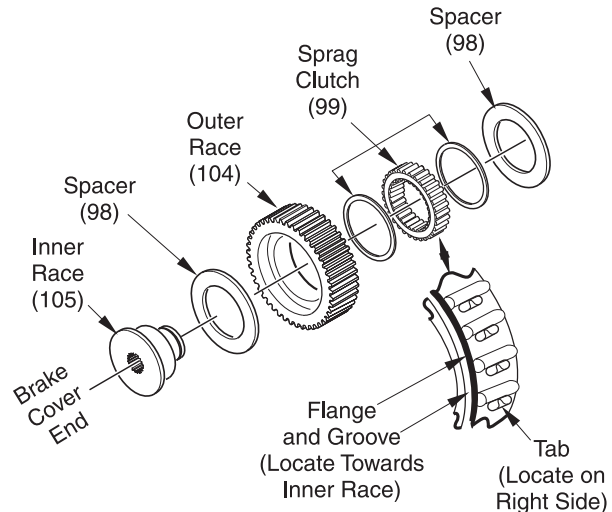

(Dwg. MHP1830)

7. Correctly align with dowel slots on housing (108) and install six separator plates (103) and five friction plates (102) in the following order:
 - a. Begin with a separator plate, followed by a friction plate. Alternate plates.
8. Install three dowel pins (106) in housing (108). Apply Loctite® 515 sealant on mating surfaces of housing and end cover (114). Install housing by aligning dowel pins with separator (103) and friction plate (102) grooves and, also aligning capscREW holes in housing with holes in end cover.
9. Install ring (112), and diaphragm support plate (111). Support plate radius must be next to diaphragm (113).
10. Install diaphragm (113) and end cover (114).
11. Locate as shown on Dwg. MHP1579 on page 50 and install two capscREWS (118). Evenly and alternately tighten capscREWS to compress springs. Torque capscREWS to 12 ft lbs (16 Nm).
12. Place a bead of Loctite® 515 around bolt hole patterns in upright and backside of support plate (96). Place gasket (34) on upright.
13. Install brake shaft (91) and place assembly on outboard (opposite motor end) upright (3). Align capscREW holes such that breather (107) is slightly off top dead center and dowel pin (92) is aligned with dowel pin hole in upright. Install six capscREWS (117). Torque capscREWS to 12 ft lbs (16 Nm). Install exhaust valve (115), elbow fitting (116) and connect air hose (123) to elbow fitting.

NOTICE

• **Dowel pin (92) will only allow FA2B, HU40A and AMP94A disc brake to be installed onto upright. Dowel pin hole in upright is located on the right hand side of hole pattern, at the 5 o'clock position. DO NOT attempt to install disc brake onto winch if the dowel pin and the locator dowel pin hole do not align.**

WARNING

• **Installation of FA2B disc brake assembly onto any other winch may result in brake failure to hold the load.**

14. Winch drum **may** rotate in haul-in direction and **must not** rotate in payout direction, unless air is applied to brake, when assembled properly.

Manual Drum Band Brake Assembly

Optional feature. Refer to Dwg. MHP1721 on page 53.

1. Press bushings (182) into brake band pivot brackets. Bushing flanges must be to motor upright side.
2. Attach adapter plate (176) to motor side upright (2) loosely with capscrews (171) (apply Loctite® 242 to threads) and washers (172).
3. Place brake band (181) onto drum and rotate around drum (close to mounting position). Spread brake band (181) apart slightly and slide in over drum flange. Place brake band pivot bracket over pin in adapter plate (176).
4. Repeat this procedure for other brake band (181).
5. Place washer (183) over pin in adapter plate (176) and secure with cotter pin (175). Bend cotter pin ends apart.
6. Insert pivot nut (174) into brake handle (173).
7. Place brake handle (173) into bracket in brake band (181) and tighten screws in handle. Slide grip over brake handle.
8. Place brake link stud (179) into pivot nut (174) and rotate clockwise until approximately 1 inch (25 mm) of threads are exposed.

NOTICE

• **Refer to ‘Adjustment’ section for instructions on adjusting brake.**

9. Lift up brake handle (173) until hole in brake link stud (179) and bracket in brake band (181) are aligned. Insert pin (177) and secure with cotter pin (178). Bend cotter pin ends apart.
10. Push brake handle (173) down to the lock position.
11. Torque capscrews (171) to 50 ft lbs (68 Nm).

Automatic Drum Band Brake Assembly

Optional feature. Refer to Dwg. MHP1730 on page 52.

For ease of assembly install bracket (136), cylinder (151) assembly and brake handle stop to motor end upright (2) prior to assembling upright to drum.

1. Assemble brake cylinder (151) as follows:
 - a. Install ‘O’ ring (152) on piston (153).
 - b. Heavily coat piston and cylinder rod with “LubriPlate” MO-LITH No. 2 or equivalent lubricant. Install ‘O’ rings (139) and (140) on cylinder rod (138). Place cylinder rod (138) into piston (153) and secure in place using retainer ring (141).
 - c. Install piston assembly in brake cylinder (151).
 - d. Install washer (158) and springs (154) and (157).

DANGER

• **Springs (154) and (157) exert a considerable force on cover (155) when assembled. Extreme care must be taken when assembling and installing cover (155) and retainer ring (156).**

- e. Using a press, slowly compress cover (155) and springs until retainer ring groove is accessible. Install retainer ring (156). To ensure that retainer ring is properly installed, tap end of retainer ring with a punch until entire retainer ring rotates in brake cylinder groove. Slowly release press and ensure retainer ring securely holds cover in place.
2. If not accomplished during ‘Winch Assembly’ steps, install bracket (136) to inside of motor end upright (2) and secure in place using capscrews (137) and (142). Torque capscrews to 35 ft lbs (48 Nm).
 3. Assemble roller (146) in plunger (144) and secure using dowel pin (145). Heavily coat plunger assembly with “LubriPlate” MO-LITH No. 2 or equivalent lubricant. Install spring (143) and plunger assembly in brake bracket (136). Align groove in plunger towards hole in motor end (2) upright.
 4. Align cylinder rod roller surface to groove in plunger. Turn cylinder (151) clockwise until snug. Adjust cylinder (151) such that air hose connection port is horizontal and towards the motor.

Conduct the following when winch is assembled, but prior to mounting to foundation. The motor end of winch should be raised enough to allow access to brake components located on the inside surface of inboard (motor end) upright (2).

5. Place spacer (135) between upper brake band flange and bracket. Attach band assembly (134) to bracket (136) using three capscrews (131), spacers (132) and spacer tubes (133). Torque capscrews to 35 ft lbs (48 Nm).
6. Install pivot bar (148) and capscrew (149) through lower flange of brake band assembly (134). At lowest point of threads, place a bead of Loctite® 680 and install jam nut (147) fully. Jam nut threads must become coated with sealant. Install second jam nut (147) to approximate middle of thread length. Thread capscrew (149) into bottom of plunger (144) a minimum of five thread lengths. Lock in place, against plunger, using jam nut (147). Adjust brake as described in ‘Drum Band Brake Adjustment’ section.

Adjusting Automatic Drum Band Brake

Optional Feature. Refer to Dwg. MHP1730 on page 52.

CAUTION

• **This adjustment is done after a rebuild. It is only a rough adjustment intended to remove major slack prior to adjusting with a load.**

This procedure can be done at a work bench using a 50 psig air supply applied to the brake cylinder. After completion of this procedure the brake must further be adjusted using the recommended air supply and a test load.

1. Insert a length of 3/8 inch NC threaded rod, fully into the cylinder rod (138). With brake band slack and no air supplied to brake, push end of threaded rod to position plunger all the way inside brake bracket (136). Place a nut on threaded rod, and locate nut until it is just touching cover (156). Apply air to brake. Threaded rod should move out from cylinder approximately 1 inch (25 mm).
2. Tighten capscrew (149) in plunger (144) to remove slack from band brake. Release air pressure. Nut should move closer to end cover (155) and stop.

3. Repeat step 1 until nut stops at approximately 9/16 inch (14 mm) from cover (155).
4. Refer to further adjusting in 'Automatic Drum Brake Adjustment'.

Freespool Assembly

Optional feature. Refer to Dwg. MHP1828 on page 66.

1. Apply Loctite® 609 to dowel pin (516) and install into end of shifter (515).
2. For steps 3 through 5, it is recommended that shifter (515) be secured using a vise. Care should be taken to ensure shifter is not damaged by the vise. Use leather or copper-covered vise jaws to prevent scoring. Position shifter in vise with dowel pin placed at bottom.
3. Lubricate spring (509) with grease and place into shifter. Locate latch (511) on end of spring.
4. Slide detent plate (514) onto shifter and seat against raised edge of shifter.
5. Place base of handle (512) into shifter slot. Using handle, push against latch to compress spring until hole in handle base and hole in shifter slot are aligned. Press dowel pin (508) in hole on one side of shifter slot, through handle and into hole in other side of shifter slot. Center dowel pin. Remove assembly from vise.
6. With output shaft (32) installed in winch upright, attach shaft support (503) to output shaft with capscrews (504). Tighten capscrews.
7. Lightly lubricate shaft support mating surface.
8. Lubricate 'O' ring (501) and install into groove in housing (502) shifter port.
9. Fully slide housing over lubricated mating surface of shaft support.
10. Install shifter assembly into shifter port on housing with handle pointing down. It is necessary to align dowel pin to shaft support groove. To do this slide housing with shifter assembly in and out on shifter shaft as necessary, while pressing on shifter assembly until dowel pin slips into support shaft groove.
11. Install capscrews (513) in detent plate (514) to secure to housing. Tighten capscrews.
12. To locate assembly to correct position, with handle pointing down and on the right hand side of housing as viewed from the end opposite the motor, conduct the following:
 - a. Rotate housing to align capscrew holes in upright (3). Position handle on right and pointing down.

NOTICE

• **During this step shaft support (503) should remain in position with output shaft (32) fully engaged in upright (3).**

- b. Install capscrews (505) and secure housing to upright. Torque capscrews to 18 ft lbs (24 Nm).
13. Visually verify free spool operation. Refer to 'Free Spool' in the "OPERATION" section for instructions. During operation observe the shaft support (503) to determine movement.
 - a. When in 'Free Spool Position' the shaft support should shift out, towards the end of the housing, as handle is rotated.

- b. When in 'Non-Free Spool Position' the shaft support should shift in, towards the upright. The drum may require slight rotation to correctly align the output shaft to the upright during shifting.
 - c. There should be no indication of sticking or binding during free spool operation.

14. Place gasket (34) and cover (35) onto housing. Align holes and install capscrews (36) and washers (37). Torque capscrews to 12-15 ft lbs (16-20 Nm).

Drum Guard Assembly

Optional feature. Refer to Dwg. MHP1110 on page 65.

1. Place drum guard (537) on rear sideframe (12) with longer inside tab located under sideframe edge and smaller outside tabs located on top of sideframe edge.
2. Place washers (533) on brackets (531) or bracket shaft (536). Install washers in quantities required to remove any 'play' or gap between drum guard and brackets.
3. Align brackets (531) or (535) on mounting holes in uprights (3) and (2). Secure in place with capscrews (532).
4. Install washer (42) and lifting eye (41). Torque to 225 ft lbs (306 Nm).

Testing

Operational Test

Prior to initial use, all new or repaired winches shall be tested to ensure proper operation.

1. Check oil level in reduction gear assembly and disc brake is correct. Top off levels as required before operation as described in "LUBRICATION" section.
2. To initially 'break in' new or overhauled motors, operate winch without load, in both directions, for 15 minutes at 100-200 RPM.
3. Check operation of brakes. Adjust if necessary as described in "MAINTENANCE" section.
4. Check foundation mounting fasteners are secure.
5. If equipped, install drum guard.

Load Test

Prior to initial use, all new or extensively repaired winches shall be load tested by or under the direction of a person trained in safety and operation of this winch and a written report furnished confirming winch rating. Test loads shall not be less than **100%** of rated line pull at mid drum and should not exceed **125%** of rated line pull at mid drum.

To test winch at **125%** of rated load at mid drum apply the following load:

Winch 125% Test Load **5,000 lb. (2,268 kg)**

NOTICE

• **Testing to more than 125% of rated line pull may be required to comply with standards and regulations set forth in areas outside the USA.**

WINCH CROSS SECTION DRAWING

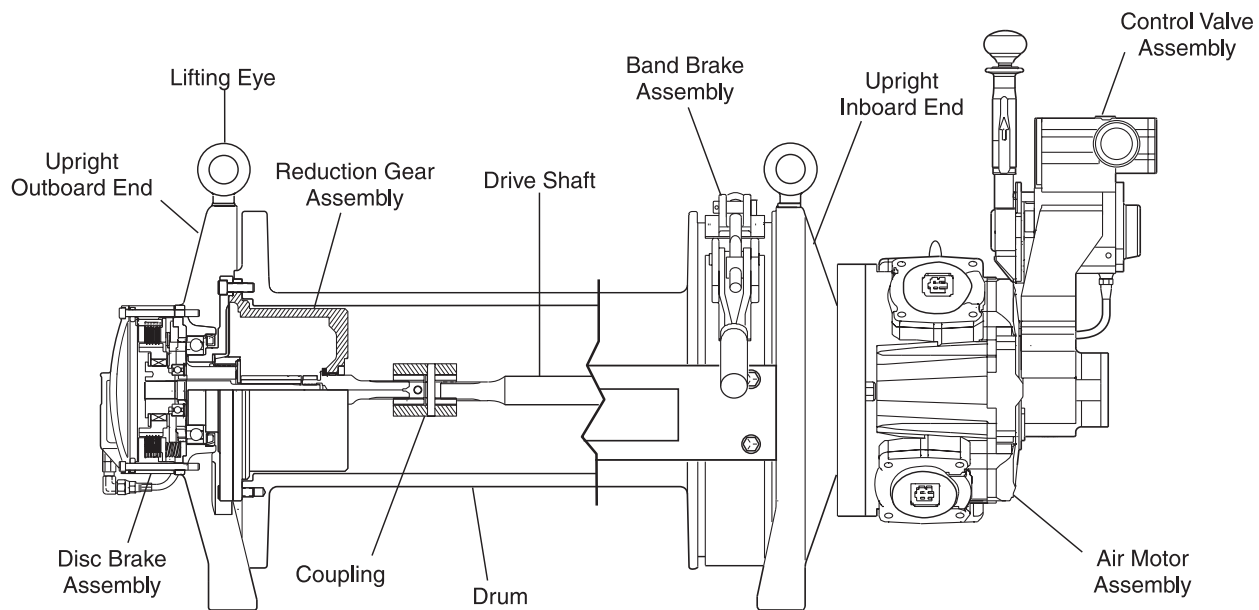

(Dwg. MHP1826)

PARTS DRAWINGS AND PARTS LISTS TABLE OF CONTENTS

Description	Page
Winch Assembly Parts Drawing (MHP1565)	42
Winch Assembly Parts List	43
FA2B Winch Motor Assembly Parts Drawing (MHP1796)	44
FA2B Winch Motor Assembly Parts List	45
HU40A Winch Motor Assembly Parts Drawing (MHP1827)	46
HU40A Winch Motor Assembly Parts List	47
AMP94A Winch Motor Assembly Parts Drawing (MHP1845)	48
AMP94A Winch Motor Assembly Parts List	49
Disc Brake Assembly Parts Drawing (MHP1579)	50
Disc Brake Assembly Parts List	51
Automatic Drum Band Brake Assembly Drawing (MHP1730) and Parts List	52
Manual Drum Band Brake Assembly Drawing (MHP1721) and Parts List	53
FA2B Winch Control Valve Assembly Parts Drawing (MHP1794)	54
FA2B Winch Control Valve Assembly Parts List	55
Remote Pilot Air Control Assembly Parts Drawing (MHP1846)	56
Remote Pilot Air Control Assembly Parts List	57
Control Air Valve Assembly Drawing (MHP1858) and Parts List	58
Remote Full Flow Valve Assembly Drawing (MHP1841) and Parts List	59
HU40A Winch Control Valve Assembly Parts Drawing (MHP1720)	60
HU40A Winch Control Valve Assembly Parts List	61
AMP94A Winch Valve Chest Assembly Drawing (MHP1844) and Parts List	62
FA2B Winch Motor Muffler Assembly Drawing (MHP1855) and Parts List	63
Open Frame (Face) Assembly Drawing (MHP1374) and Parts List	64
Drum Guard Assembly Drawing (MHP1110) and Parts List	65
Free Spool Assembly Drawing (MHP1828) and Parts List	66
Accessories	67
Kits Parts List	67
General Options	67
Electric Motor Specifications	68
Hydraulic Motor Specifications	68
Winch Label/Tag Location Drawing (MHP1825) and Parts List	69
Parts Ordering Information	70
Publication Reference	70
Warranty	71

WINCH ASSEMBLY PARTS DRAWING

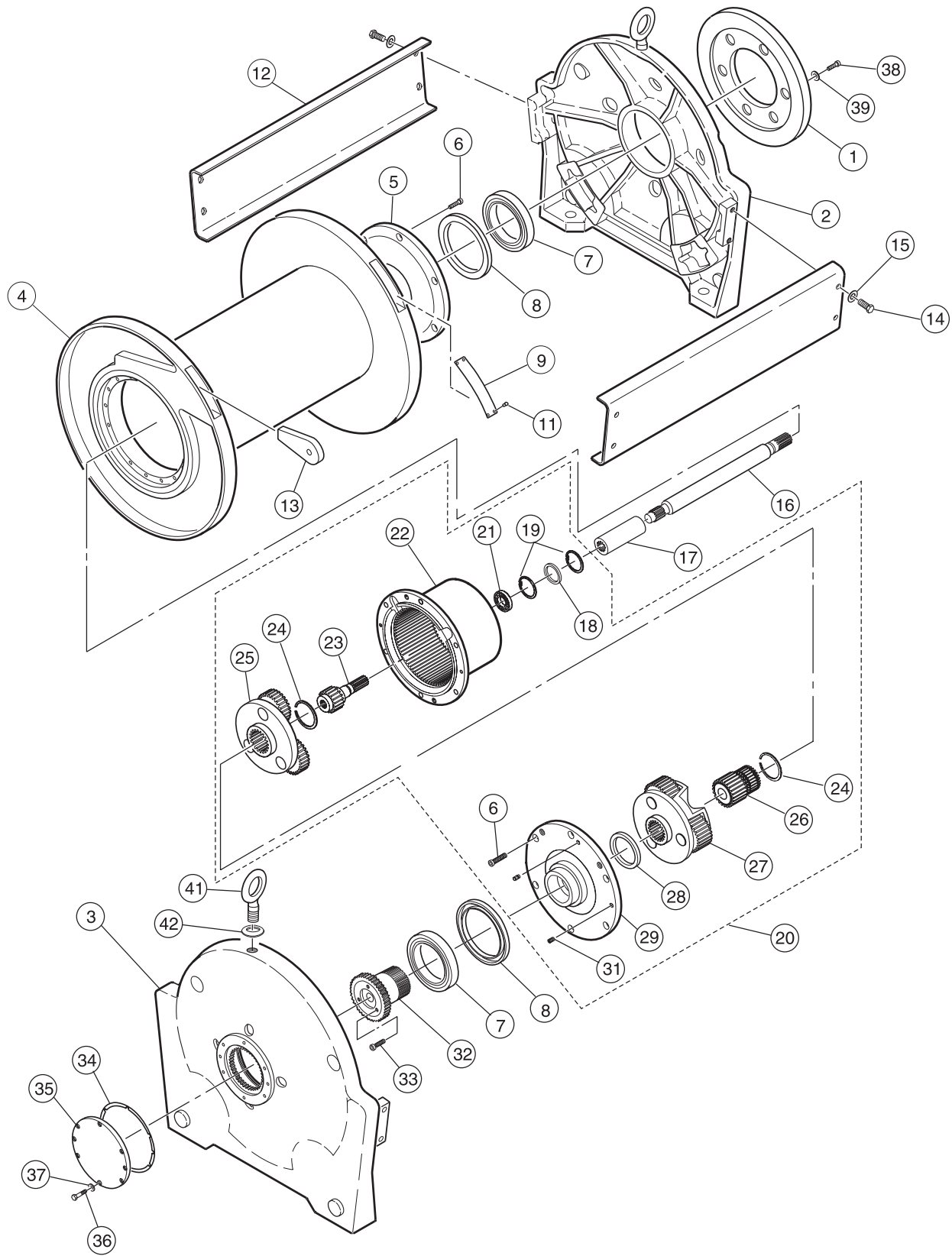

(Dwg. MHP1565)

WINCH ASSEMBLY PARTS LIST

ITEM NO.	DESCRIPTION OF PART	QTY TOTAL	PART NUMBER	ITEM NO.	DESCRIPTION OF PART	QTY TOTAL	PART NUMBER
1	Motor Adapter, FA2B	1	26640	13	Wire Rope Anchor (3/8 to 5/8 in. [10 to 16 mm] wire rope only)	1	25539
	Motor Adapter, HU40A		27124				
	Motor Adapter, AMP94A		contact factory				
2	Upright, Motor End † without drum brake	1	24893	17	Coupling	1	25482
	Upright, Motor End † with drum brake		24893-1	18	Seal	1	C120060
				19	Retainer Ring	2	C080047
				20	Gearbox Assembly 39.6:1 ratio *	1	26866
3	Upright, Outboard End †	1	27146-1	21	Bearing	1	C010068
4	Drum	1		22	Reducer Housing *	1	26866
	Short with Band Brake †		25311	23	Sun Gear *	1	
	Short without Band Brake †		25106	24	Retainer Ring *	2	
	Medium with Band Brake †		contact factory	25	Planetary Gear Assembly *	1	
	Medium without Band Brake †		24916	26	Sun Gear *	1	
	Long with Band Brake †		25040	27	Planetary Gear Assembly *	1	
	Long without Band Brake †		25108	28	Thrust Bearing *	1	
	Extra long with Band Brake †		25751	29	Cover *	1	
	Extra long without Band Brake †		25748	31	Plug *	2	
5	Drum End	1	25071	32	Output Shaft †	1	24817
6	Capscrew	12	71306435	33	Capscrew	3	71266936
7	Bearing	2	71293633	34	Gasket	1	71262257
8	Seal	2	71293625	35	Cover	1	21732
9	Label, Cover Anchor Pocket	1	71297824	36	Capscrew	6	71266613
11	Drive Screw	4	50915	37	Washer	6	71303408
12	Sideframe	2		38	Capscrew	6	71347959
	Short Drum with Band Brake †		24901-6P	39	Washer	6	71304844
	Short Drum without Band Brake †		24901-1P	41	Eyebolt	2	71352868
	Medium Drum with Band Brake †		24901-4P	42	Washer	2	71352884
	Medium Drum without Band Brake †		24901-2P				
	Long Drum with Band Brake †		24901-3P				
	Long Drum without Band Brake †		24901-5P				
	Extra long Drum with Band Brake †		24901-8P				
	Extra long Drum without Band Brake †		24901-7P				

• Recommended spares for 1 winch, 2 years of normal service.

* Gearbox Assembly (item 20) includes items 6 and 18-31 sold only as a complete assembly.

† These parts also come in a cold weather version. For winches with a -C in the model code, adding CH to the end of these part numbers is required to retain winch certification. Example: Order Upright, Motor End (item 2) part number 24893-1 as part number 24893-1CH.

FA2B Drive Shaft				HU40A Drive Shaft			
16	Short Drum with Band Brake †	1	26939-5	16	Short Drum with Band Brake †	1	27126-5
	Short Drum without Band Brake †		26939-1		Short Drum without Band Brake †		27126-1
	Medium Drum with Band Brake †		26939-6		Medium Drum with Band Brake †		27126-6
	Medium Drum without Band Brake †		26939-2		Medium Drum without Band Brake †		27126-2
	Long Drum with Band Brake †		26939-7		Long Drum with Band Brake †		27126-7
	Long Drum without Band Brake †		26939-3		Long Drum without Band Brake †		27126-3
	Extra long Drum with Band Brake †		26939-8		Extra long Drum with Band Brake †		27126-8
	Extra long Drum without Band Brake †		26939-4		Extra long Drum w/out Band Brake †		27126-4

FA2B MOTOR ASSEMBLY PARTS DRAWING

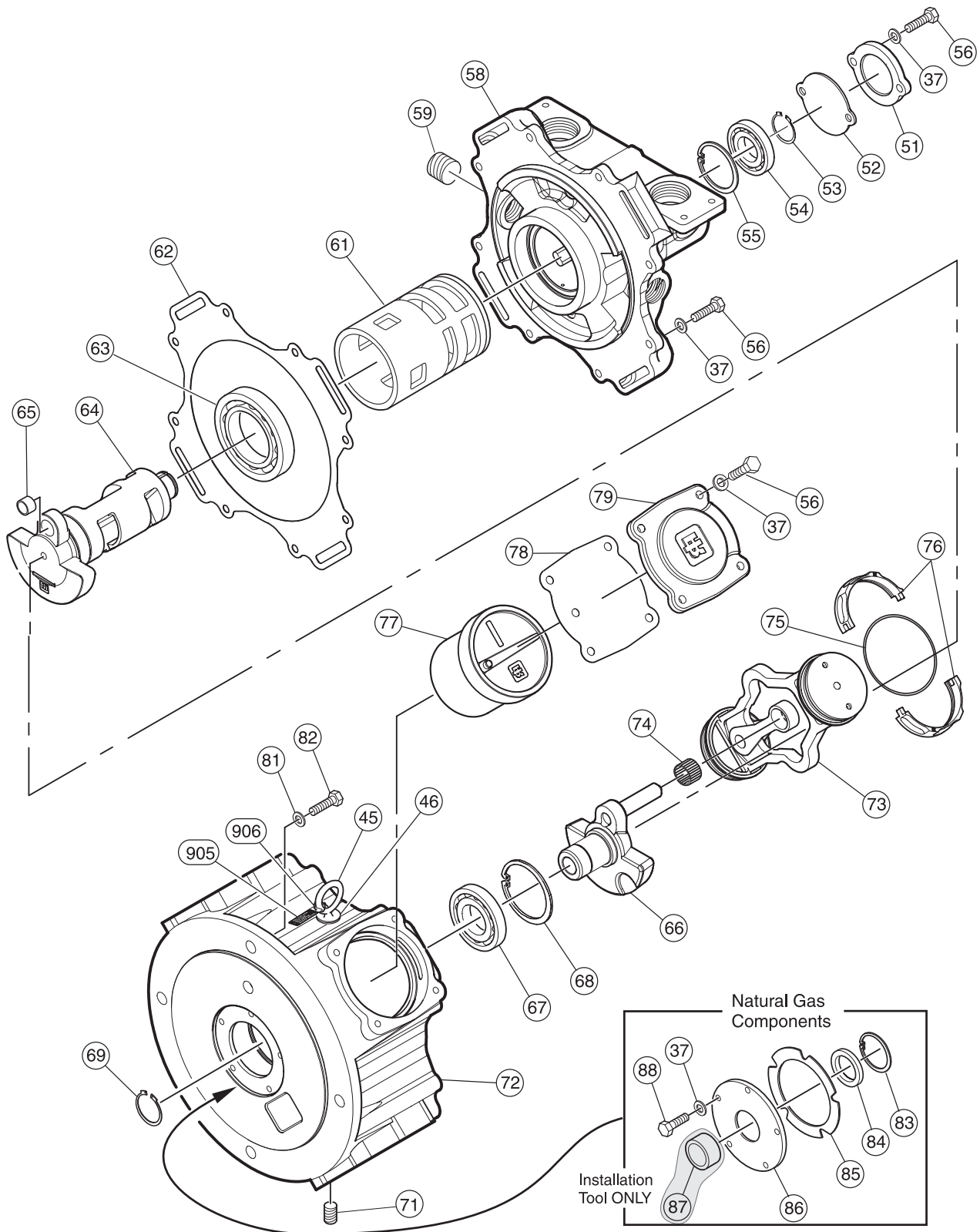

(Dwg. MHP1796)

FA2B MOTOR ASSEMBLY PARTS LIST

ITEM NO.	DESCRIPTION OF PART	QTY TOTAL	PART NUMBER	
			AIR	NATURAL GAS
37	Washer	26	71303408	
45	Eyebolt	1	71342109	
46	Washer	1	50182	
50	Motor Assembly (includes items 45, 46 and 51-79)	1	MP150	
51	Rotary Housing Cover	1	26660	
52	Gasket, Rotary Housing	1	26653	26653-1
53	Retainer Ring	1	71345458	
54	Bearing	1	53071	
55	Retainer Ring	1	71345441	
56	Capscrew	26	71348973	
58	Rotary Housing	1	26684	
59	Pipe Plug	1	52304	
61	Rotary Valve Bushing (includes items 52-55, 62 and 63)	1	27241	
62	Gasket, Manifold	1	26652	26652-1
63	Bearing	1	71342083	
64	Rotary Valve (includes item 65)	1	27174	
65	Bushing	1	71345466	
66	Crankshaft	1	26676	
67	Bearing	1	71348007	
68	Retainer Ring	1	52678	
69	Retainer Ring	1	51192	
71	Plug	1	54292	
72	Motor Housing	1	26732	
73	Piston Assembly (includes items 74, 75 (qty 2) and 76 (qty 4))	2	25726	
74	Piston Bearing	2	71287130	
75	'O' Ring (available only as kit, includes item 76)	1	27166	27194
76	Piston Rings (available only as kit, includes item 75)			
77	Cylinder	4	26662	
78	Gasket, Cylinder Cap	4	26651	26651-1
79	Cylinder Cap	4	26659	
81	Capscrew	4	71342067	
82	Washer	4	52914	
*	Label, Do Not Fill With Oil	1	71347314	
*	Label, Exhaust	1	71042196	
83	Retainer Ring	1	---	71348460
• 84	Seal	1	---	71348395
• 85	Gasket	1	---	26981
86	Plate	1	---	26975
87	Seal Installation Tool	1	---	27001
88	Capscrew	5	71351944	
905	Label, Do Not Lift	1	71355655	
906	Wire Tie	1	54235	

* Not shown on drawing. Refer to "WINCH LABEL/TAG LOCATION DRAWING AND PARTS LIST" on page 69.

KIT DESCRIPTION	PART NUMBER
Natural Gas Motor (only) Conversion Kit (includes items 37, 52, 62, 75, 76, 78 and 83-88)	26974
• Piston Ring Kit – Normal Operation (includes items 75 (qty 4) and 76 (qty 8) for 1 motor)	27166
Piston Ring Kit – Natural Gas Operation (includes items 75 (qty 4) and 76 (qty 8) for 1 motor)	27194
• Gasket Kit – Normal Operation (includes items 52, 62 and 78 (qty 4))	26679
Gasket Kit – Natural Gas Operation (includes items 52, 62 and 78 (qty 4))	27193
• Recommended spares for 1 winch, 2 years of normal service.	

HU40A WINCH MOTOR ASSEMBLY PARTS DRAWING

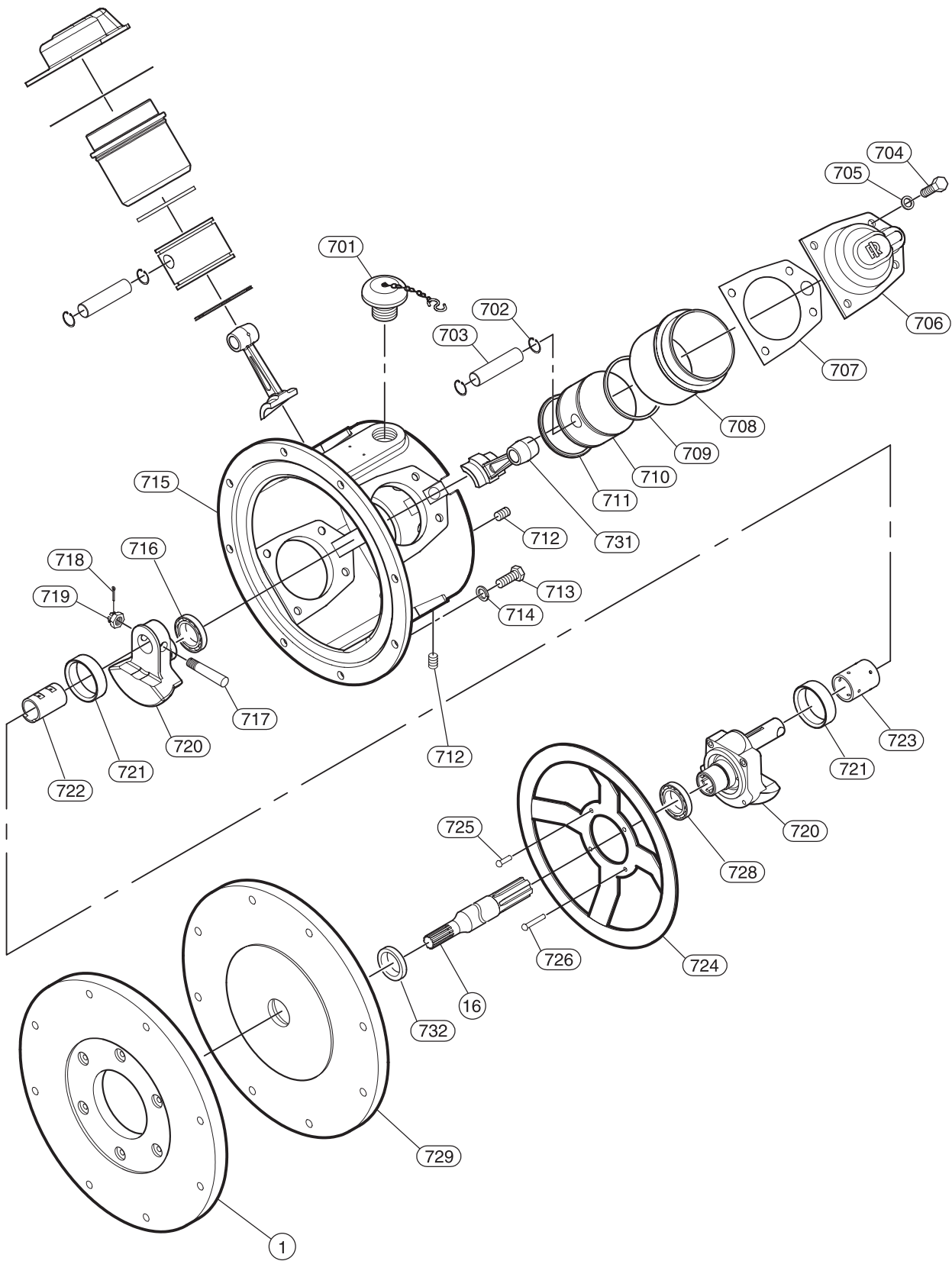

(Dwg. MHP1827)

HU40A WINCH MOTOR ASSEMBLY PARTS LIST

ITEM NO.	DESCRIPTION OF PART	QTY TOTAL	PART NUMBER
1	Adapter	1	27124
16	Drive Shaft	1	
	Short Drum with Band Brake †		27126-5
	Short Drum without Band Brake †		27126-1
	Medium Drum with Band Brake †		27126-6
	Medium Drum without Band Brake †		27126-2
	Long Drum with Band Brake †		27126-7
	Long Drum without Band Brake †		27126-3
	Extra long Drum with Band Brake †		27126-8
	Extra long Drum without Band Brake †	27126-4	
700	Motor Assembly (includes items 701-732 and Valve Chest Assembly (750) shown on page 60)	1	HU40-B501
701	Vent Cap Assembly	1	26604
702	Retainer Ring	8	902A45-632
703	Pin, Wrist	4	HU-514A
704	Capscrew	16	D10-354
705	Washer	16	HU-504
706	Head	4	HH5D-H505A
• 707	Gasket	4	HU-507
708	Sleeve	4	HH5D-L505A
709	Compression Ring †	1	HU-KRING
710	Piston Assembly (includes 1 each of items 702, 703, 709 and 711)	4	HU-A513B
711	Oil Ring †	1	HU-KRING
712	Plug	2	D02-402
713	Capscrew	10	215-148
714	Lockwasher	10	50181
715	Motor Housing	1	HU-501
716	Bearing	1	HU-518
717	Pin ††	1	HU-520
718	Pin, Cotter ††	1	53456
719	Nut ††	1	D02-394
720	Crankshaft Assembly - two pieces (includes items 717 through 720 and 724 through 726) ††	1	HU-516
721	Ring ††	2	HU-510
722	Bushing ††	1	HU-511
723	Sleeve ††	1	HU-519
724	Oil Splasher	1	HU-540
725	Rivet	2	231-712
726	Rivet	2	HU-541
728	Bearing	1	HUD-895
729	Baseplate	1	27125
731	Connecting Rod ††	4	HU-509
• 732	Seal	1	71352066

KIT DESCRIPTION	PART NUMBER
• † Ring Kit (includes items 709 and 711; quantity of 4 each)	HU-KRING
†† Crankshaft Assembly (includes items 717-723 and 731)	HU-A516

• Recommended spares for 1 winch, 2 years of normal service.

AMP94A WINCH MOTOR ASSEMBLY PARTS DRAWING

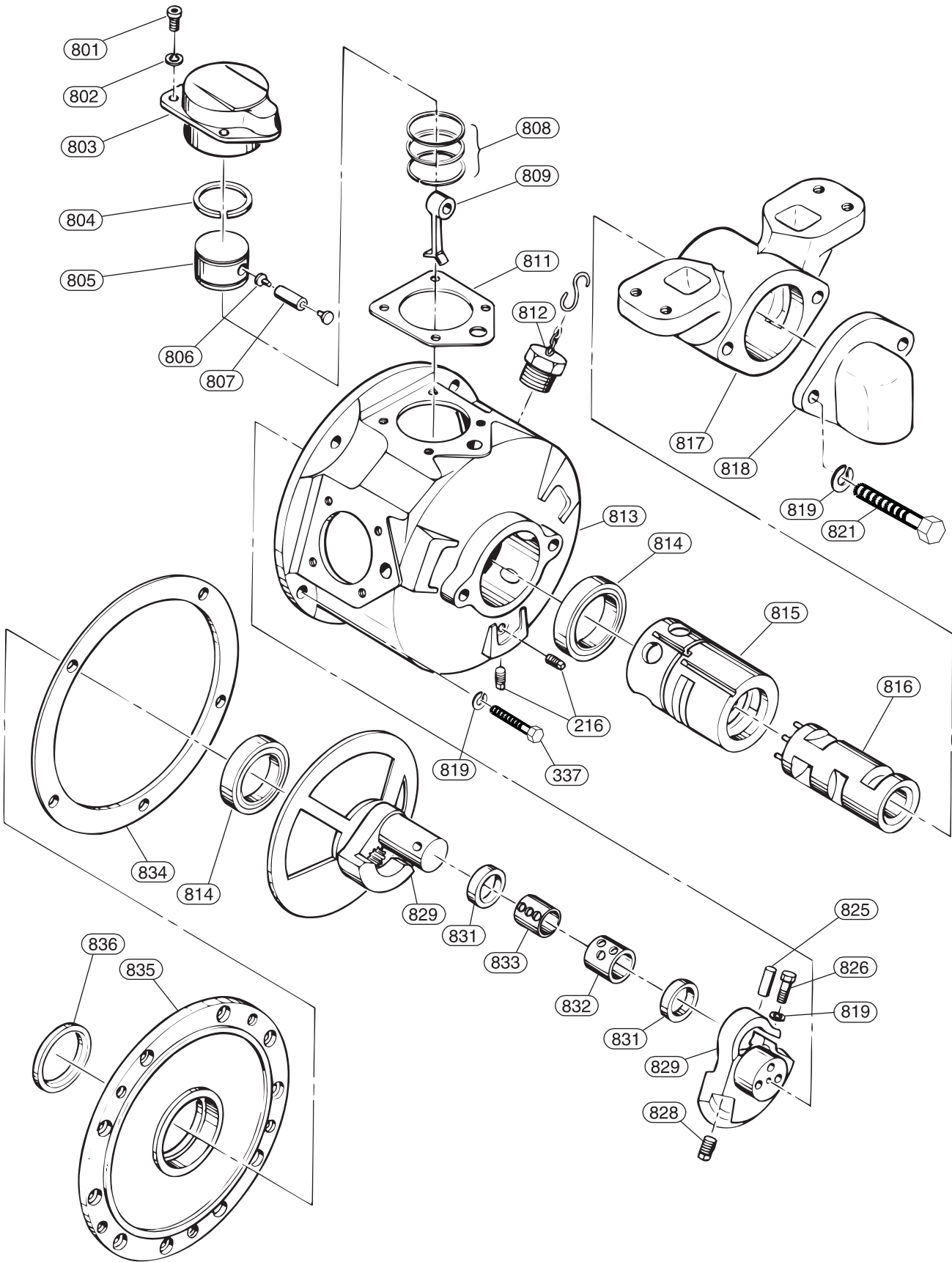

(Dwg. MHP1845)

AMP94A WINCH MOTOR ASSEMBLY PARTS LIST

ITEM NO.	DESCRIPTION OF PART	QTY TOTAL	PART NUMBER
216	Pipe Plug	2	50822
337	Capscrew	5	50829
800	Motor Assembly (incl's items 216, 337 and 801-836)	1	50259-1
801	Capscrew	20	50871
802	Washer, Copper	1 Set	94-027-20
803	Cylinder	5	94-024
804	Compression Ring	1	71032932
805	Piston Assembly (incl's 1 each of items 804, 807 and 808)	5	94-010A
806	Plug	10	Order Item 807
807	Wrist Pin Assembly (Incl's item 806)	5	94-0110-1A
808	Oil Ring	1	71032932
809	Connecting Rod	5	94-009
811	Gasket	1 Set	94-025-5
812	Vent Cap Assembly	1	94-018
813	Motor Housing	1	94-014
814	Bearing	2	50944
815	Rotary Bushing	1	10986
816	Rotary Valve	1	94-019
817	Valve Adapter	1	10987
818	Exhaust Cap	1	21-1
819	Lockwasher	7	50200
821	Capscrew	2	54711
825	Pin	1	94-004
826	Capscrew	1	51712
828	Setscrew	1	94-005
829	Crankshaft Assembly	1	94-001
831	Connecting Rod Ring	2	94-008
832	Bushing	1	94-006
833	Sleeve	1	94-007
834	Gasket	1	94-029
835	Adapter	1	10361
• 836	Oil Seal	1	52223

KIT DESCRIPTION	PART NUMBER
• Piston Service Kit (includes items 802 (qty=20), 804 (qty=5), 808 (qty=5), 811 (qty=5) and 834 (qty=1))	71032932

- Recommended spares for 1 winch, 2 years of normal service.

DISC BRAKE ASSEMBLY PARTS DRAWING

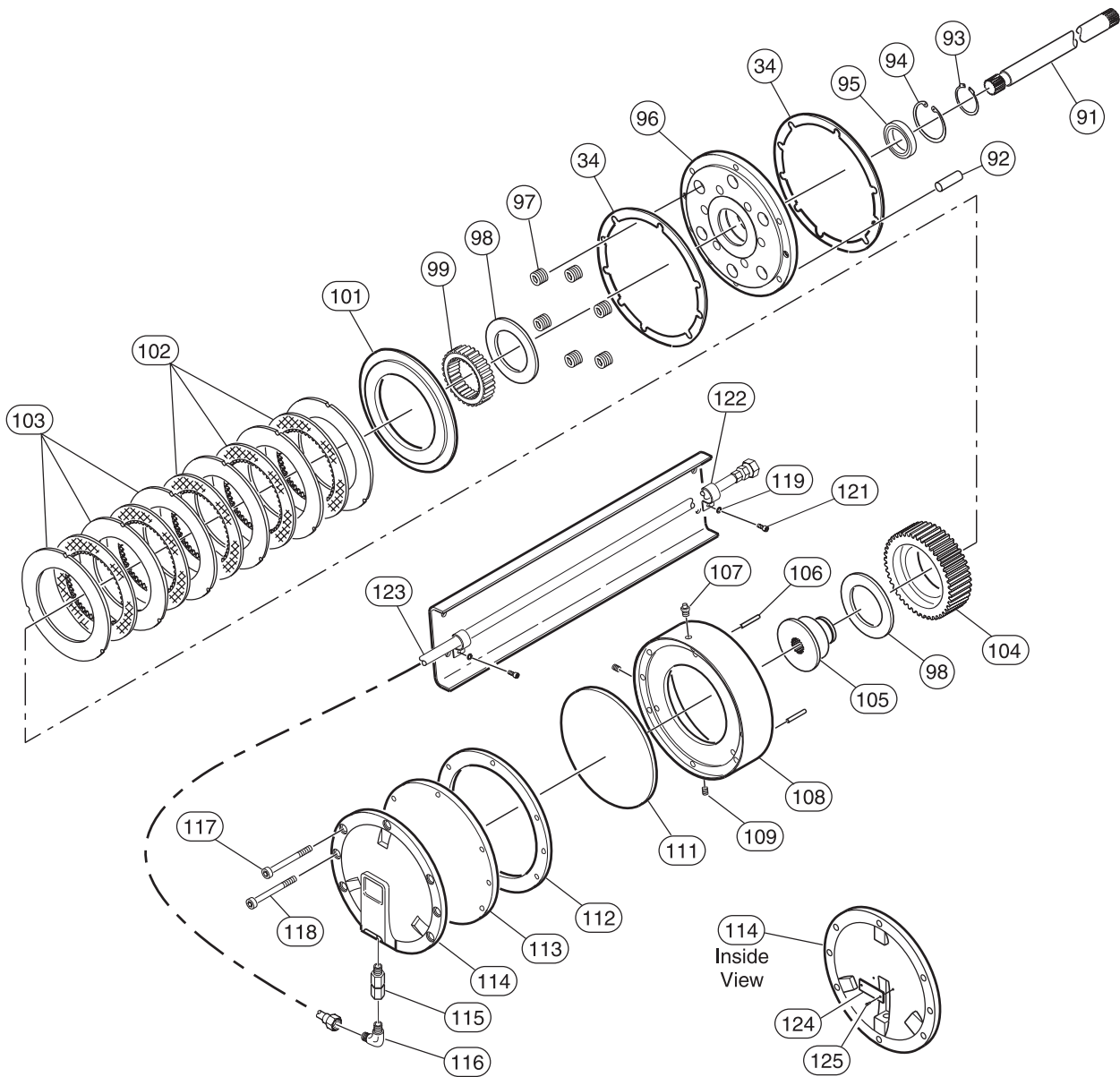

(Dwg. MHP1579)

DISC BRAKE ASSEMBLY PARTS LIST

ITEM NO.	DESCRIPTION OF PART	QTY TOTAL	PART NUMBER
34	Gasket	2	71262257
90	Disc Brake Assembly † (includes items 34, 92-114, 117 and 118)	1	26821
91	Brake Shaft †	1	25202
92	Dowel Pin	1	71126759
93	Retainer Ring	1	71053748
94	Retainer Ring	1	54375
95	Bearing	1	50449
96	Support Plate	1	26824
97	Spring	6	71053730
98	Spacer	2	19007
99	Sprag Clutch (1)	1	71044853
101	Pressure Plate	1	24137
102	Friction Plate (available only as kit)	1	27277
103	Separator Plate	6	22033
104	Outer Race (1) †	1	22032
105	Inner Race (1) †	1	24038
106	Dowel Pin	3	71126882
107	Breather	1	71271175
108	Housing	1	22026
109	Plug	2	71069009
111	Diaphragm Support	1	22027
112	Ring	1	22028
113	Diaphragm	1	22031
114	End Cover	1	26826
115	Valve Exhaust	1	71047898
116	Fitting, Elbow	1	24141
117	Capscrew	6	71264717
118	Capscrew	2	71354146
119	Washer	2	71046981
121	Capscrew	2	71146617
122	Clamp	2	71352389
123	Brake Hose, Short Drum (7 inch) without Band Brake	1	25403-47.5
	Brake Hose, Short Drum (7 inch) with Band Brake		25403-49
	Brake Hose, Medium Drum (13-1/2 inch) without Band Brake		25403-53.5
	Brake Hose, Medium Drum (13-1/2 inch) with Band Brake		25403-56
	Brake Hose, Long Drum (20 inch) without Band Brake		25403-60
	Brake Hose, Long Drum (20 inch) with Band Brake		25403-62.5
	Brake Hose, Extra Long Drum (24 inch) without Band Brake		25403-64
	Brake Hose, Extra Long Drum (24 inch) with Band Brake		25403-66.5
124	Brake Disc Configuration Label	1	71349492
125	Rivet	2	71028849

(1) Replace Sprag Clutch (item 99), Outer Race (item 104) and Inner Race (item 105) as a set.

† These parts also come in a cold weather version. For winches with a -C in the model code, adding CH to the end of these part numbers is required to retain winch certification. Example: Order Brake Shaft (item 91) part number 25202 as part number 25202CH.

KIT DESCRIPTION	PART NUMBER
• Disc Brake Service Kit (includes items 34, 102 (qty 5) and 113)	27277
Natural Gas Conversion Kit	27301

• Recommended spares for 1 winch, 2 years of normal service.

AUTOMATIC DRUM BAND BRAKE ASSEMBLY DRAWING AND PARTS LIST

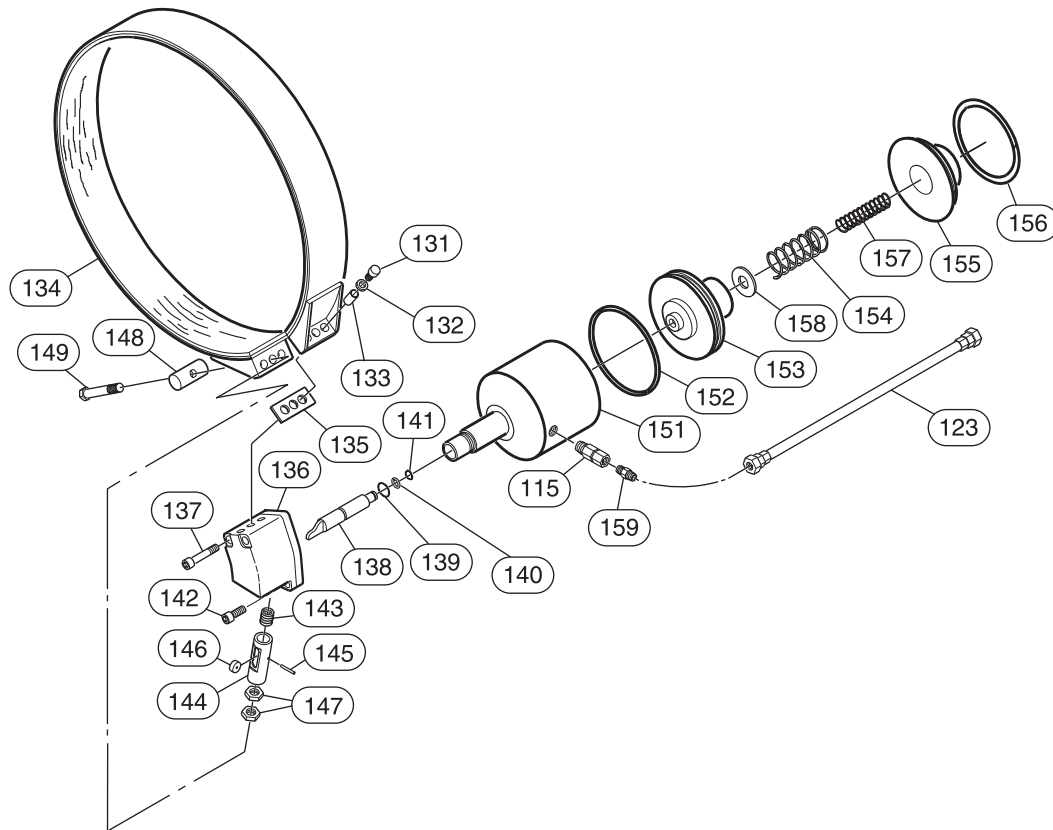

(Dwg. MHP1730)

ITEM NO.	DESCRIPTION OF PART	QTY TOTAL	PART NUMBER	ITEM NO.	DESCRIPTION OF PART	QTY TOTAL	PART NUMBER
115	Valve, Exhaust	1	71047898	144	Plunger †	1	23886
123	Hose Assembly	1	24403-39	145	Pin, Dowel	1	71144968
130	Brake Assembly (1)	1	25155	146	Roller †	1	23883
131	Capscrew	3	71264808	147	Jam Nut	2	71267413
132	Spacer	3	21899	148	Pivot Bar	1	23755
133	Spacer Tube	3	21891	149	Capscrew	1	71326805
• 134	Band Assembly †	1	25144	151	Cylinder	1	26138
135	Spacer	1	23029	• 152	'O' Ring	1	52536
136	Brake Bracket †	1	22984	153	Piston	1	25534
137	Capscrew	2	71298921	154	Spring	1	71299721
138	Cylinder Rod	1	23885	155	Cover	1	25392
• 139	'O' Ring	1	71350227	156	Retainer Ring	1	71126668
• 140	'O' Ring	1	52662	157	Spring	1	71299713
141	Retainer Ring	1	54136	158	Washer	1	71145080
142	Capscrew	2	71298939	159	Fitting, Nipple	1	52092
143	Spring	1	71126643				

• Recommended spares for 1 winch, 2 years of normal service.

(1) Brake Assembly includes items 131-158.

† These parts also come in a cold weather version. For winches with a -C in the model code, adding CH to the end of these part numbers is required to retain winch certification. Example: Order Brake, Bracket (item 136) part number 22984 as part number 22984CH.

MANUAL DRUM BRAKE ASSEMBLY DRAWING AND PARTS LIST

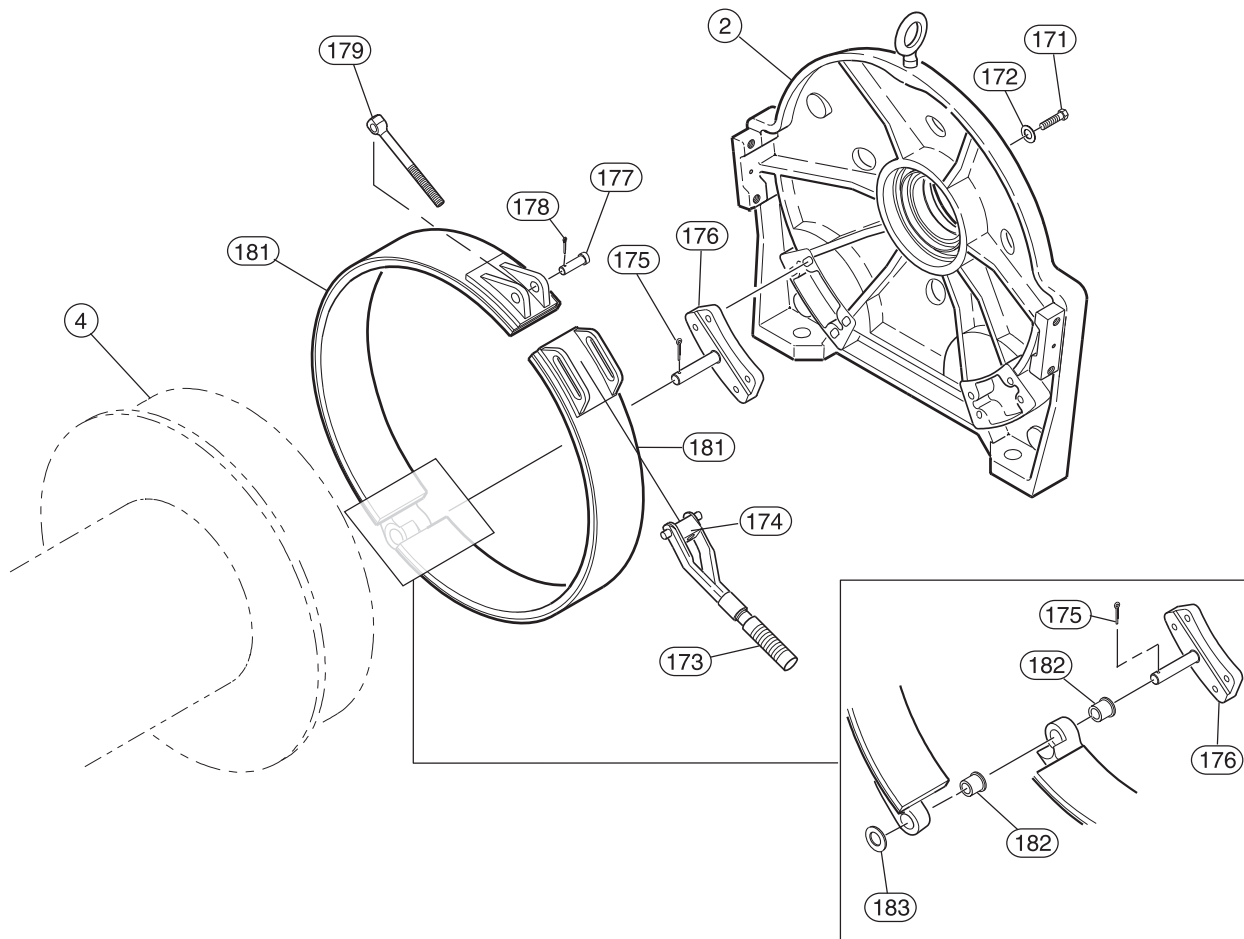

(Dwg. MHP1721)

ITEM NO.	DESCRIPTION OF PART	QTY TOTAL	PART NUMBER	ITEM NO.	DESCRIPTION OF PART	QTY TOTAL	PART NUMBER
170	Manual Drum Brake Assembly (includes item 171-183)	1	26360	176	Adapter Pin †	1	26350
2	Upright, Motor End	1	24893-1	177	Pin †		4303-S
4	Drum (Refer to page 43)			178	Cotter Pin	1	51937
171	Capscrew	4	71334429	179	Brake Link Stud †	1	2448
172	Washer	4	71334411	• 181	Brake Band Assembly (includes both brake bands and item 182, Bushing) †	1	26320
173	Handle, Brake (includes 174) †	1	2329	182	Bushing	2	71334403
174	Pivot Nut †	1	2445	183	Washer	1	71334379
175	Cotter Pin	1	50965				

† These parts also come in a cold weather version. For winches with a -C in the model code, adding CH to the end of these part numbers is required to retain winch certification. Example: Order Handle, Brake (item 173) part number 2329 as part number 2329CH.

KIT DESCRIPTION	PART NUMBER
• Brake Lining Kit (includes brake lining and rivets to reline both brake band sections and bushing (qty 2), item 182)	26804

• Recommended spares for 1 winch, 2 years of normal service.

FA2B CONTROL VALVE ASSEMBLY PARTS DRAWING

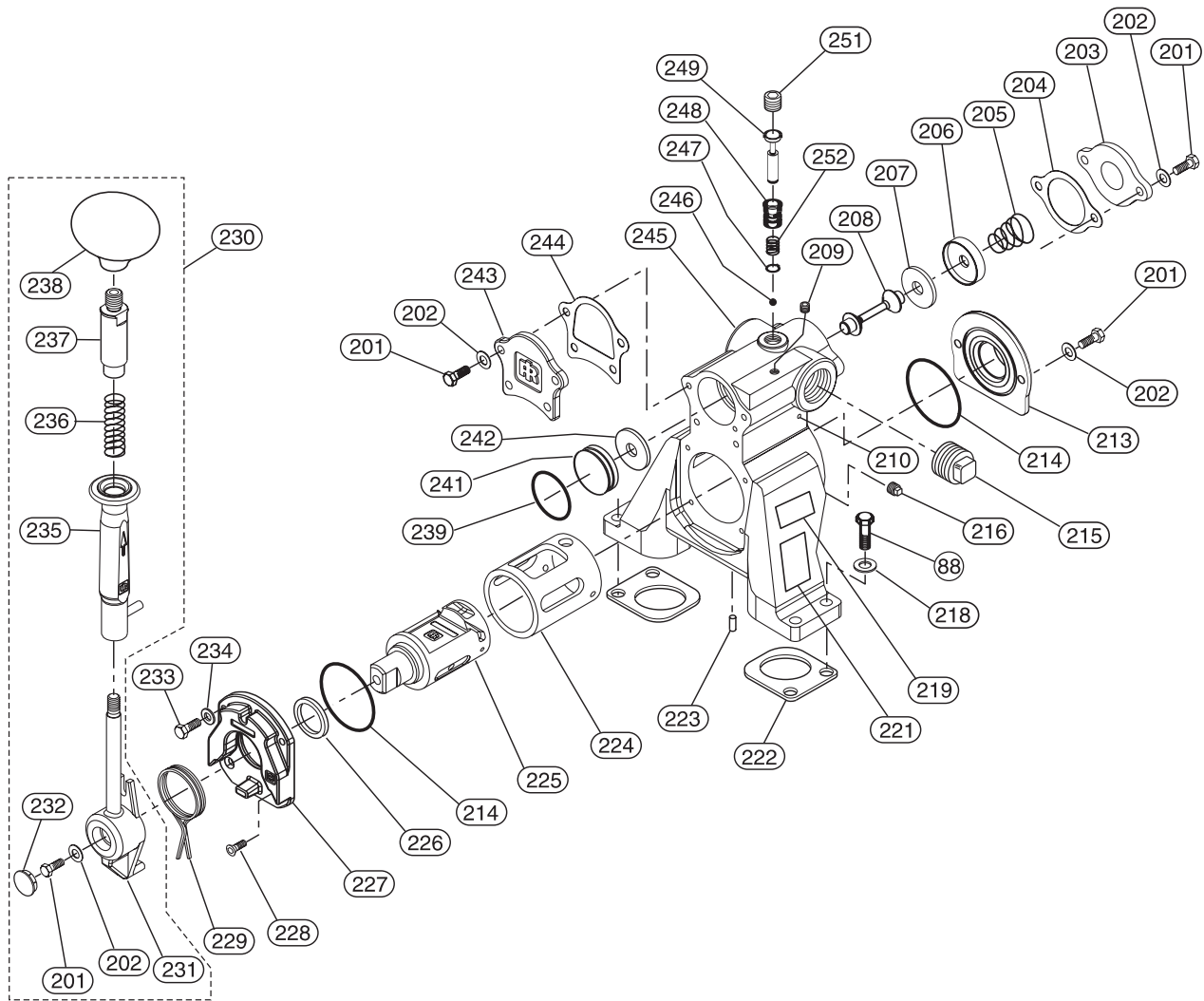

(Dwg. MHP1794)

FA2B CONTROL VALVE ASSEMBLY PARTS LIST

ITEM NO.	DESCRIPTION OF PART	QTY TOTAL	PART NUMBER	ITEM NO.	DESCRIPTION OF PART	QTY TOTAL	PART NUMBER
88	Capscrew	4	71351944	227	Seal Bracket	1	26962
200	Control Valve Assembly	1	K5C	228	Capscrew	2	71347207
201	Capscrew	9	71342034	229	Spring	1	26966
202	Washer	9	71303408	230	Handle Assembly (includes 201-202, 231-232, 235-238)	1	27239
203	Cover, Poppet	1	26997				
204	Gasket, Poppet – Air	1	27064	231	Valve Handle	1	26948
	Gasket, Poppet – Natural Gas		27064-1	232	Plug	1	71348965
205	Spring, Poppet	1	71351068	233	Capscrew	2	71348338
206	Cap, Poppet	1	26989	234	Washer	2	71271985
207	Seal, Poppet – Air	1	26991	235	Handle, Slide	1	26950
	Seal, Poppet – Natural Gas		26991-1	236	Spring	1	71348346
208	Shaft, Poppet	1	26990	237	Handle Post	1	26951
209	Plug, Air	1	24292	238	Ball	1	71348353
	Plug, Natural Gas		54658	239	'O' Ring, Air	1	71355796
210	Plug	2	71352751		'O' Ring, Natural Gas		
213	Exhaust Flange	1	26691	241	Piston	1	26996
214	'O' Ring, Air	2	51651	242	Seal, Piston – Air	1	26995
	'O' Ring, Natural Gas		71342547		Seal, Piston – Natural Gas		26995-1
215	Plug, Air	1	71263297	243	Cover, Piston	1	26998
	Plug, Natural Gas		E5UD-947	244	Gasket, Cover – Air	1	26999
216	Plug, Air	1	54675		Gasket, Cover – Natural Gas		
	Plug, Natural Gas		50822	245	Valve Housing	1	26964
218	Washer	4	54843	246	Ball	1	71127575
219	Label, Throttle Direction	1	71352777	247	Retainer Ring	1	71351092
221	Label, Warning-Natural Gas Vapors	1	71352769	248	Seat, Pilot	1	26992
222	Gasket, Air	2	27115	249	Pilot Rod	1	26970
	Gasket, Natural Gas		27115-1		251	Plug, Air	1
223	Pin	1	71146674	Plug, Natural Gas			
224	Bushing	1	26686	252	Spring, Pilot Rod	1	71351076
225	Reverse Valve	1	26969				
226	Seal, Air	Not Used					
	Seal, Natural Gas	1	71342554				

KIT DESCRIPTION	PART NUMBER
• Control Valve Service Kit – Air (includes items 204, 207, 214, 239, 242 and 244)	27240
Control Valve Service Kit – Natural Gas * (includes items 204, 207, 214, 222, 224, 226, 239, 242, 244, 247 and 249) * kit also converts air operated control valve to natural gas operated control valve	27240-1

- Recommended spares for 1 winch, 2 years of normal service.

REMOTE PILOT AIR CONTROL ASSEMBLY PARTS DRAWING

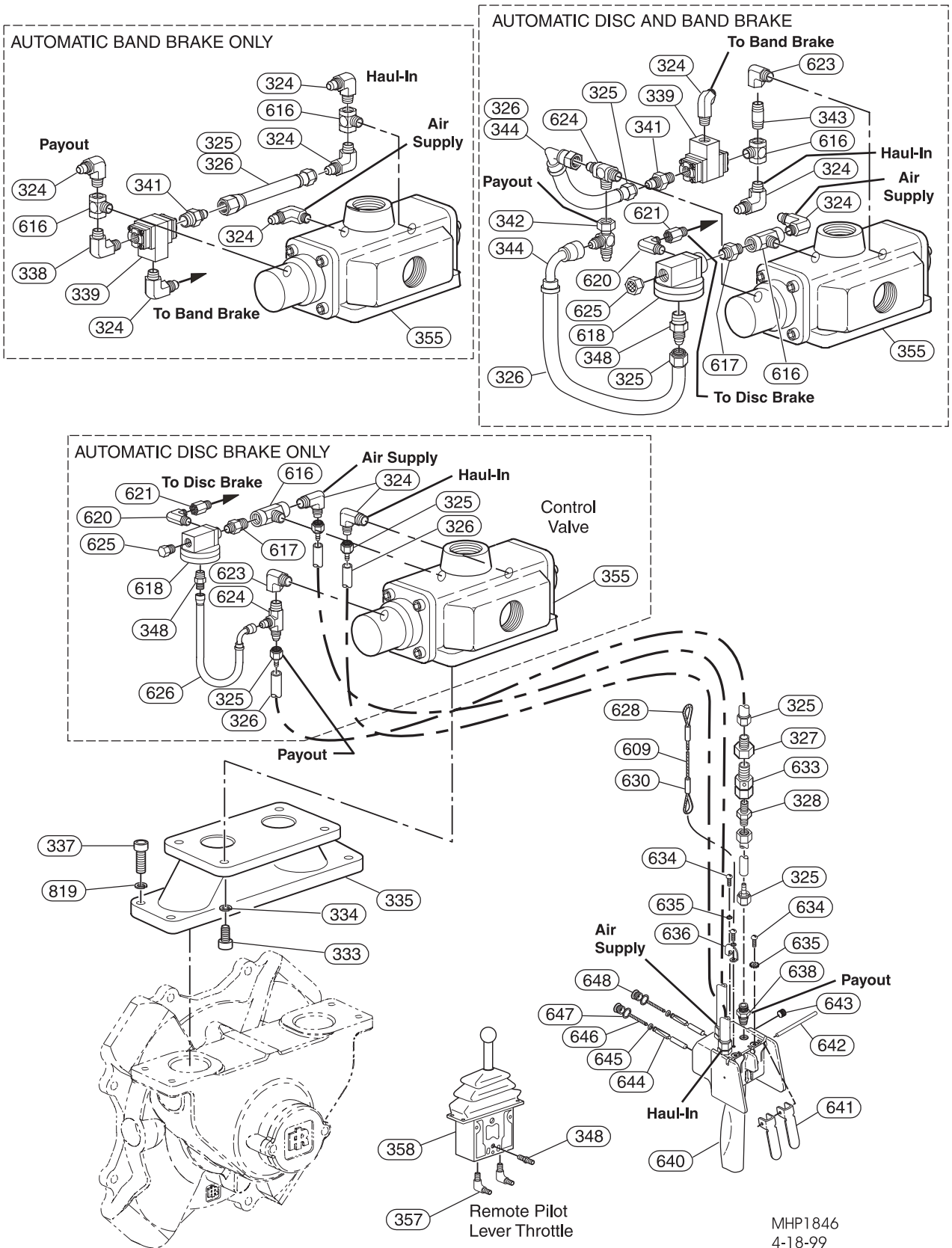

(Dwg. MHP1846)

REMOTE PILOT AIR CONTROL ASSEMBLY PARTS LIST

ITEM NO.	DESCRIPTION OF PART	QTY TOTAL	PART NUMBER
324	Fitting, Elbow *	3 (5)	52182
325	Fitting, Hose End – Disc Brake only	8	51029
	Fitting, Hose End – Disc and Automatic Drum Band Brake	10	
326	Hose, Bulk	As required	50923-XX
327	Fitting, Connector	2	71048284
328	Fitting, Connector	2	71048268
333	Capscrew	4	54681
334	Lockwasher	4	50893
335	Manifold	1	13881
337	Capscrew	4	50829
338	Fitting, Elbow	1	54273
339	Shuttle Valve	1	50277
341	Fitting, Connector	1	51814
342	Fitting, Tee	1	71067789
343	Fitting, Nipple	1	51034
344	Fitting, Elbow	2	52179
348	Fitting, Connector	2	52092
355	Valve Assembly	1	26170
357	Fitting, Elbow	2	51281
358	Pilot Lever Throttle Assembly	1	71069561
609	Strain Relief Cable †	Specify length in feet	BWR3A
616	Fitting, Tee *	1 (2)	54977
617	Fitting, Connector	1	54679
618	Valve	1	54672
620	Fitting, Elbow	1	71063473
621	Fitting, Connector	1	71110894
623	Fitting, Elbow	1	71034714
624	Fitting, Tee *	1 (2)	52181
625	Breather	1	51559
626	Hose Assembly	1	17073-6
628	Clamping Thimble †	2	MLK-602
630	Clamping Sleeve †	2	MLK-521
633	Quick Exhaust Valve Assembly (includes items 325 (qty 2), 327 (qty 1) and 328 (qty 1))	††	20417
634	Screw	4	HRE20A-68
635	Lockwasher (10 per pack)	1 pack	H54U-352-10
636	Strain Relief Support	1	MLK-450
638	Fitting, Nipple	3	MLK-165
640	Pendant Assembly (includes items 634–638 and 641–648)	1	MLK-269C
641	Throttle Lever	2	MLK-273
642	Throttle Lever Pin	1	DLC-120A
643	Plug	1	502-95
644	Pendant Throttle Valve	2	MLK-K264B
645	Valve Seal	2	R000BR1C-283
646	Valve Spring	2	MLK-51A
647	Valve Cap Gasket	2	MLK-504
648	Valve Cap	2	MLK-K266A
819	Lockwasher	4	50200
Not Shown	Hose Tie (3 for standard hose; 2 additional each 5 feet of hose)		HRE20A-283

* Numbers in parentheses are maximum quantities possible depending upon the specific configuration of the valve.

† Strain Relief Assembly, Part Number MLK-LWR3A consists of items 609, 628 and 630. A crimping tool (Nicropress® Tool with groove size G) required to install the clamping sleeves (630).

†† Quantity of 2 Quick Exhaust Valve Assemblies required when hose length exceeds 20 feet (6 metres); quantity of 4 required when hose length exceeds 50 ft (16 metres).

XX Order in even feet increments; i.e., 50923-02 = 2 feet (0.6 metres). Metres listed for reference only.

CONTROL AIR VALVE ASSEMBLY DRAWING AND PARTS LIST

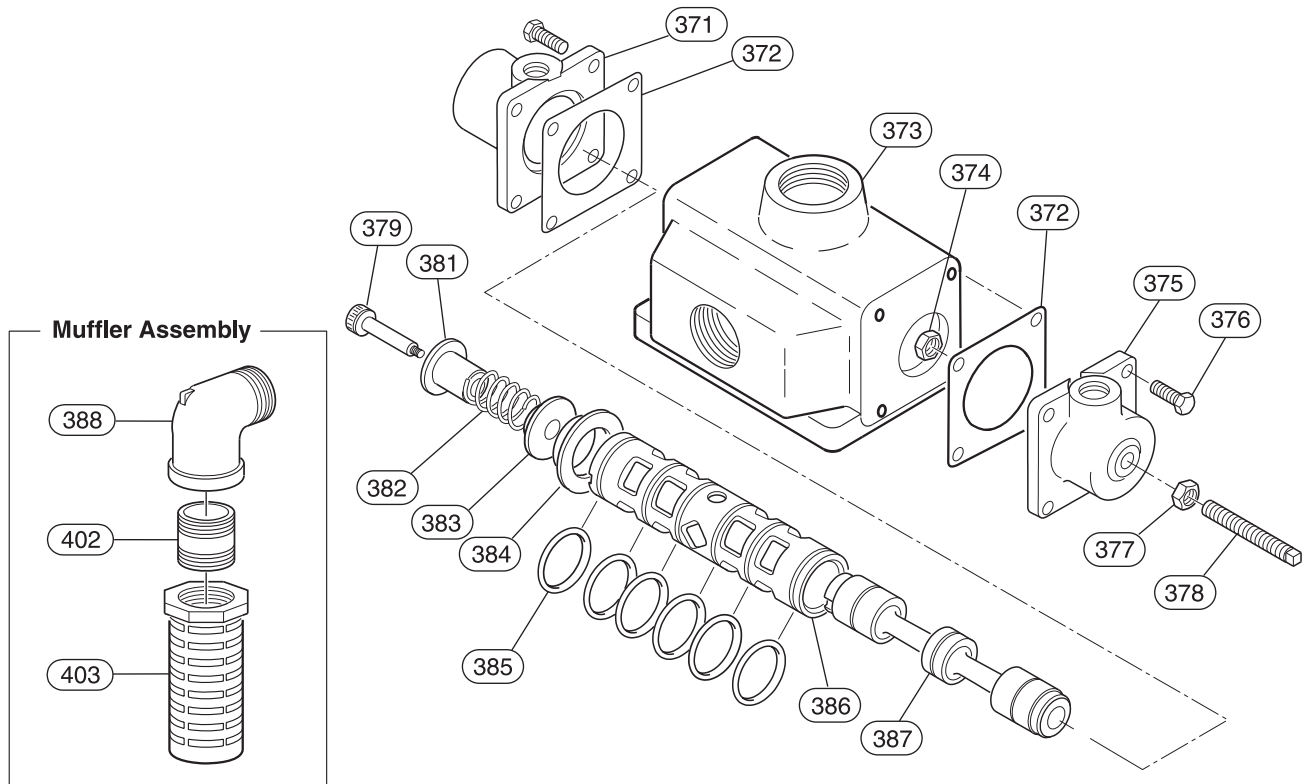

(Dwg. MHP1858)

ITEM NO.	DESCRIPTION OF PART	QTY TOTAL	PART NUMBER	ITEM NO.	DESCRIPTION OF PART	QTY TOTAL	PART NUMBER
355	Valve Assembly *	1	26170	381	Guide	1	52233
371	End Cap	1	52241	382	Spring	1	52240
372	Gasket	2	52457	383	Washer	1	52239
373	Valve Body	1	**	384	Spacer	1	52238
374	Nut	1	50176	385	'O' Ring	6	52456
375	End Cap (Inlet Side)	1	11778	386	Valve Sleeve	1	**
376	Capscrew	8	71327738	387	Valve Spool	1	**
377	Adjusting Screw	1	71327720	388	Fitting, Elbow	1	71330112
378	Nut	1	71069132	402	Fitting, Nipple	1	71057483
379	Shoulder Screw	1	54710	403	Muffler	1	52472

KIT DESCRIPTION	PART NUMBER
<ul style="list-style-type: none"> Control Valve Service Kit (includes items 372 (qty 2) and 385 (qty 6)) 	71356398

☐ Recommended spares for 1 winch, 2 years of normal service.

- * Valve Assembly (355) includes items 371–387.
- ** Valve Body (373), Valve Sleeve (386) and Valve Spool (387) are not sold separately. To replace these items order Valve Assembly (355).

REMOTE FULL FLOW VALVE ASSEMBLY DRAWING AND PARTS LIST

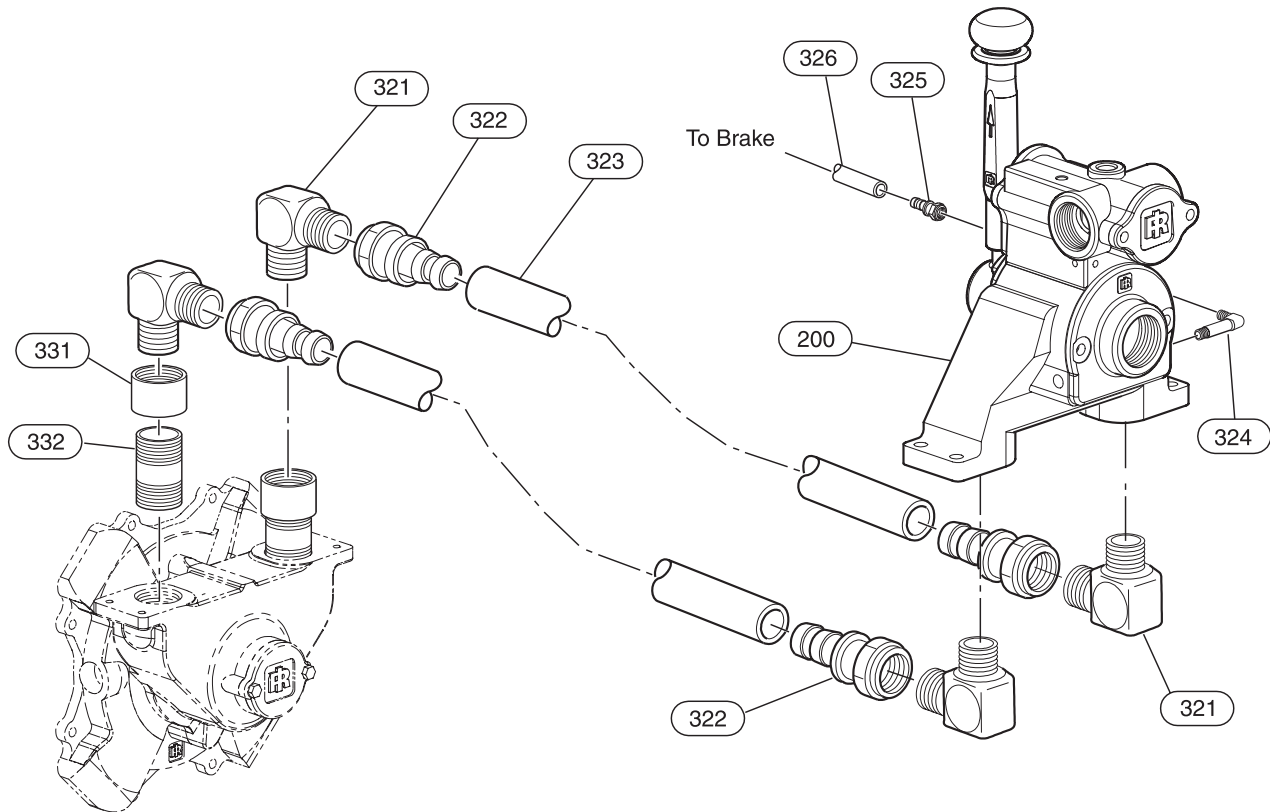

(Dwg. MHP1841)

ITEM NO.	DESCRIPTION OF PART	QTY TOTAL	PART NUMBER
200	Control Valve Assembly	1	K5C
321	Fitting, Elbow	4	54270
322	Hose End	4	54738
323	Hose, Bulk	2	54737-**
324	Fitting, Elbow	1	52182
325	Hose End	2	51029
326	Hose, Bulk	As required	50923-**
331	Fitting, Coupling	2	71046379
332	Fitting, Nipple	2	71068886

* Add hose length (feet/metres). Maximum length = 20 ft (6 metres). Contact Technical Sales for information on control applicability for lengths greater than 20 feet (6 metres). Metres are for reference only; order quantities in feet.

** Order in even foot increments; i.e., 54737-03 = 3 feet (1 metre).

HU40A WINCH VALVE CHEST ASSEMBLY PARTS LIST

ITEM NO.	DESCRIPTION OF PART	QTY TOTAL	PART NUMBER
712	Pipe Plug	1	D02-402
718	Cotter Pin	2	53456
750	Valve Chest Assembly (includes items 751-782)	1	HU-A545A
751	Valve Cap	1	HU-943
752	Retainer Ring	1	D02-940Z
753	Spring	1	HU-942
755	Throttle Valve	1	HU-940
757	Poppet	1	HU-940
758	Ball	1	D10-280
759	Cover	1	HU-546A
761	Lockwasher (1 set = quantity 10)	1 Set	D02-321-10
762	Capscrew	4	HU-548
763	Throttle Spring	1	HU-412
764	Fitting, Grease	2	53095
765	Valve Chest Housing	1	HU-545A
768	Rotary Valve	1	HU-526A
769	Pin	1	HU-527
771	Throttle Control Arm	1	HU-555A
772	Pin	1	HU-870
773	Throttle Lever	1	HU-556
774	Throttle Lever Latch	1	HU-869
775	Spring	1	HU-567
776	Setscrew	1	HU-842
777	Pin	1	HU-627
778	Reverse Valve	1	HU-K744A
781	Stop Pin	1	D02-553

AMP94A WINCH VALVE CHEST ASSEMBLY DRAWING AND PARTS LIST

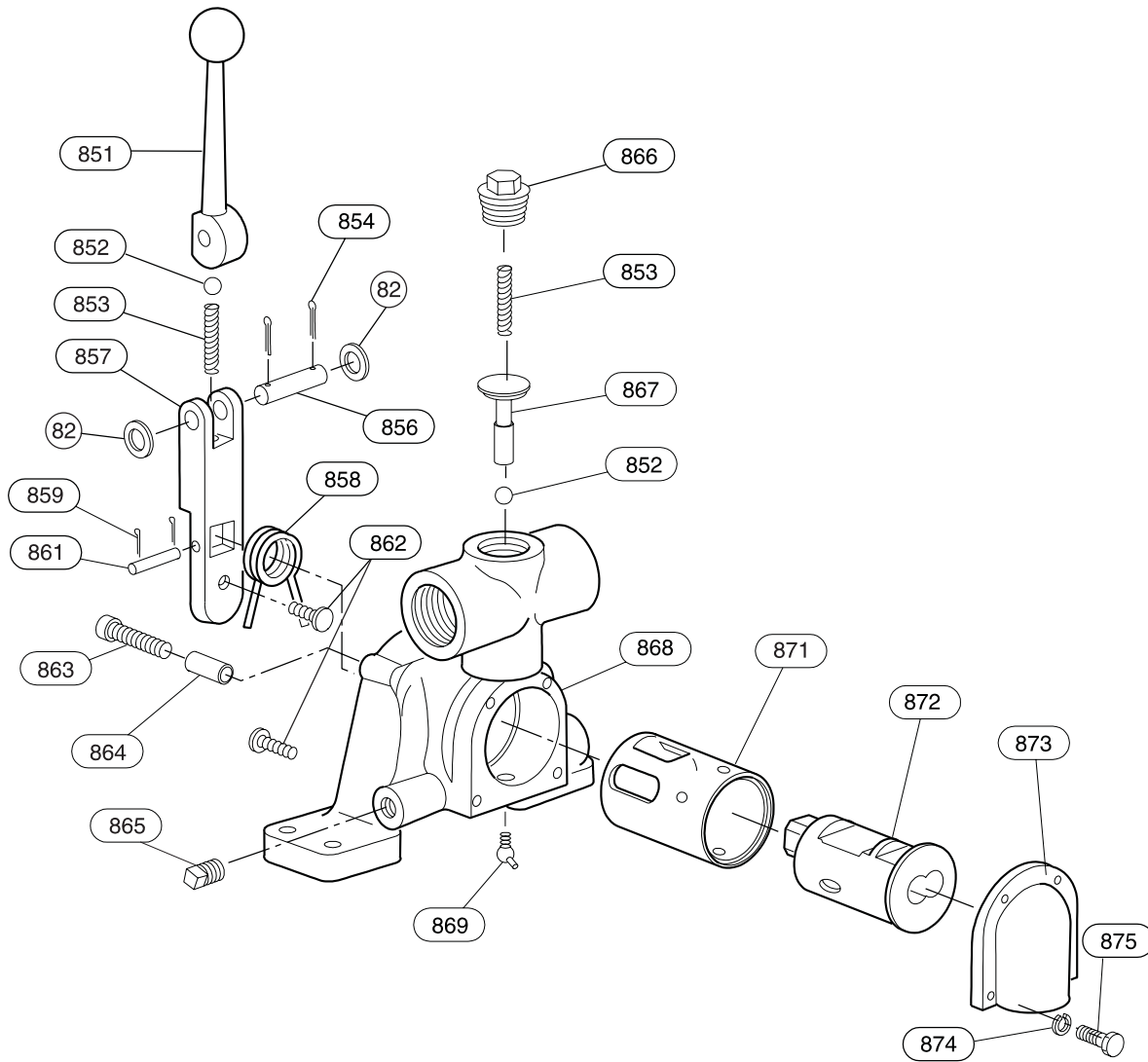

(Dwg. MHP1844)

ITEM NO.	DESCRIPTION OF PART	QTY TOTAL	PART NUMBER	ITEM NO.	DESCRIPTION OF PART	QTY TOTAL	PART NUMBER
82	Washer	2	52914	863	Capscrew	2	51025
850	Valve Assembly (incl's items 82 and 851-875)	1	51710	864	Sleeve	2	71077473
851	Handle	1	11882	865	Pipe Plug	1	51599
852	Ball	2	71077119	866	Pipe Plug	1	11886
853	Spring	2	11862	867	Poppet Valve	1	11879
854	Cotter Pin	2	71077101	868	Housing	1	*
856	Pin	1	11860	869	Grease Fitting	1	50192
857	Handle Bracket	1	11878	871	Valve Bushing	1	11883
858	Spring	1	11880	872	Valve	1	11865
859	Cotter Pin	2	52161	873	Exhaust Cover	1	11881
861	Pin	1	11861	874	Lockwasher	4	51801
862	Screw	2	11884	875	Capscrew	2	51770

FA2B WINCH MOTOR MUFFLER ASSEMBLY DRAWING AND PARTS LIST

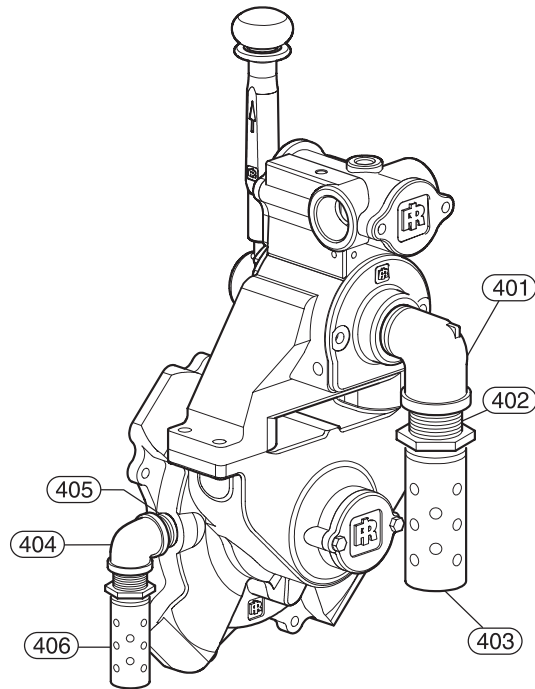

(Dwg. MHP1855)

ITEM NO.	DESCRIPTION OF PART	QTY TOTAL	PART NUMBER
401	Fitting, Elbow	1	71273676
402	Fitting, Nipple	1	71057483
403	Muffler	1	52472
404	Fitting, Elbow	1	50928
405	Fitting, Nipple	1	54267
406	Muffler	1	50592

OPEN FRAME (FACE) ASSEMBLY DRAWING AND PARTS LIST

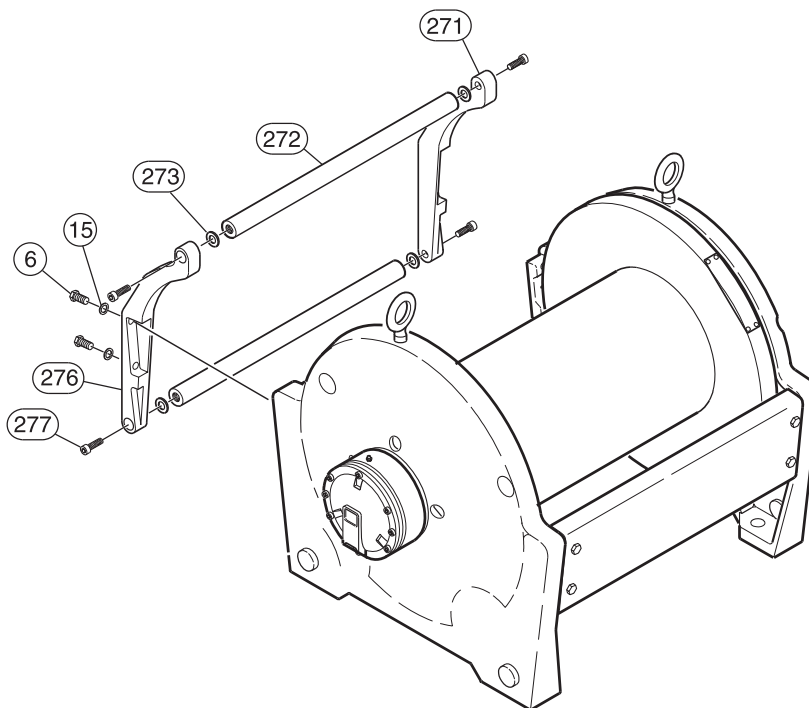

(Dwg. MHP1374)

ITEM NO.	DESCRIPTION OF PART	QTY TOTAL	PART NUMBER
6	Capscrew	4	71306435
15	Washer	4	71274807
	Open Frame Assembly (includes items 6, 15 and 271-277)		
270	Short Drum (7 inch) without Band Brake	1	26330-1
	Short Drum (7 inch) with Band Brake		26330-4
	Medium Drum (13-1/2 inch) without Band Brake		26330-2
	Medium Drum (13-1/2 inch) with Band Brake		26330-5
	Long Drum (20 inch) without Band Brake		26330-3
	Long Drum (20 inch) with Band Brake		26330-6
	Extra long Drum (24 inch) without Band Brake		26330-7
	Extra long Drum (24 inch) with Band Brake		26330-8
271	Sideframe, Motor End	1	26331
272	Support Bar, Short Drum (7 inch) without Band Brake	1	25671-1
	Support Bar, Short Drum (7 inch) with Band Brake		25671-4
	Support Bar, Medium Drum (13-1/2 inch) without Band Brake		25671-2
	Support Bar, Medium Drum (13-1/2 inch) with Band Brake		25671-5
	Support Bar, Long Drum (20 inch) without Band Brake		25671-3
	Support Bar, Long Drum (20 inch) with Band Brake		25671-6
	Support Bar, Extra long Drum (24 inch) without Band Brake		25671-7
	Support Bar, Extra long Drum (24 inch) with Band Brake		25671-8
273	Washer	4	52915
276	Sideframe	1	23662
277	Capscrew	4	71306450

DRUM GUARD ASSEMBLY DRAWING AND PARTS LIST

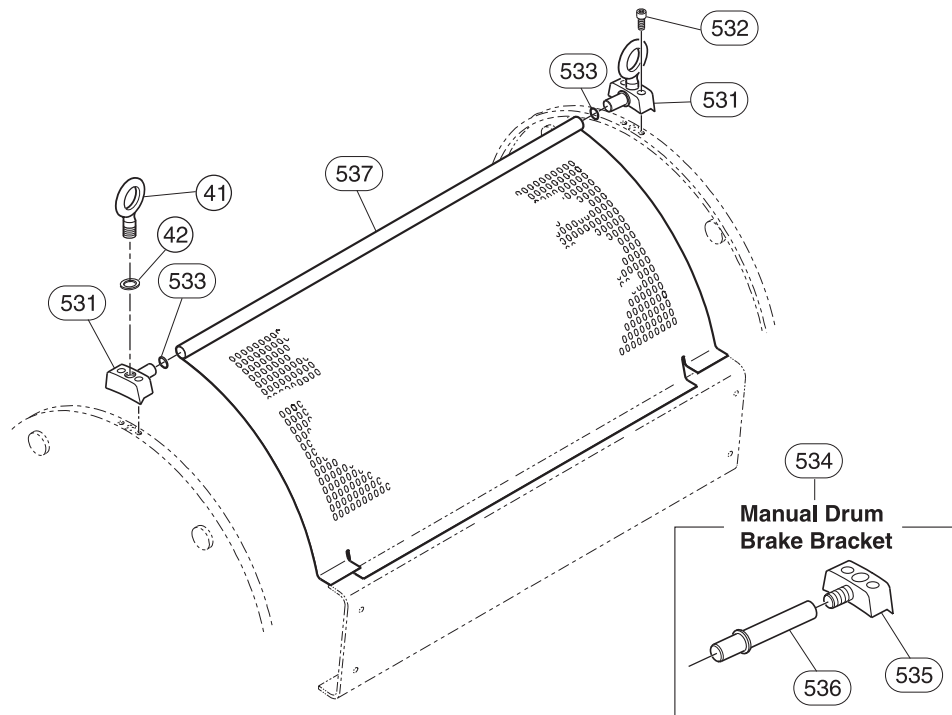

(Dwg. MHP1110)

ITEM NO.	DESCRIPTION OF PART	QTY TOTAL	PART NUMBER
41	Eyebolt	2	71352868
42	Washer	2	71352884
530	Drum Guard Assembly (includes items 531-537)		
	Short Drum (7 inch) without Band Brake	1	25296
	Short Drum (7 inch) with Manual Band Brake		26317-1
	Short Drum (7 inch) with Automatic Band Brake		25294
	Medium Drum (13-1/2 inch) without Band Brake		25256
	Medium Drum (13-1/2 inch) with Manual Band Brake		26317-2
	Medium Drum (13-1/2 inch) with Automatic Band Brake		25295
	Long Drum (20 inch) without Band Brake		25293
	Long Drum (20 inch) with Manual Band Brake		26317-3
	Long Drum (20 inch) with Automatic Band Brake		25297
	Extra long Drum (24 inch) without Band Brake		25737
	Extra long Drum (24 inch) with Manual Band Brake		26317-4
	Extra long Drum (24 inch) with Automatic Band Brake		25738
531	Bracket, Drum Guard with Band Brake		1
	Bracket, Drum Guard without Band Brake	2	
532	Capscrew	4	71261739
533	Washer	2	71296800
534	Bracket Assembly Band Brake (includes items 535 and 536)	1	27173
535	Bracket Base	1	27171
536	Bracket Shaft	1	27172
537	Drum Guard		
	Short Drum (7 inch) without Band Brake and Manual Band Brake	1	25298
	Short Drum (7 inch) with Automatic Band Brake		25299
	Medium Drum (13-1/2 inch) without Band Brake and Manual Band Brake		25255
	Medium Drum (13-1/2 inch) with Automatic Band Brake		25300
	Long Drum (20 inch) without Band Brake and Manual Band Brake		25301
	Long Drum (20 inch) with Automatic Band Brake		25302
	Extra long Drum (24 inch) without Band Brake and Manual Band Brake		26257
Extra long Drum (24 inch) with Automatic Band Brake	26258		

FREE SPOOL ASSEMBLY PARTS DRAWING AND PARTS LIST

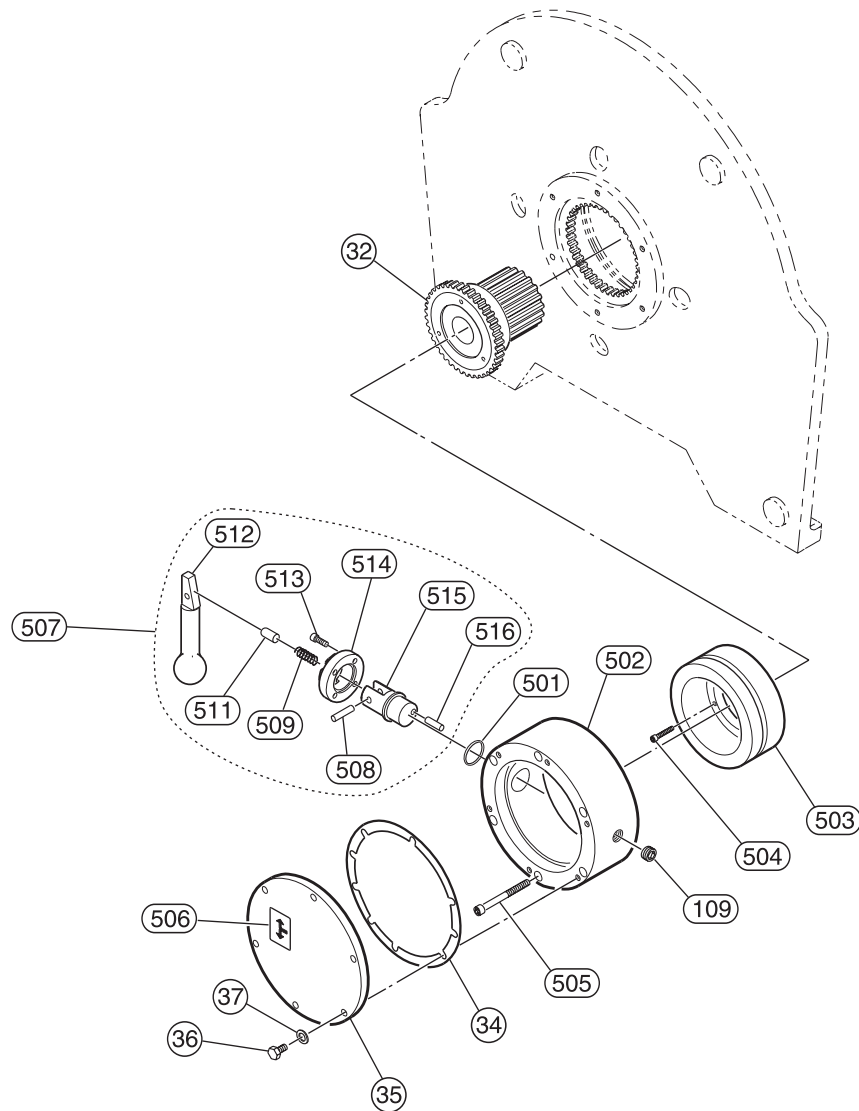

(Dwg. MHP1828)

ITEM NO.	DESCRIPTION OF PART	QTY TOTAL	PART NUMBER	ITEM NO.	DESCRIPTION OF PART	QTY TOTAL	PART NUMBER
500	Freespool Assembly (includes items 34–37, 109 and 501–507)	1	26183	505	Capscrew	6	71138275
				506	Label, Instruction	1	71328793
32	Output Shaft †	1	24817	507	Shifter Assembly (includes items 508-516)	1	26172
34	Gasket	1	71262257				
35	Cover	1	21732	508	Pin	1	71328173
36	Capscrew	6	71266613	509	Spring	1	71328181
37	Washer	6	71303408	511	Latch	1	HU-566
109	Plug	1	71069009	512	Handle	1	HU-565P
501	'O' Ring	1	71137988	513	Capscrew	4	71307284
502	Housing	1	26174	514	Detent Plate	1	26182
503	Shaft Support	1	22257	515	Shifter	1	26173
504	Capscrew	3	71138267	516	Dowel Pin	1	71053722

† These parts also come in a cold weather version. For winches with a –C in the model code, adding CH to the end of these part numbers is required to retain winch certification. Example: Order Output Shaft (item 32) part number 24817 as part number 24817CH.

ACCESSORIES

DESCRIPTION OF ACCESSORY	PART NUMBER
Thermoplastic Powder (4 ounces)	71308902
Propane Torch	71308886
Heat Gun	71308894
Muffler (quantity of 2 required for '-E' Option winches)	52472
Infrared Thermometer	71308878
Lubricant (16 fluid ounces)	LUBRI-LINK-GREEN
Filter 1-1/2 inch NPT	F35-0B-C28
Regulator - 1-1/2 inch NPT	R40-0B-G00
Lubricator 1-1/2 inch NPT	L4-0B-000
Liquidator 2 inch FNPT (not shown on drawing)	8834-WI-000
Pipeline Strainer 1-1/4 FNPT (not shown on drawing)	K4U-A267AT

KITS

DESCRIPTION OF KIT	KIT PART NUMBER
Natural Gas	
FA2B Motor - Natural Gas Conversion Kit	26974
FA2B Winch - Natural Gas Conversion Kit	27197
FA2B Winch - Cage Kit (Part Number requires winch model code; refer to "SPECIFICATIONS" section on page 5 and winch nameplate located on outboard upright.	CC-(Model Code)

ELECTRIC MOTOR SPECIFICATIONS

Electrical Specifications

Provide a power supply of 460 volts, 110 amps as measured at the motor.

Rated Performance		Motor Model			
		FE2B (1200 rpm @ 60Hz, continuous duty)			
		Lifting (5:1 design factor)		Pulling (3.5:1 design factor)	
1st Layer	Rated Load	5170* lbs	2345 kg	5170* lbs	2345 kg
	Rated Speed	77 fpm	23 m/min	77 fpm	23 m/min
Mid Layer	Rated Load	4000 lbs	1814 kg	4000 lbs	1814 kg
	Rated Speed	100 fpm	30 m/min	100 fpm	30 m/min
Top Layer	Rated Load	3260 lbs	1479 kg	3260 lbs	1479 kg
	Rated Speed	123 fpm	37 m/min	123 fpm	37 m/min
Full Current Load		19 amps @ 460V			
Maximum Current Draw (Locked Rotor)		110 amps @ 460 V			

* Operating winch at these loads exceed ASME B30.7 lifting or pulling design guidelines.

To convert an FA2B Air powered winch to an FE2B Electric powered winch, order Interface Conversion Kit Part Number 27249. Contact Factory for additional information. Interface Conversion Kit (26727) provides components enabling a NEMA 215TC electric motor type to replace an air motor on winch upright.

HYDRAULIC MOTOR SPECIFICATIONS

Hydraulic Specifications

Provide a hydraulic oil supply specified in table heading, as measured at the motor.

Rated Performance		Motor Model			
		FH2B			
		Lifting (5:1 design factor)		Pulling (3.5:1 design factor)	
Pressure and Flow Rate		1850 psig @ 25 gpm	12759 kPa/128 bar @ 95 l/m	2350 psig @ 25 gpm	16207 kPa/162 bar @ 95 l/m
1st Layer	Rated Load	5170* lbs	2345 kg	7360* lbs	3338 kg
	Rated Speed	93 fpm	28 m/min	93 fpm	28 m/min
Mid Layer	Rated Load	4000 lbs	1814 kg	5700 lbs	2585 kg
	Rated Speed	112 fpm	34 m/min	112 fpm	34 m/min
Top Layer	Rated Load	3260 lbs	1479 kg	4600 lbs	2086 kg
	Rated Speed	138 fpm	42 m/min	138 fpm	42 m/min
Consumption at Maximum Horsepower		45 gpm (170 l/m) @ 2500 psi (17241 kPa/172 bar)			

* Operating winch at these loads exceed ASME B30.7 lifting or pulling design guidelines.

To convert an FA2B Air powered winch to an FH2B Hydraulic powered winch, order Interface Conversion Kit Part Number 27248. Contact Factory for additional information. Interface Conversion Kit (26726) provides components enabling a 2 or 4 bolt SAE 'B' hydraulic motor to replace air motor on winch upright.

WINCH LABEL/TAG LOCATION DRAWING

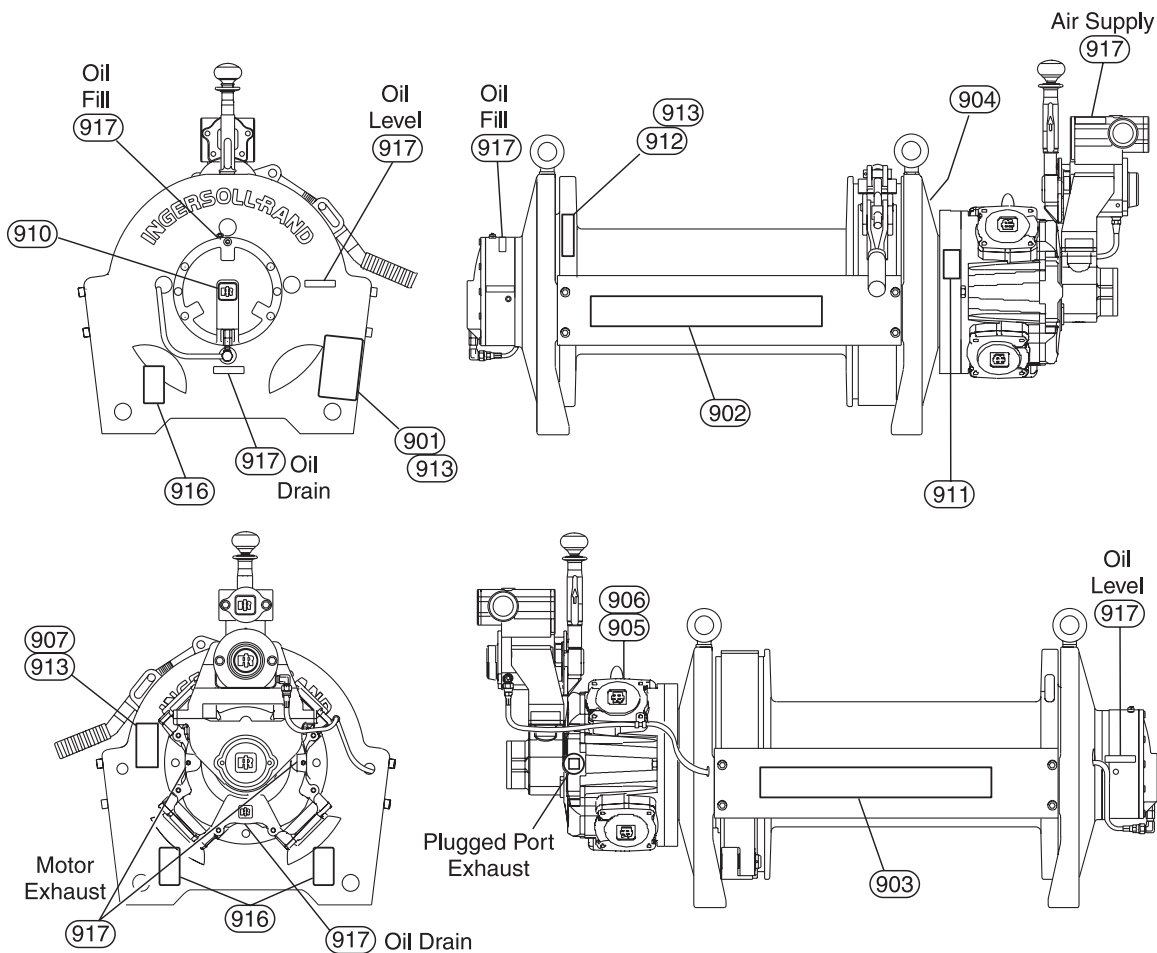

(Dwg. MHP1825)

ITEM NO.	DESCRIPTION OF PART	QTY TOTAL	PART NUMBER		
			Short Drum	Medium Drum	Long Drum and Extra Long Drum
900	Label Kit (includes 901-917)	1	27290-1	27290-2	27290-3
901	Nameplate	1	71106991-R		
902	Label, IR Logo	1	71106231	71106256	71106272
903	Label, Product	1	71302640	71111769	71111777
904	Label, Throttle Direction	1	71297816		
905	Label, Do Not Lift	1	71355655		
906	Wire Tie	1	54235		
907	Warning, General	1	71056410		
910	Label, IR Monogram	1	71137780		
911	Label, Warning	1	04306445		
912	Label, Cover Anchor Pocket	1	71297824		
913	Rivet	9	50915		
916	Warning Label, Do Not Weld	3	71270813		
917	Label Sheet, Air Units †	1	71295240		
*	Label, Filter Lubricator ††	1	71319768		

* Not shown on drawing.

† Includes Oil Drain, Air Supply and Exhaust labels for FA2B air motor; includes Oil Drain, Oil Level, Oil Fill, Air Supply and Exhaust labels for HU40A and AMP94A air motors.

†† HU40A and AMP94A Air Motors only.

PARTS ORDERING INFORMATION

The use of other than **Ingersoll-Rand** Material Handling replacement parts may adversely affect the safe operation and performance of this product. For your convenience and future reference it is recommended that the following information be recorded.

Model Number _____

Serial Number _____

Date Purchased _____

When ordering replacement parts, please specify the following:

1. Complete model number and serial number as it appears on the nameplate.
2. Part number(s) and part description as shown in this manual.
3. Quantity required.

The nameplate is located on the winch outboard upright.

NOTICE

- **Continuing improvement and advancement of design may cause changes to this equipment which are not included in this manual. Manuals are periodically revised to incorporate changes. Always check the manual edition number on the front cover for the latest issue.**
- **Sections of this manual may not apply to your winch.**

Refer all communications to the nearest **Ingersoll-Rand** Material Handling Office or Distributor.

Traceability

Load bearing parts are documented to provide traceability. The documentation includes chemical and physical properties of the raw material, heat treating, hardening, tensile and charpy tests as required for the part. Units with M2 or M3 in the model code have traceable load-bearing components. Components with part numbers ending in CH are charpy parts for use under extreme cold conditions. Traceability requirements must be stated when reordering these parts for continued certification.

Return Goods Policy

Ingersoll-Rand will not accept any returned goods for warranty or service work unless prior arrangements have been made and written authorization has been provided from the location where the goods were purchased.

Winches that have been modified without **Ingersoll-Rand** approval, mishandled or overloaded will not be repaired or replaced under warranty. A printed copy of the warranty which applies to this winch is provided inside the back cover of this manual.

Disposal

When the life of the unit has expired, it is recommended that the unit be disassembled, degreased and parts separated as to materials so that they may be recycled.

For additional information contact:

Ingersoll-Rand Material Handling
P.O. Box 24046
2724 Sixth Avenue South
Seattle, WA 98124-0046 USA
Phone: (206) 624-0466
Fax: (206) 624-6265

or

Ingersoll-Rand Material Handling
Douai Operations
111, avenue Roger Salengro
59450 Sin Le Noble, France
Phone: (33) 3-27-93-08-08
Fax: (33) 3-27-93-08-00

PUBLICATION REFERENCE

For additional information on this product order the publication by the referenced Part/Document Number listed:

Publication	Part/Document Number	Publication	Part/Document Number
Brake Lining Replacement Instruction Sheet	MHD56142	Man-Rider® Supplement	MHD56042

WARRANTY

LIMITED WARRANTY

Ingersoll-Rand Company (I-R) warrants to the original user its Products to be free of defects in material and workmanship for a period of one year from the date of purchase. **I-R** will repair, without cost, any Product found to be defective, including parts and labor charges, or at its option, will replace such Products or refund the purchase price less a reasonable allowance for depreciation, in exchange for the Product. Repairs or replacements are warranted for the remainder of the original warranty period.

If any Product proves defective within its original one year warranty period, it should be returned to any Authorized Hoist and Winch Service Distributor, transportation prepaid with proof of purchase or warranty card.

This warranty does not apply to Products which **I-R** has determined to have been misused or abused, improperly maintained by the user, or where the malfunction or defect can be attributed to the use of non-genuine **I-R** parts.

I-R makes no other warranty, and all implied warranties including any warranty of merchantability or fitness for a particular purpose are limited to the duration of the expressed warranty period as set forth above. I-R's maximum liability is limited to the purchase price of the Product and in no event shall I-R be liable for any consequential, indirect, incidental, or special damages of any nature rising from the sale or use of the Product, whether based on contract, tort, or otherwise.

Note: Some states do not allow limitations on incidental or consequential damages or how long an implied warranty lasts so that the above limitations may not apply to you.

This warranty gives you specific legal rights and you may also have other rights which may vary from state to state.

IMPORTANT NOTICE

It is our policy to promote safe delivery of all orders. This shipment has been thoroughly checked, packed and inspected before leaving our plant and receipt for it in good condition has been received from the carrier. Any loss or damage which occurs to this shipment while en route is not due to any action or conduct of the manufacturer.

Visible Loss or Damage

If any of the goods called for on the bill of lading or express receipt are damaged or the quantity is short, do not accept them until the freight or express agent makes an appropriate notation on your freight bill or express receipt.

Concealed Loss or Damage

When a shipment has been delivered to you in apparent good condition, but upon opening the crate or container, loss or damage has taken place while in transit, notify the carrier's agent immediately.

Damage Claims

You must file claims for damage with the carrier. It is the transportation company's responsibility to reimburse you for repair or replacement of goods damaged in shipment. Claims for loss or damage in shipment must not be deducted from the **Ingersoll-Rand** invoice, nor should payment of **Ingersoll-Rand** invoice be withheld awaiting adjustment of such claims as the carrier guarantees safe delivery.

You may return products damaged in shipment to us for repair, which services will be for your account and form your basis for claim against the carrier.

United States Office Locations

For Order Entry and Order Status

**Ingersoll-Rand
Distribution Center**
P.O. Box 618
510 Hester Drive
White House, TN 37188
Phone: (615) 672-0321
Fax: (615) 672-0801

Technical Support

**Ingersoll-Rand
Material Handling**
P.O. Box 24046
2724 Sixth Avenue South
Seattle, WA 98124-0046 USA
Phone: (206) 624-0466
Fax: (206) 624-6265

Web Site:

www.ingersoll-rand.com

Regional Sales Offices

Chicago, IL
888 Industrial Drive
Elmhurst, IL 60126
Phone: (630) 530-3800
Fax: (630) 530-3891

Detroit, MI
23192 Commerce Drive
Farmington Hills, MI 48335
Phone: (248) 476-6677
Fax: (248) 476-6670

Houston, TX
450 Gears Road
Suite 210
Houston, TX 77067-4516
Phone: (281) 872-6800
Fax: (281) 872-6807

Los Angeles, CA
11909 E. Telegraph Road
Santa Fe Springs, CA
90670-0525
Phone: (562) 948-4189
Fax: (562) 948-1828

Philadelphia, PA
P.O. Box 425
900 E. 8th Ave., Suite 103
King of Prussia, PA 19406
Phone: (610) 337-5930
Fax: (610) 337-5912

International Office Locations

Offices and distributors in principal cities throughout the world. Contact the nearest **Ingersoll-Rand** office for the name and address of the distributor in your country or write/fax to:

**Ingersoll-Rand
Material Handling**
P.O. Box 24046
2724 Sixth Avenue South
Seattle, WA 98124-0046 USA
Phone: (206) 624-0466
Fax: (206) 624-6265

**Canada
National Sales Office
Regional Warehouse
Toronto, Ontario**
51 Worcester Road
Rexdale, Ontario
M9W 4K2
Phone: (416) 213-4500
Fax: (416) 213-4510
Order Desk
Fax: (416) 213-4506

**Regional Sales Offices
Edmonton, Alberta**
1430 Weber Center
5555 Calgary Trail N.W.
Edmonton, Alberta
T6H 2P9
Phone: (403) 438-5039
Fax: (403) 437-3145

Montreal, Quebec
3501 St. Charles Blvd.
Kirkland, Quebec
H9H 4S3
Phone: (514) 695-9040
Fax: (514) 695-0963

British Columbia
1200 Cliveden Avenue
Delta, B. C.
V3M 6G4
Phone: (604) 523-0803
Fax: (604) 523-0801

**Latin America Operations
Ingersoll-Rand
Production Equipment Group**
730 N.W. 107 Avenue
Suite 300, Miami, FL, USA
33172-3107
Phone: (305) 559-0500
Fax: (305) 222-0864

**Europe, Middle East and
Africa
Ingersoll-Rand
Material Handling
Douai Operations**
111, avenue Roger Salengro
59450 Sin Le Noble, France
Phone: (33) 3-27-93-08-08
Fax: (33) 3-27-93-08-00

**Asia Pacific Operations
Ingersoll-Rand Asia Pacific Inc.**
Suite 1201-3, 12/F
Central Plaza
18 Harbour Road
Wanchai, Hong Kong
Phone: (852) 9794 1673
Fax: (852) 9794 7895

**Russia
Ingersoll-Rand**
Kuznetsky Most 21/5
Entrance 3
Moscow 103895 Russia
Phone: 7-501-923-91-34
Fax: 7-501-924-46-25