

L2680 Rev. D 08/16

Index:	
English.....	1-5
Français.....	6-11
Deutsch.....	12-17
Italiano.....	18-22
Español.....	23-27
Nederlands.....	28-33
Portuguese.....	34-38
Finnish.....	39-43
Norwegian.....	44-48
Swedish.....	49-53
中文.....	54-58
日本語.....	59-63

Repair Parts Sheets for this product are available from the Enerpac web site at [www.enerpac.com](http://www.enerpac.com), or from your nearest Authorized Enerpac Service Center or Enerpac Sales office.

**1.0 IMPORTANT RECEIVING INSTRUCTIONS**

Visually inspect all components for shipping damage. Shipping damage is not covered by warranty. If shipping damage is found, notify carrier at once. The carrier is responsible for all repair and replacement costs resulting from damage in shipment.

**SAFETY FIRST**

**2.0 SAFETY ISSUES**



Read all instructions, warnings and cautions carefully. Follow all safety precautions to avoid personal injury or property damage during system operation. Enerpac cannot be responsible for damage or injury resulting from unsafe product use, lack of maintenance or incorrect product and/or system operation. Contact Enerpac when in doubt as to the safety precautions and operations. If you have never been trained on high-pressure hydraulic safety, consult your distribution or service center for a free Enerpac Hydraulic safety course.

Failure to comply with the following cautions and warnings could cause equipment damage and personal injury.

A **CAUTION** is used to indicate correct operating or maintenance procedures and practices to prevent damage to, or destruction of equipment or other property.

A **WARNING** indicates a potential danger that requires correct procedures or practices to avoid personal injury.

A **DANGER** is only used when your action or lack of action may cause serious injury or even death.



**WARNING:** Wear proper personal protective gear when operating hydraulic equipment.



**WARNING:** Stay clear of loads supported by hydraulics. A cylinder, when used as a load lifting device, should never be used as a load holding device. After the load has been raised or lowered, it must always be blocked mechanically.



**WARNING: USE ONLY RIGID PIECES TO HOLD LOADS.** Carefully select steel or wood blocks that are capable of supporting the load. Never use a hydraulic cylinder as a shim or spacer in any lifting or pressing application.



**DANGER:** To avoid personal injury keep hands and feet away from cylinder and workpiece during operation.



**WARNING:** Do not exceed equipment ratings. Never attempt to lift a load weighing more than the capacity of the cylinder. Overloading causes equipment failure and possible personal injury. The cylinders are designed for a max. pressure of 700 bar [10,000 psi]. Do not connect a jack or cylinder to a pump with a higher pressure rating.



Never set the relief valve to a higher pressure than the maximum rated pressure of the pump. Higher settings may result in equipment damage and/or personal injury.



**WARNING:** The system operating pressure must not exceed the pressure rating of the lowest rated component in the system. Install pressure gauges in the system to monitor operating pressure. It is your window to what is happening in the system.



**CAUTION:** Avoid damaging hydraulic hose. Avoid sharp bends and kinks when routing hydraulic hoses. Using a bent or kinked hose will cause severe back-pressure. Sharp bends and kinks will internally damage the hose leading to premature hose failure.



Do not drop heavy objects on hose. A sharp impact may cause internal damage to hose wire strands. Applying pressure to a damaged hose may cause it to rupture.



**IMPORTANT:** Do not lift hydraulic equipment by the hoses or swivel couplers. Use the carrying handle or other means of safe transport.



**CAUTION:** Keep hydraulic equipment away from flames and heat. Excessive heat will soften packings and seals, resulting in fluid leaks. Heat also weakens hose materials and packings. For optimum performance do not expose equipment to temperatures of 65°C [150°F] or higher. Protect hoses and cylinders from weld spatter.



**DANGER:** Do not handle pressurized hoses. Escaping oil under pressure can penetrate the skin, causing serious injury. If oil is injected under the skin, see a doctor immediately.



**WARNING:** Only use hydraulic cylinders in a coupled system. Never use a cylinder with unconnected couplers. If the cylinder becomes extremely overloaded, components can fail catastrophically causing severe personal injury.



**WARNING: BE SURE SETUP IS STABLE BEFORE LIFTING LOAD.** Cylinders should be placed on a flat surface that can support the load. Where applicable, use a cylinder base for added stability. Do not weld or otherwise modify the cylinder to attach a base or other support.



**Avoid** situations where loads are not directly centered on the cylinder plunger. Off-center loads produce considerable strain on cylinders and plungers. In addition, the load may slip or fall, causing potentially dangerous results.



Distribute the load evenly across the entire saddle surface. Always use a saddle to protect the plunger.



**IMPORTANT:** Hydraulic equipment must only be serviced by a qualified hydraulic technician. For repair service, contact the Authorized ENERPAC Service Center in your area. To protect your warranty, use only ENERPAC oil.



**WARNING:** Immediately replace worn or damaged parts by genuine ENERPAC parts. Standard grade parts will break causing personal injury and property damage. ENERPAC parts are designed to fit properly and withstand high loads.



**WARNING:** Do not use electric pumps in an explosive atmosphere. Adhere to all local and national electrical codes. A qualified electrician must do installation and modification.



**WARNING:** Keep hands clear of moving parts and pressurized hoses.



**WARNING:** These pumps have internal factory adjusted relief valves, which must not be repaired or adjusted except by an Authorized Enerpac Service Center.



**CAUTION:** To prevent damage to pump electric motor, check specifications. Use of incorrect power source will damage the motor.



Hot surfaces inside. Contact may cause burn. Do not touch. Allow to cool before servicing.



**INHALATION HAZARD.** Do NOT breathe exhaust. Toxic gases or fumes may be present. Follow approved procedures before operating or servicing.

Use adequate ventilation to maintain safe occupational exposure limits. Do NOT use inside a closed environment.



Protective gloves must be worn.



Safety glasses must be worn.



Loud noise hazard. Ear protection must be worn.



Flammable material. Keep fire away.

### 3.0 SPECIFICATIONS

#### 3.1 Performance Chart (see Performance Chart below)

#### 3.2 Flow Chart

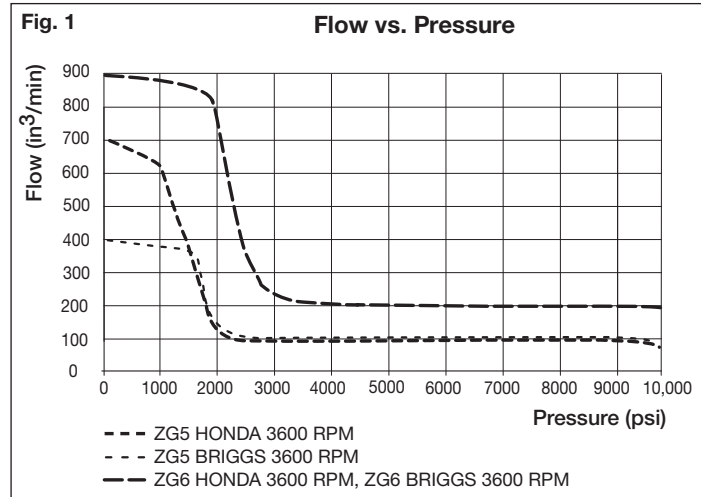

### ▼ ZG PERFORMANCE CHART

Motor Manufacturer	Motor Size (hp)	Output Flow Rate (in <sup>3</sup> /min)				Sound Level (dBA)	Relief Valve Adjustment Range (psi)
		100 psi	700 psi	5,000 psi	10,000 psi		
Briggs & Stratton	6.5	400	380	110	100	91-95	1000-10,000
Honda	5.5	700	650	110	100	88-93	
Honda	13.0	900	885	225	200	91-95	
Briggs & Stratton	10.5	900	885	225	200	91-95	
Briggs & Stratton	13.0	900	885	225	200	91-95	

## 4.0 INSTALLATION

Install or position the pump to ensure that air flow around the engine and pump is unobstructed.

### 4.1 Reservoir Breather Cap (See Figure 2)

For shipping purposes, a shipping plug (A) is installed in the breather port on the top of the reservoir. Before using replace the shipping plug with the breather cap (B). NOTE: The breather port (B) is separate from the oil fill port (C). Oil fill port (C) uses a SAE #10 plug.

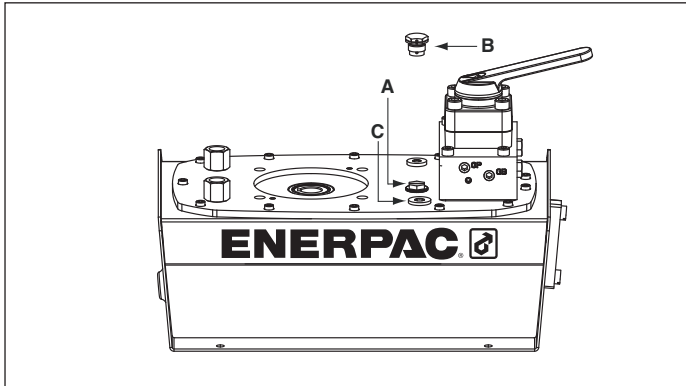

Figure 2, ZG Breather Installation

### 4.2 Pump Mounting

Refer to Figure 3 for mounting dimensions to secure the pump to a fixed surface.

	2.5 Gal, (10 L) in. (mm)	5 Gal, (20 L) in. (mm)	10 Gal, (40 L) in. (mm)
A	12.0 (305)	16.6 (421)	19.9 (505)
B	11.0 (279)	15.6 (396)	18.9 (480)
C	17.6 (446)	17.6 (446)	17.6 (446)
D	12.0 (305)	12.0 (305)	12.0 (305)
E	0.5 (13)	0.5 (13)	0.5 (13)
F	2.8 (71)	2.8 (71)	2.8 (71)
G	Ø .34 (8.6) diameter through hole		

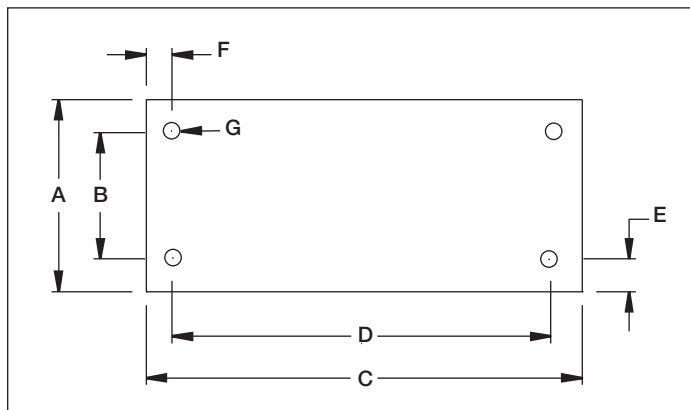

Figure 3

### 4.3 Fluid Level

Check the oil level of the pump prior to start-up, if necessary add oil by removing the SAE #10 plug from the cover plate (see Fig. 2). The reservoir is full when the oil level reaches the top of the sight glass. (Fig. 4).

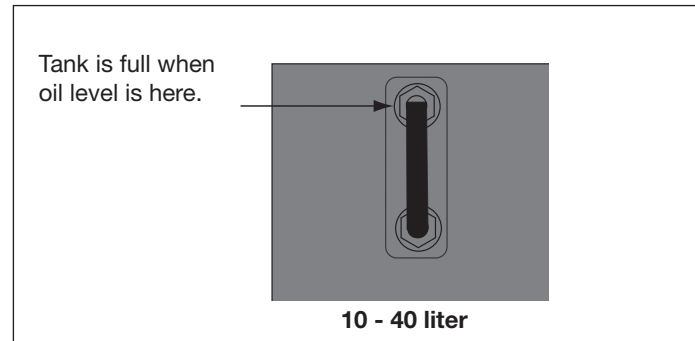

Figure 4

**IMPORTANT:** Add oil only when all system components are fully retracted, or the system will contain more oil than the reservoir can hold.

### 4.4 Hydraulic Connections

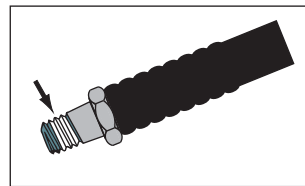

Figure 5

Apply 1-1/2 wraps of Teflon tape or other suitable sealant to the hydraulic hose fitting, leaving the first complete thread free of tape or sealant as shown in Figure 5.

Thread hose(s) into outlet port(s) of the valve (see valve body for port identification).

Extend hose to valve port "A"

Retract hose to valve port "B" (if applicable).

Gauge to valve port "GA, GB, or GP".

("GA" measures "A" port pressure, "GB" measures "B" port pressure, "GP" measures pump pressure down stream of system check).

### 4.5 Battery Cable Connection (ZG6 model only)

The negative battery cable is disconnected before shipping for safety reasons. Insert cable over battery terminal and secure by tightening screw.

## 5.0 OPERATION

1. Check gas and engine oil level. See engine Owner's manual for instructions and recommended fluids.
2. Check all system fittings and connections to be sure they are tight and leak free.
3. Make sure the shipping plug has been removed and the breather cap is installed. (See section 4.1)
4. Place manual control valve in the Neutral position.
5. Start engine following procedure in engine Owner's Manual.

**NOTE:** ZG6 model is equipped with electric start. Insert key supplied with pump into key slot on the control panel.

- a. Push the throttle above the top detent position, which is the choke position. The detent in the top position is the fast throttle, and above this position is the engine choke position.

- b. Turn key to the right until engine starts.

- c. Lower the throttle down to the detent position for maximum performance. The throttle may be lowered below the detent for idle. (See Figure 6.)

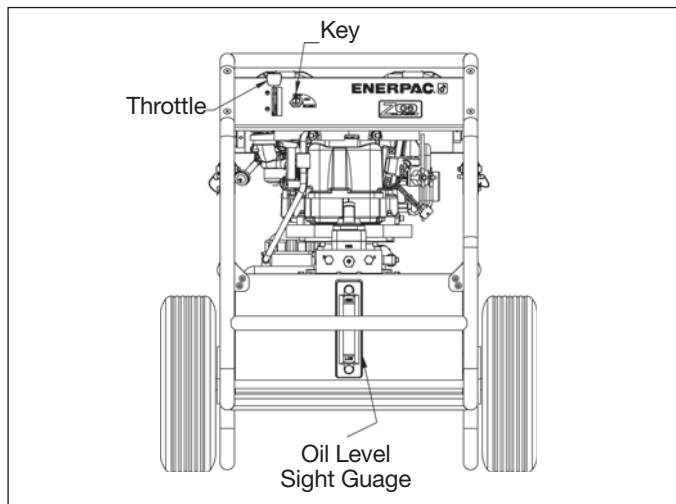

Figure 6

### 5.1 Manual Valve Operation

#### VM32 (See Fig. 7)

1. Advance
2. Retract (Neutral)

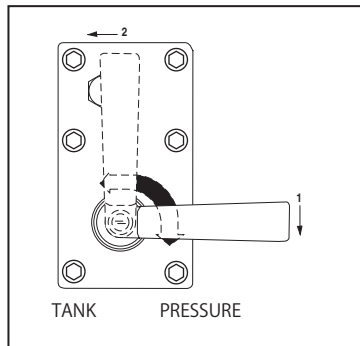

Figure 7

#### VM33, VM33L, VM43, VM43L (See Fig. 8)

1. Advance
2. Retract
3. Neutral

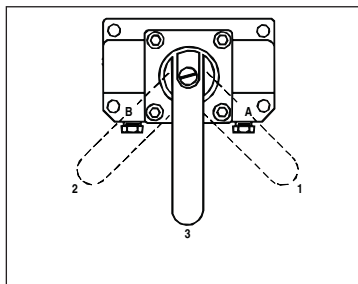

Figure 8

### 5.2 Relief Valve Adjustment

Z-Class pumps are equipped with one user adjustable relief valve (see Figure 9.) It can be adjusted as follows:

1. Install a gauge on the pump.
2. Start the pump to allow the oil to warm.
3. Loosen the set screw locking nut.

4. Shift the control valve and build pressure in the system. Using an Allen wrench, turn the set screw counter-clockwise to decrease pressure and clockwise to increase pressure.

**NOTE:** To get an accurate setting, decrease the pressure to a point below the final setting and then slowly increase the pressure until it reaches the final setting.

5. Tighten the locking nut when the desired pressure is set.
6. Shift the control valve to the neutral position, allowing the system pressure to return to 0 psi.
7. Recheck the final pressure setting by shifting the control valve and pressurizing the system.

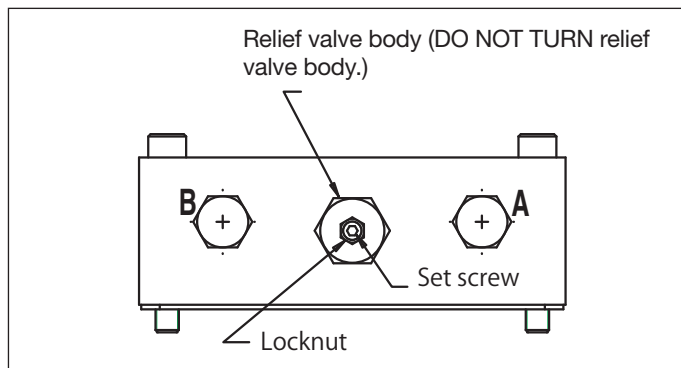

Figure 9

## 6.0 MAINTENANCE

Frequently inspect all system components for leaks or damage. Repair or replace damaged components.

### 6.1 Check Oil Level

Check the oil level of the pump prior to start-up, and add oil, if necessary, by removing the fill port cap. Always be sure cylinders are fully retracted before adding fluid to the reservoir. See Figure 2.

### 6.2 Change Oil and Clean Reservoir

Enerpac HF oil is a crisp blue color. Frequently check oil condition for contamination by comparing pump oil to new Enerpac oil. As a general rule, completely drain and clean the reservoir every 250 hours, or more frequently if used in dirty environments.

**NOTE:** This procedure requires that you remove the pump from the reservoir. Work on a clean bench and dispose of used oil according to local codes.

1. Unscrew the 13 bolts holding the coverplate to the reservoir and lift the pump unit out of the reservoir. Be careful not to damage the filter screen.
2. Pour all oil out of the reservoir.
3. Thoroughly clean the reservoir and reservoir magnet with a suitable cleaning agent.
4. Remove the pick-up filter screen for cleaning. (Do not pull on the screen or the bottom of the intake to avoid possible damage.) Clean the screen with solvent and a soft brush. Reinstall.
5. Reassemble the pump and reservoir, installing a new reservoir gasket.
6. Fill the reservoir with clean Enerpac hydraulic oil. The reservoir is full when oil level is in middle of the sight gauge (see figure 4).

### 6.3 Changing the Filter Element (optional)

A return line filter may be ordered as an accessory to the pump. The filter element should be replaced every 250 hours, or more frequently in dirty environments. The filter manifold is equipped with a 25 psi (1,7 bar) bypass to prevent over pressure rupture if filter plugging occurs. Filter element replacement part number is PF25.

### 6.4 Check Engine Operation

See the Honda or Briggs & Stratton Owner's Manual that was supplied with your pump. Follow the Maintenance Schedule to keep the engine in proper operating condition.

### 7.0 TROUBLE-SHOOTING (SEE TROUBLE-SHOOTING GUIDE)

Only qualified hydraulic technicians should service the pump or system components. A system failure may or may not be the result of a pump malfunction. To determine the cause of the problem, the complete system must be included in any diagnostic procedure.

The following information is intended to be used only as an aid in determining if a problem exists. For repair service, contact your local Authorized Enerpac Service Center.

Trouble-shooting Guide		
Problem	Possible Cause	Action
Engine will not start	See engine Owner's Manual	See section 5.0 Operation for details
Pump fails to build pressure or less than full pressure	Low oil level Relief valve set too low External system leak Internal leak in pump Internal leak in valve Internal leak in system component	Add oil per section 4.4 Adjust per section 5.2 Inspect and repair or replace See authorized service center See authorized service center See authorized service center
Pump builds full pressure, but load does not move	Load greater than cylinder capacity at full pressure Flow to cylinder blocked	Reduce load or add cylinder capacity Check hydraulic couplers for full engagement
Cylinder drifts back on its own	External system leak Internal leak in a system component Non-load holding valve used	Inspect all hydraulic connections and replace or repair See authorized service center See authorized service center
Single-acting cylinder will not return	No load on a "load return" cylinder Return flow restricted or blocked Valve malfunction Cylinder return spring broken	Add load Check couplers for full engagement See authorized service center See authorized service center
Double-acting cylinder will not return	Return flow restricted or blocked Valve malfunction	Check couplers for full engagement See authorized service center
Pump runs hot	Advance or retract flow restricted	Check couplers for full engagement