

**JDN OPERATION AND ASSEMBLY
INSTRUCTIONS AIR HOISTS
PROFi 1,5Ti, PROFi 3Ti/2**



Original Operation and
Assembly Instructions



J.D. NEUHAUS
powered by air!

Please enter the Serial No. of your JDN Air Hoist here.

This operation manual edition 12/2009, covers the following JDN Air Hoists:

PROFI 1,5 Ti

Fabr. No.

PROFI 3 Ti/2

Fabr. No.

It must be read carefully and in its entirety before operating any hoist. For hoists installed in trolleys, please also refer to the operation manual **JDN Trolleys**.



TABLE OF CONTENTS

SAFETY MEASURES

Organisational measures	5
Personnel safety	5
Preventing property damage	5

PRODUCT INFORMATION

About this operation manual	6
Warnings and symbols	6
Identification	7
Assembly overview	8
Product description	8
Explosion protection	9
Intended use	15
Emissions	16
Operating conditions	16
Energy requirements	17
Principle of operation of JDN air vane motors	18
Operation without chain box	19
Motor lubrication/operation with a service unit	19
CE marking / declaration of incorporation	19
Spare parts	19

TRANSPORT AND STORAGE

Safe transportation	20
Storage conditions	20

INITIAL OPERATION

Unpacking	21
Assembly	21
Installing the hoist	21
Connecting the controls	22
Replacing controls	25
Connecting to the main air supply	27
Lubricants	28
Inspection before initial operation	29

OPERATION

Rules for the safe operation of hoists	30
Controls	33
Emergency stop	35
Overload protection	36
Attaching the load	36
Lifting the load	37
Lowering the load	37

Detaching the load	37
Interrupting working	37

TAKING OUT OF OPERATION

Shutting down	38
Storage	38
Dismantling	38
Disposal	38

MAINTENANCE

Maintenance and inspection intervals	39
Cleaning and care	39
Spare parts	39
Lubricants	39
Inspection and repairs	39
Instructions concerning the "model for determining the actual operating time"	41
Lubricating chain	45
Checking braking function	45
Checking lifting and lowering limiters	46
Checking controls and emergency stop function	46
Checking direction of movement	46
Checking silencer for permeability	46
Service unit	47
Motor installation/checking brake linings and vanes/Motor lubrication	50
Removing and installing load sleeve, bottom block, clamp and buffer	53
Checking chain, chain sprocket and chain guides	55
Check dimensions	55
Checking axial play	57
Removing and installing chain	58
Replacing chain and chain sprocket	59
Overload protection	59

FAULTS, CAUSES AND REMEDIES

Troubleshooting guide	61
-----------------------	----

ACCESSORIES

Filter silencer	62
Booster unit	62
Chain box	63

APPENDIX

Technical data	64
Dimensions	65
Circuit diagrams	66



Please note:

Within the Federal Republic of Germany operators of air hoists must comply with trade association accident prevention regulations and rules, as well as state occupational safety regulations, in particular

- ▶ BGV A1 accident prevention regulations “Principles of Prevention”
- ▶ BGV D8 accident prevention regulations “Winches, Lifting and Pulling Devices”
- ▶ BGR 258 trade association regulations “Operation of Load-Carrying Devices Used with Lifting Equipment”

and, for air hoists installed in trolleys and for the operation of monorail hoists, additionally with

- ▶ BGV D6 “Accident Prevention Regulations for Cranes”

in the respective currently applicable version. Operators must also initiate the prescribed tests (see also “Principles for the Testing of Cranes” BGG 905 (ZH 1/27).

To document the tests we recommend the “Inspection log for cranes” BGG 943 (ZH 1/29) from the trade association.

When operating air hoists in areas with explosive atmospheres, the operator must comply with the relevant explosion protection regulations, e.g.

- ▶ BGR 104 “Explosion Protection Regulations” and
- ▶ BGR 132 “Prevention of Ignition Hazards due to Electrostatic Charges”

In all other countries, the operator must observe the relevant national regulations.

Special regulations may apply when incorporating air hoists into other installations or using air hoists under unusual conditions.

SAFETY MEASURES

ORGANISATIONAL MEASURES

JDN Hoists are designed in accordance with current technological standards and accepted safety practice. Nonetheless, the use of a hoist may be associated with risk of injury or fatality to the user or to third parties or with the risk of damage to the hoist or to other items, if safety rules are disregarded.

All personnel charged with operating hoists, must have read and understood the operation manual, especially the section entitled "Rules for the safe operation of hoists", before commencing work. This is particularly important for personnel who only occasionally operate the hoist, e.g. for maintenance or retrofitting work.

Operators of JDN Hoists are also under obligation to ensure safe and hazard-free operation. This can be achieved through the following measures:

- ▶ keep the operation manuals available at the hoist operating site,
- ▶ performing regular training,
- ▶ performing regular inspections (at least once annually),
- ▶ implement an inspection log and make regular entries,
- ▶ and regularly check personnel for safety and hazard awareness during work.

PERSONNEL SAFETY

Personnel who operate, maintain, inspect and perform setting-up work on the hoist must be properly trained or must receive an introduction from properly trained personnel before commencing work.

Due to their technical training and experience, properly trained personnel have adequate knowledge of hoists. They are sufficiently familiar with the relevant occupational safety and accident prevention regulations that they are able to assess the condition of hoists with regard to working safety.

- ▶ Follow the operating instructions for your workplace.
- ▶ Comply with the accident prevention regulations.
- ▶ Ensure that you are properly informed regarding working with hazardous materials.
- ▶ Follow the safety instructions set out in the operation manuals.

PREVENTING PROPERTY DAMAGE

Operators of JDN Hoists are under obligation to ensure that entries in the accompanying inspection log are made properly and regularly.

- ▶ Comply with the prescribed maintenance intervals.
- ▶ Only use JDN hoists for work which is described as intended use.
- ▶ Observe the operating conditions for JDN Hoists as described in this manual.



PRODUCT INFORMATION

ABOUT THIS OPERATION MANUAL

This operation manual is intended to help the operator familiarise himself with JDN Air Hoists and to take full advantage of their designated areas of application.

This operation manual contains important information for the safe, proper and efficient operation of JDN Air Hoists. Observance of the manual helps to avoid hazardous situations, to reduce repair costs and downtimes and to ensure the specified service life of the JDN Air Hoists.

WARNINGS AND SYMBOLS

Safety warnings in this operation manual are classified in three categories:



DANGER!

Safety warnings which, if not followed, can result in danger to life and limb, are indicated by this symbol. The symbol indicates an immediate danger. The possible consequences of non-observance may be death or severe injuries.



CAUTION!

This symbol indicates potentially hazardous situations. Failure to observe may result in minor injuries.



ATTENTION!

This symbol indicates that failure to follow the relevant instructions may result in damage to the device or other items.



IDENTIFICATION

The nameplate mounted on the housing cover identifies the type of JDN Air Hoist and contains all important rating data.

If you have any questions concerning operation of JDN Air Hoists, which are not addressed in this operation manual, please contact us at the following address:

J.D. NEUHAUS GMBH & CO. KG
 Windenstraße 2-4
 D-58455 Witten-Heven

Phone 023 02/208-0
 Fax 023 02/208-286
 www.jdn.de
 e-mail: info@jdn.de

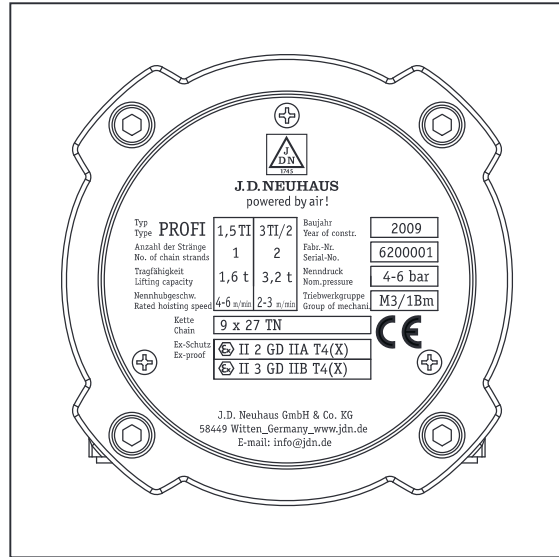

Example of nameplate on housing cover



ASSEMBLY OVERVIEW

PROFI TI series air hoists consist of the following assemblies:

- 1 Gearbox with chain sprocket and overload protection
- 2 Centre section
- 3 Motor with integral brake function
- 4 Controls with main air EMERGENCY STOP
- 5 Chain
- 6 Load hook with load sleeve or bottom block and buffer

PRODUCT DESCRIPTION

The PROFI TI series JDN Air Hoists described here are designed for load-carrying capacities of 1.6 t (PROFI 1.5 TI) and 3.2 t (PROFI 3 TI/2). Various control devices are available for the different requirements.

The air vane motor of the hoist, together with the appropriate controls, is capable of sensitive movement. This enables precise positioning of the load.

PROFI TI series JDN Air Hoists conform to driving mechanism classification in the following table:

	Hoist	Chain
1.5 TI	M3 / 1 Bm	M3/ 1 Bm
3 TI/2	M3 / 1 Bm	M3/ 1 Bm

ISO 4301 / FEM 9.5.11

PROFI TI JDN Air Hoists feature rotors with grease chambers. These contain JDN high-performance grease which enables operation with oil-free compressed air. It remains effective for an operating period of approx. 250 hours and should be renewed when required, but after five years at the latest (see **Motor lubrication**, page 19). Additional lubrication with oil-bearing compressed air by means of a service unit with oiler is possible.

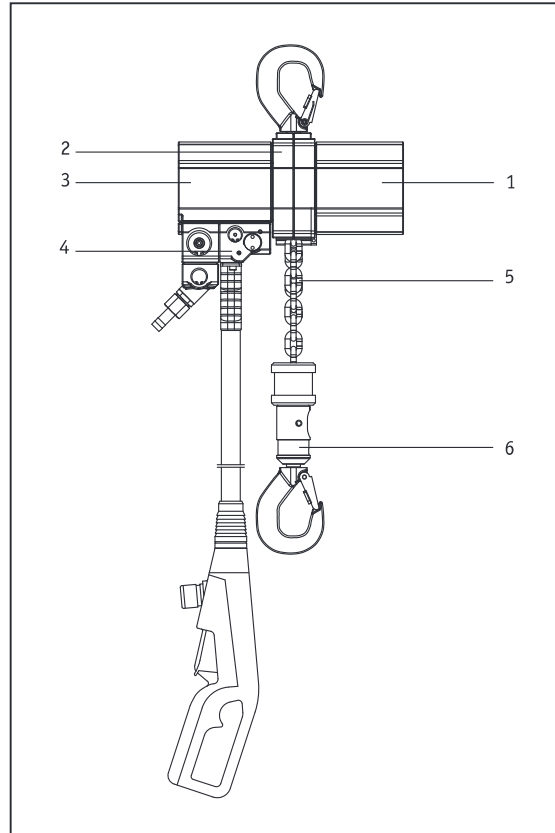

PROFI TI series JDN Air Hoist

EXPLOSION PROTECTION

The basis for the following information is an expert statement by the DMT Gas & Fire Division on the use of JDN Hoists, Trolleys and Crane Systems in potentially explosive areas and is based on European Directive 94/9/EC¹ ("ATEX 100a"). DMT is accredited with the testing of devices and protection systems for intended use in explosion-hazardous areas.

BASIC EXPLOSION PROTECTION FOR THE STANDARD VERSIONS

Standard version JDN air hoists are category 2 devices (Guideline 94/9/EC, DIN EN 1127-1²), for use in zone 1 and 2 for gases of explosion group IIA. (Also see IEC 60079-12³ and IEC 60079-20⁴). These devices are also suitable for use in zone 2, in the presence of gases of explosion group IIB, provided that the substances hydrogen sulphide and ethylene oxide can be excluded and additionally in zones 21 and 22 for dusts with glow temperatures above 210° C or ignition temperatures above 202° C, provided that no light metal or other impact-sensitive dusts are present.

These devices are designated by:

⊕ II 2 GD IIA T4(X)/II 3 GD IIB T4(X) Additional designation "X" see page 10.

JDN HOISTS

"WITH INCREASED SPARK PROTECTION"

JDN hoists of the version "with increased spark protection" (FS) satisfy additional explosion protection requirements. With the exception of carbon disulphide (temperature class T6), they can be used in the presence of all gases in zones 1 and 2 and dusts with glow temperatures above 210° or ignition temperatures above 202° in zones 21 and 22, and can be marked

⊕ II 2 GD IIC T4(X) for installation in a trolley, depending upon the trolley version (see below), but also with ⊕ II 2 GD IIB T4(X). For further operating conditions, see Instructions for safe operation (Notes **D** and **E**).

JDN HOISTS FOR USE IN THE PRESENCE OF TEMPERATURE CLASS T6 GASES OR EXTREMELY EXPLOSIVE DUSTS

Following separate tests, especially with regard to ambient temperatures and type of operation, use in the presence of carbon disulphide or dusts with particularly low glow or ignition temperatures may be possible with designation ⊕ II 2 GD IIC T6(X), which includes the additional designation "X" for special conditions (see Additional designation "X"). Please contact us with regard to these requirements.

STANDARD JDN TROLLEY AND CRANE RUNNING GEAR

JDN trolleys and cranes can be used in zone 2 with standard running wheels (made of steel or cast metal) with all dusts and the presence of gases up to explosion group IIC. Due to the low running speeds, the possible friction velocities on the running wheels are less than 1 m/s, which means that standard running wheels can also be used in zone 1 up to explosion group IIB. The highest possible designation for these devices is:

⊕ II 2 GD IIB T4(X)/II 3 GD IIC T4(X). Depending on the hoist version, it may have the designations

⊕ II 2 GD IIA T4(X)/II 3 GD IIB T4(X) or

⊕ II 2 GD IIB T4(X).

JDN TROLLEY AND CRANE RUNNING GEAR "WITH INCREASED SPARK PROTECTION"

For use in zone 1 in the presence of gases in explosion group IIC, bronzed running wheels or running wheels made of bronze are also used. The highest possible designation for this version (FSR) is

⊕ II 2 GD IIC T4(X) (the same as for JDN hoists "with increased spark protection").

JDN TROLLEY AND CRANE RUNNING GEAR FOR USE IN THE PRESENCE OF TEMPERATURE CLASS T6 GASES OR DUSTS

As is the case with JDN hoists "with increased spark protection", temperature class T6 is also possible here in the case of a special investigation of applicability, permitting the highest possible designation for standard wheels ⊕ II 2 GD IIB T6(X)/II 3 GD IIC T6(X)



and for bronzed or bronze wheels

⊕ II 2 GD IIC T6(X), i.e. each including the additional designation "X" for special conditions.

GENERAL NOTE ON DESIGNATION

The highest possible respective designations for lifting equipment and running gear are usually replaced by a designation which corresponds to the normal assembly of a compact complete device (trolley or crane system).

ADDITIONAL DESIGNATION "X"

This designation refers to explosion protection details in the operation manual.

⊕ II 2 GD IIA T4(X)/II 3 GD IIB T4(X) or

⊕ II 3 GD IIA T4(X):

This designation does not permit use in the presence of the extremely flammable substances hydrogen sulphide and ethylene oxide or in the presence of light metal or other impact-sensitive dusts, or in the presence of dusts with glow temperatures below 210° C or ignition temperatures below 202° C. The permissible ambient temperature range (Ta) extends from - 20° C to + 70° C.

⊕ II 2 GD IIC T4(X) or ⊕ II 2 GD IIB T4(X):

The permissible ambient temperature range (Ta) extends from - 20° C to + 70° C.

⊕ ... II C T6(X):

This designation permits use in the presence of carbon disulphide or other temperature class T6 substances only under special conditions, which have been agreed with the manufacturer and which are described in the crane documentation and which stipulate the maximum surface temperatures for the device.

USE IN MINING APPLICATIONS

Standard versions of JDN hoists, trolleys and crane systems may generally also be used for underground mining operations as well as for the associated surface facilities, which are hazardous due to firedamp and/or combustible dusts. Within this equipment group I they belong to category M2. They constitute devices which can be switched off in cases where an explosive atmosphere forms. They are equipped with protective measures offering a high degree of safety. The protective measures with which products of this category are equipped provide the necessary degree of safety for normal operation as well as operation under difficult conditions, in particular rough treatment and changing environmental influences. For other difficult

conditions in addition to explosion protection prevailing with regard to the general handling of the devices in mining applications, special mining hoists are available from J. D. NEUHAUS. The maximum permissible temperature of 150° C in accordance with EN 13463-1⁵ for coal dust atmospheres is not reached. For mining applications, the relevant designation for hoists, trolleys and crane systems is ⊕ I M2.

LOAD CHAIN

In order to guarantee the required degree of earthing, rusty chains must no longer be used in zones 1 and 21. This is due to the fact that, depending upon the degree of corrosion, the leakage capability of the chain may be impaired to a level that is no longer adequate.

COMPRESSED AIR HOSES

In zone 1, compressed air hoses must have a sufficiently low surface resistance of less than 10⁹ Ω in order to prevent electrostatic ignition hazards. Otherwise (resistance >10⁹ Ω), for explosion groups I, IIA and IIB ∅ ≤ the hoses must be 30 mm and for explosion group IIC ∅ ≤ 20 mm, or proof must be provided that they cannot become dangerously charged.

MATERIALS FOR FRICTION AND IMPACT HAZARDS

Friction and impacts can give rise to individual sparks presenting a danger of ignition in the presence of explosion group IIC gases, hydrogen sulphide, ethylene oxide, or light-metal or other impact-sensitive dusts. Accordingly, spark formation caused by mechanical influences must be prevented.

The chain and load must always be moved in such a way that sliding and/or frictional contact with other plants or components is excluded. If circumstances do not permit this, it is necessary to ensure an absence of explosive atmospheres during operation.

Impacts between particular materials result in an increased ignition hazard. This does not apply to corrosion-resistant steel or cast iron against aluminium, magnesium or corresponding alloys. This applies especially in the presence of rust or rust film. Rust (also rust film) formation is possible, especially on the chain and on the load hook, at the friction points. The following holds true for all zones: For the intended use of hoists it must be ensured, that no rust is present at the above-mentioned friction



points and that material combinations of the above-named light metals with steel (exception: stainless steel) are not used in the working area of the hoists, at potential friction, impact or sliding points. It is thus possible to exclude sparking due to mechanical influences with these material combinations.

The external housing of the service units is made of aluminium. Therefore the installation position is to be selected so as to ensure that there is no risk from impact sparks.

EARTHING

Electrostatic ignition hazards can be prevented by means of safe earthing. In zones 1 and 21, earthing of the hoists is required. This must be achieved via the load hook or the load eyes if the lifting equipment is connected to correspondingly earthed parts (earth leakage resistance less than $10^6 \Omega$). This also applies to operation with trolleys or cranes. Their tracks must be earthed on site. Running wheels and rail surfaces must never be painted, as this can result in unacceptably high earth leakage resistance values.

Earthing of the load hook is via the chain (see also **Load chain**, page 10).

Loads must be earthed during transportation. A separate earth is required, for example, when using non-conducting sling gear.

CLEANING PLASTIC SURFACES

Where JDN Air Hoists or JDN Air Winches feature plastic parts, these surfaces must only be cleaned using a damp cloth (cleaning cloth with water). This reduces electrostatic charging that can arise due to mechanical friction at the plastic surface.



DANGER!

Electrostatic charging may occur at the plastic surfaces, potentially leading to electrostatic discharge that can ignite gases and air mixtures.

ACETYLENE AND COPPER

When operating JDN products in explosion-hazardous areas, in which an acetylene-containing atmosphere can occur, it must be ensured that copper-plated parts are kept dry in order to exclude the possibility of oxidation of the metallic copper and the formation of an aqueous phase, which is capable of reacting with acetylene and which can result in an explosion hazard.



EXPLOSION GROUPS AND TEMPERATURE CLASSES OF THE MOST IMPORTANT GASES AND VAPOURS (-SELECTION-)
(in accordance with DIN VDE 0165⁶, Redeker⁷, Nabert, Schön⁸, IEC 60079-12³ and IEC 60079-20⁴)

Explosion protection group	Temperature class					
	T1	T2	T3	T4	T5	T6
	Ignition temperature					
	> 450° C	450-300° C	300-200° C	200-135° C	135-100° C	100-85° C
Maximum permissible surface temperature of operating facilities						
	450° C	300° C	200° C	135° C	100° C	85° C
II A	Acetone Ammonia Aniline Benzene Chlorbenzene 1.2-Dichlorbenzene Acetic acid Ethane Ethyl acetate (ethyl bromide) Ethyl chloride (carbon monoxide) o-Cresol Methane Methyl acetate Methyl alcohol* ¹ Methyl bromide Methyl chloride Methylene chloride Naphthalene (nitrobenzene) Phenol Propane Toluene o-Xylene	(ethyl alcohol) (ethylene glycol) i-Amyl acetate n-Butane n-Butyl alcohol 1-Butylene 1.2-Dichlorethane Di-i-propyl ether Natural gas Acetic anhydride n-Propyl acetate (n-Propyl alcohol) i-Propyl alcohol Vinyl chloride	n-Amyl alcohol Petrol (fuel) Diesel Heating oil n-Hexane Jet fuels	Acetaldehyde		
II B	Hydrocyanic acid (ethyl bromide) (carbon monoxide) (nitrobenzene) Town gas	Butadiene-1.3 Dioxane-1.4 Divinyl ether (ethyl alcohol) Ethylene (ethylene glycol) **Ethylene oxide Isoprene (n-Propyl alcohol)	Dimethyl ether **Hydrogen sulphide	Ethyl ether Ether Anaesthetic ether Diethyl ether		
II C	**Hydrogen	**Acetylene				**Carbon disulphide

(): The measured values for the substances placed in brackets are close to the limit or the next group or class when classified in the explosion groups or temperature classes. For this reason, they have been included in both.

** : Extremely flammable substances (cf. additional designation "X")

*1 (Methanol = Methyl alcohol)

**DECISION CRITERIA FOR SELECTING THE CORRECT JDN HOISTS
IN EXPLOSION-HAZARDOUS AREAS**

Explosion groups for gases and vapours (cf. explosion group and temperature classes for the most important gases and vapours)	Zone	Version*1		Operation*2			
		Manufacturer responsibility		Operator responsibility			
II A	2	A			E		
	1	A			E		
II B (X) except hydrogen sulphide, ethylene oxide (highly flammable)	2	A			E		
	1	A	SP		E		
II B	2	A	SP		D	E	
	1	A	SP		D	E	
II C/ T4	2	A	SP		D	E	
	1	A	SP	FSR	D	E	
II C/ T6(X)	2	A	SP		D	E	T
	1	A	SP	FSR	D	E	T
Potentially explosive dusts	Zone	Version*1		Operation*2			
Usual industrial dusts	22	A			E		
	21	A			E		
Light metal or impact-sensitive dusts	22	A	SP		D	E	
	21	A	SP		D	E	

***1: Version features (under the responsibility of the manufacturer):**

A: The chain is made of zinc-plated steel; metal controls are conductively connected to the hoist. This is part of the standard equipment. For technological reasons, a zinc-plated version of chain size 31.5 x 90 is not available. This is only used for the extremely slow-running chain drives of large hoists, so that the sliding velocity for potential friction points between the chain and the surroundings remains well below 1 m/s.

SP: Hoists "with increased spark protection":

Copper-plated load hook and bottom flange with brass safety catch.

FSR: Running gear "with increased spark protection":

Running wheels for trolleys and cranes are made of bronze.

***2: Instructions for safe operation (operator's responsibility):**

D : Ignition hazards are not to be expected if hoists or cranes are used in the normal manner. Friction and impacts in the working area of the chain, not resulting from intended use of the hoist or crane and which result in sparking, must be excluded, or an absence of gas in the operating area must be ensured. This means, for example, that the chain, the bottom block and the load hook must be prevented from swinging against surrounding objects or that a gas-free environment must be ensured.

E : Friction, impact and sliding points involving combinations of light metal and steel or cast iron must not be present in the hoist's operating area.

T : Ambient temperature and the type of operation must be examined separately.



**TEMPERATURE LIMITS
FOR EXPLOSION-HAZARDOUS DUSTS**

In areas that are potentially explosive due to combustible dusts, the surface temperature must not exceed two-thirds of the ignition temperature in °C of the dust/air mixture. The temperatures of surfaces on which hazardous deposits of combustible dusts can be formed, must not exceed the glow temperature of the relevant dust minus 75°K. Greater safety margins are required if the thickness of the dust layer exceeds 5 mm.

The corresponding surface temperatures can be derived from the lowest values for glow and ignition temperatures of dusts specified in the HVBG/BIA Report 12/97¹⁰ "Combustion and explosion characteristics of dusts":

Synthetic rubber, soot-containing:

Glow temperature $220^{\circ}\text{C} - 75^{\circ}\text{C} = 145^{\circ}\text{C}$ max.
permissible surface temperature

Stearic acid:

Ignition temperature $190^{\circ}\text{C} \times 2/3 = 126^{\circ}\text{C}$ max.
permissible surface temperature

**PLEASE ALSO OBSERVE YOUR
CORRESPONDING NATIONAL
REGULATIONS.**

-
- ¹ Guideline 94/9/EC of the European Parliament and the Council dated 23 March 1994 on the adaptation of the laws of the Member States concerning equipment and protective systems intended for use in potentially explosive atmospheres
 - ² DIN EN 1127-1: Explosive atmospheres - Explosion prevention and protection - Part 1: Basic concepts and methodology, 1997-10
 - ³ IEC 60079-12: Electrical apparatus for explosive gas atmospheres, Part 12: Classification of mixtures of gases and vapours with air according to their maximum experimental safe gaps and minimum igniting currents, 1978.
 - ⁴ IEC 60079-20: Electrical apparatus for explosive gas atmospheres, Part 20: Data for flammable gases and vapours relating to the use of electric apparatus, 1996-10.
 - ⁵ EN 13463-1: Non-electrical devices intended for use in explosive areas - Part 1: Basic methodology and requirements, 07/2009
 - ⁶ DIN VDE 0165: Installation of electrical systems in areas with explosion hazard, 1991
 - ⁷ Redeker, Schön: 6. Supplement to safety-related characteristic values for flammable gases and vapours, 1990
 - ⁸ Nabert, Schön: Safety-related characteristic values for flammable gases and vapours, 2nd edition, 1978
 - ⁹ DIN EN 50014 (VDE 0170/0171 part 1): 2000-02 Electrical apparatus for use in explosion hazardous areas: General provisions
 - ¹⁰ HVBG/BIA report 12/97: Central association of German employer's liability associations/trade association institute for industrial safety

INTENDED USE

JDN Air Hoists are designed for lifting and lowering loads within the specified load-carrying capacities, with a vertically-arranged chain. JDN Air Hoists from the PROFI 1.5 TI and 3 TI/2 ranges are also suitable for pulling loads horizontally. In exceptional circumstances, the lifting of personnel-carrying equipment is also permitted under certain conditions. Please also observe the individual national regulations. In combination with trolleys, JDN Air Hoists are also suitable for the floorless horizontal movement of loads.

Any other use or use outside these stipulations is deemed to be impermissible. Oblique pulling, see **Operation** section, page 29. J.D. NEUHAUS GMBH & CO.KG cannot be held liable for any resulting damage. The entire risk is borne by the user (see also section **Rules for safe operation of hoists**, page 30).

Intended use also includes observance of the operation manuals and compliance with the inspection and maintenance conditions.



EMISSIONS

The noise emission data can be found in the **Technical data** table, pages 64.

The noise pressure level of the measurement area at a distance of 1 m from the machine surface was measured in accordance with DIN 45 635, Part 20, at the operating air pressure specified by us. In the hall, the noise pressure level drops by approx. 3 dB (A) every time the distance is doubled.

If the device is operated with motor oil lubrication, small amounts of lubrication oil will be released into the environment with the outlet air.

Oil emissions can be prevented by using a filter silencer (see **Filter silencer** section, page 62). This also results in a reduction of the noise emission values.

OPERATING CONDITIONS

JDN Air Hoists are extremely robust and require little maintenance. They are suitable for use in explosion-hazardous areas, as well as in areas with increased concentrations of soot and dust, high humidity and at ambient temperatures from - 20° C to approx. + 70° C if they are not heated above this level due to external influences. The thermal endurance of chains and hooks is + 150° C.



CAUTION!

When touching metallic hand controls which are colder than 0° C, skin could freeze within a few seconds, and at temperatures above 43° C, burns may occur. As a protective measure, please wear suitable gloves.

For stationary outdoor operation, hoists must be protected against weathering and the maintenance intervals must be shortened.

Depending upon the version, JDN Air Hoists must be operated at a system pressure of at least 4 bar (see information on the nameplate). If the system pressure is too low, important functions of the hoist will be impaired:

- ▶ The brake will drag and is thus subject to a high degree of wear. An impermissibly high degree of warming could take place.
- ▶ The controls become noticeably less sensitive.



DANGER!

Warning against excessive system pressures

Operating with excessive system pressures results in danger due to overloading. Therefore, the pressure must be limited to that specified on the nameplate.

JDN Air Hoists must be operated with a sufficiently clean and dry air supply. The air supply must fulfil the following quality requirements:

- ▶ Particle size less than 40 µm
- ▶ Particle density less than 10 mg/m³
(corresponds to Class 7 in accordance with ISO 8573-1:2001)

In order to provide adequate compressed air quality, operation with a service unit is recommended. Usually, an oiler is not required in the service unit, as the motor is provided with internal permanent lubrication.

- ▶ Pressure dew point at least 10° C below the lowest expected ambient temperature

Do not operate JDN Air Hoists with other gases.

With moist air and ambient temperatures at or below 0° C, there is a danger of icing in the motor.

Icing can be prevented by:

- ▶ the use of an upstream air dryer or using a service unit with oiler,
- ▶ adding anti-icing agent to the lubrication oil (depending upon moisture content of compressed air),
- ▶ or using compressed air oil (Part No. 11900) with anti-icing agent for relevant temperatures.

In case your JDN Air Hoist is operated in combination with a trolley, please read also the trolley operation manual and the relevant accident-prevention regulations for operation with trolleys.



ENERGY REQUIREMENTS

For air pressure, air quantity and connections, see the **Technical data** table in the hoist operation manual concerned.

AIR PRESSURE CONDITIONS IN OPERATION

The system pressure in the air line must correspond to the nominal pressure. Higher pressures must be reduced.

After switching on, the nominal pressure p_1 drops to the actual pressure p_2 .

The value of the actual pressure p_2 at which the hoist is operated, depends upon

- ▶ the weight of the load and
- ▶ the direction of movement of the load.

When lifting the nominal load (load-carrying capacity), the actual pressure p_2 must not fall below a value of 10% below the specified nominal pressure of the hoist.

Example:

A hoist with a nominal pressure of 6 bar lifts its nominal load at the specified lifting speed, at an actual pressure of 5.4 bar.

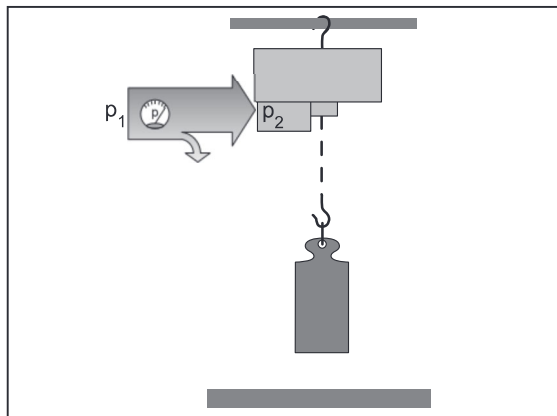

The value of the actual pressure depends upon ...

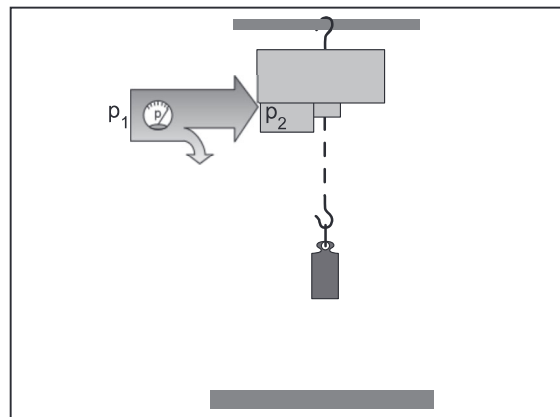

... the weight of the load ...

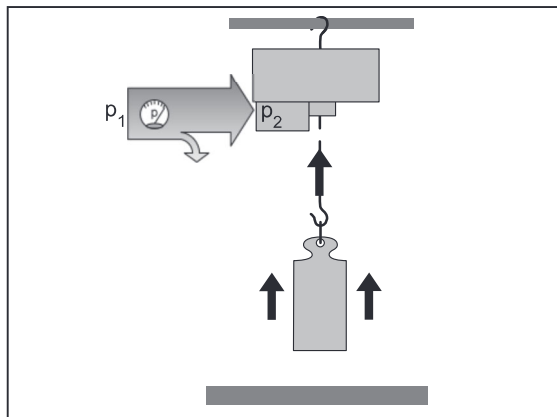

... and the direction of movement of the load.

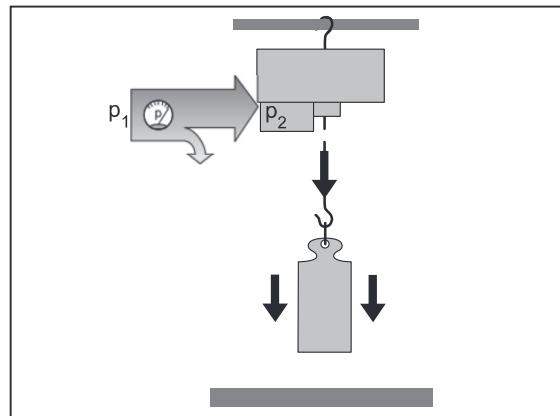

**PRINCIPLE OF OPERATION OF
JDN AIR VANE MOTORS**

The vane motor consists of a cylinder liner **1** with two side bearing plates and an internal rotor **2**.

The rotor is mounted eccentrically in the cylinder liner and is provided with slots **3** for installation of the vanes **4**.

The vanes can move freely and make contact with the inner wall **5** of the cylinder liner. Each chamber **6** is formed by two vanes.

Due to the incoming compressed air, a greater force is created at the leading, larger vane surface **4.1** than that at the trailing, smaller vane surface **4.2**. The difference in force generates the rotor torque.

As the chamber passes the outlet aperture **7**, the compressed air can escape.

Lubricant chambers **8** are provided between the vane slots of the rotor. They ensure continual motor lubrication.

The arrows in the illustration indicate the direction of rotation of the rotor and the corresponding path of the compressed air.

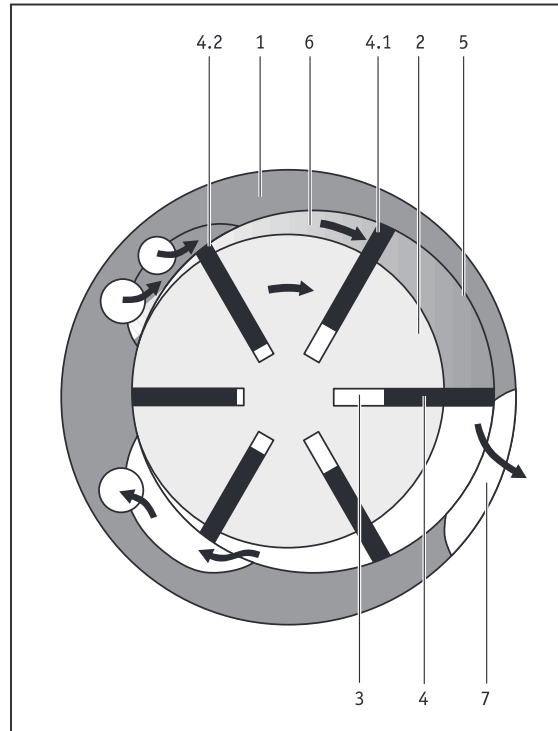

OPERATION WITHOUT CHAIN BOX



DANGER!

If JDN Air Hoists are operated without a chain box it must be ensured that the idle chain (unloaded chain end) running up or down at the chain sprocket, does not present a hazard, e.g. due to catching, impacting or falling.

Danger due to falling chain can also arise, if the idle chain is first deposited on a load with a large surface and then slides off and drops.

SPARE PARTS

Only use **original JDN spare parts**. J.D. NEUHAUS GMBH & CO. KG accepts no liability for the use of non-original components and/or modifications by unauthorised persons.

MOTOR LUBRICATION/OPERATION WITH A SERVICE UNIT

JDN air hoists are provided with motor lubrication, which must be renewed when required, but every 5 years at the latest.

Therefore, the service unit for filtration and pressure-regulation of the compressed air can be installed without an oiler. If required, the service unit is also available with an oiler. Synthetic lubricants must not be used when operating with a service unit. Alcohols are not permitted for use as anti-icing agents.



ATTENTION!

During operation with oil, the grease chambers for motor lubrication are emptied more quickly.

CE MARKING/DECLARATION OF INCORPORATION

Only hoists for which EC conformity in accordance with EC Machinery Directive 2006/42/EC has been declared may be operated within the EU.

In the case of a CE designation, only the EC conformity declaration provides information on which EC directive has been met.



TRANSPORT AND STORAGE

SAFE TRANSPORTATION

If you wish to transport your JDN Air Hoist to another site, please observe the following points:

- ▶ Carefully dismount trolley (if fitted).
- ▶ Set the entire hoist down carefully; do not allow it to drop. For weights see **Technical data**, page 64.
- ▶ Lay control and supply hoses together in such a way that they are not kinked.
- ▶ Please ensure that the controls are not damaged.
Risk of malfunction.
- ▶ Draw in the hoist's chain in such a way that loops cannot form and the chain cannot become twisted.
- ▶ Secure the chain.

STORAGE CONDITIONS

BREAKS IN OPERATION

- ▶ In the case of longer operational breaks, coat the chain and hook with a light oil film.
- ▶ Motor conservation

If the motor lubrication is not renewed after the specified intervals, the motor must be conserved. For this purpose, use a non-resinous and non-sticky conserving oil with conserving protection duration, which corresponds to the length of the planned operational break.

STORAGE

- ▶ Close off the air supply hose connection using adhesive tape or a suitable cap in order to prevent dirt ingress.
- ▶ Protect connection for the air supply hose against damage.
- ▶ Store your JDN Air Hoist in a clean and dry place.



INITIAL OPERATION

UNPACKING



CAUTION!

When unpacking, take account of the weight of the hoist. See **Technical data**, page 64.



ATTENTION!

Do not bend the control lines. Kinked control lines can result in malfunctions.

- ▶ Keep the accompanying documents in the place provided, near the operating site.
- ▶ Lift the hoist carefully out of the packaging.
- ▶ Dispose of packaging in the local recycling system.

ASSEMBLY

JDN Air Hoists are usually delivered pre-assembled.

If not, first read the following sections:

- ▶ **Connecting the controls**, page 22
- ▶ **Removing and installing chain**, page 58
- ▶ **Chain box**, page 63

In the event that the chain is included unattached, a short auxiliary chain is drawn into the hoist. In order to draw in the chain, the hoist must be connected to the main air supply and must be ready for operation.

PRIOR TO INITIAL OPERATION, THE CHAIN MUST BE LUBRICATED (SEE SECTION LUBRICATING THE CHAIN, PAGE 45).

INSTALLING THE HOIST

Mounting the trolley, see trolley operation manual.



DANGER!

JDN Air Hoists must only be installed by qualified personnel. Faulty installation can lead to serious accidents.



DANGER!

The attachment points for JDN Air Hoists must be able to safely withstand the expected forces. Ensure that your JDN Air Hoist is capable of alignment under load, otherwise inadmissible additional stresses may occur.



DANGER!

The supporting structure of the air hoist must form a rigid mounting. Vibration damages the chain and can lead to chain fracture. Furthermore, external vibration must on no account be transmitted to the hoist (lifting gear). (e.g. from the suspended load).

- ▶ Provide a suitable working platform.
- ▶ Attach the hoist at the suspension hook (or suspension eye) to running gear or stationary fixing.
- ▶ Ensure that the hook safety catch closes automatically.

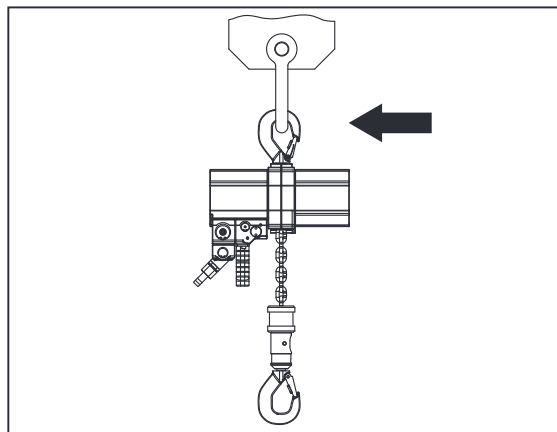

Attach the hoist securely at the suspension hook or suspension eye.



CONNECTING THE CONTROLS

CONNECTING THE ROPE CONTROL

- ▶ Knot both control ropes at the ends of the control lever.
- ▶ Knot the green pin into the rope which activates "lift" mode, with the pointed end upwards (see also illustration **Rope control**, page 22).
- ▶ Knot the yellow pin into the rope which activates "lower" mode, with the pointed end upwards.
- ▶ Knot the handle into the rope so that the arrow markings correspond to the actual direction of movement.

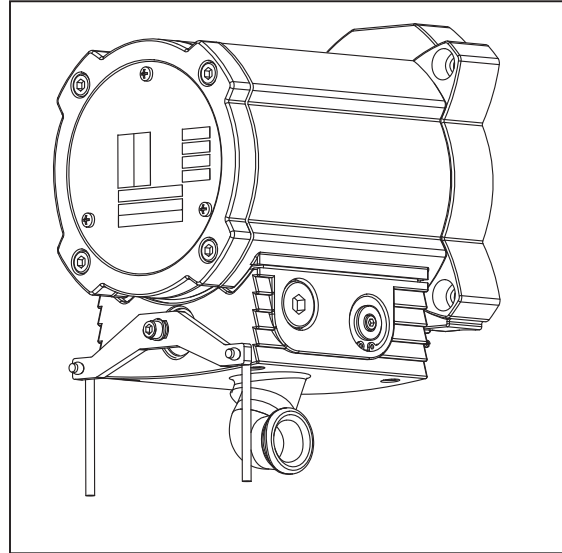

Rope control, motor side

CONNECTING THE E-CONTROLS

Pushbutton valve (hand control)

- ▶ Guide the strain-relief cable through the eye on the pushbutton valve and secure using the cable clamp.
- ▶ Push the one-ear clamps onto the hose ends.
- ▶ Attach the hoses to the hose nipples.
- ▶ The one-ear hose clamp must lie in the middle of the hose nipple clamping range. The best clamping characteristics are achieved in this range.

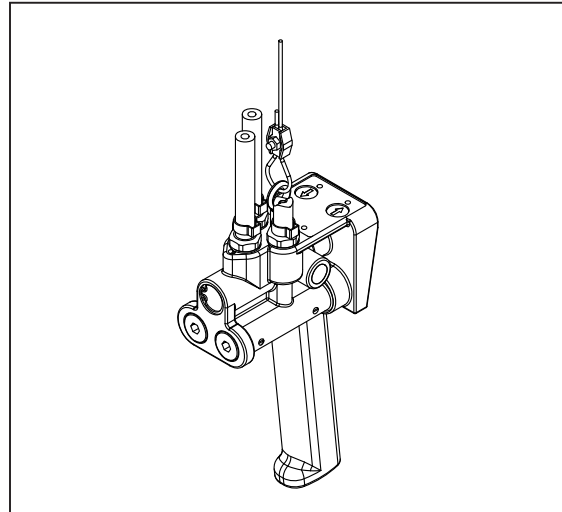

Pushbutton valve with nipple and rope with designation lift and lower

- Secure the hoses using the one-ear hose clamps and crimping tool.



ATTENTION!

To ensure perfect sealing, the “ear” must be fully closed on installation.

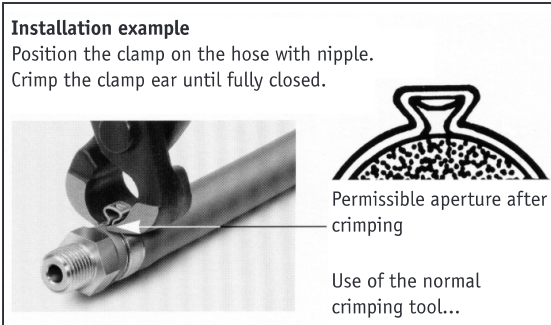

Pinched one-ear clamp and crimping tool

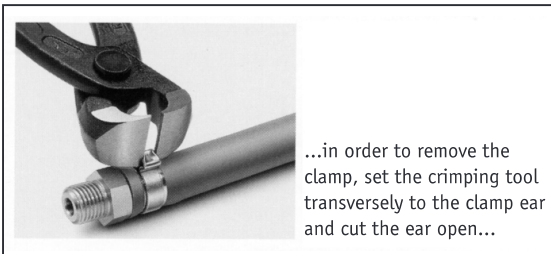

Removal

- The bellows must be pulled over the other end of the hose bundle including the strain-relief cable (coat hose bundle with oil for ease of fitting). Pull the bellows back far enough to permit further installation. Push the one-ear clamps onto the free ends of the hoses.

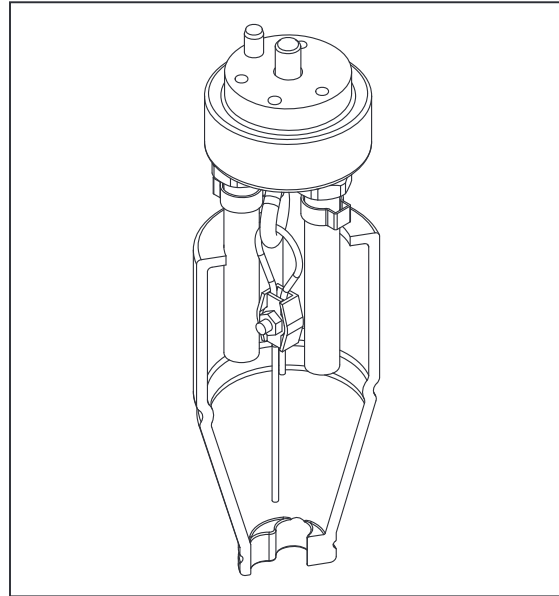

Illustration of bellows with hoses and strain-relief rope



Control valve (on motor)

Note: In order to connect the hoses to the control valve, we recommend removal of the hose adapter.

- ▶ Remove the hose adapter (secured via central bolt).
- ▶ Attach the hoses to the corresponding nipples (see designation in illustration)
- ▶ Secure the hoses using the one-ear hose clamps and crimping tool.
- ▶ Secure the strain-relief cable.



ATTENTION!

The strain-relief rope must be installed with the correct length in order to prevent loading of the hoses.

- ▶ Pull the bellows over the hose adapter. The upper collar of the bellows fits into the recess of the hose adapter.
- ▶ In order to secure the hose adapter to the control valve, a long A/F 6 socket spanner must be guided between the three hoses, through the middle of the bellows and inserted into the hexagon socket of the bolt.

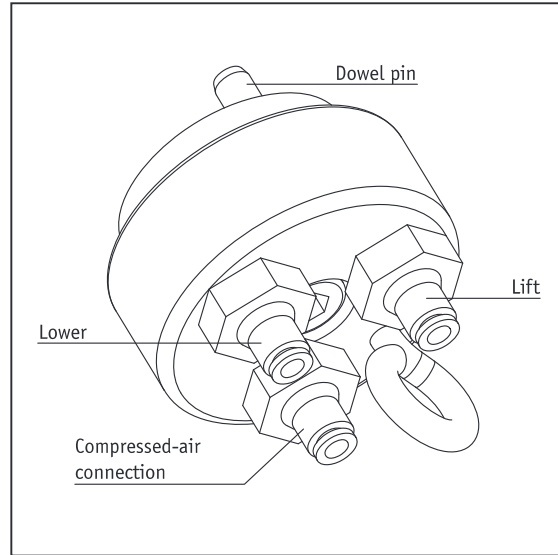

Hose adapter with nipples designation lift, lower

CONNECTING F-CONTROLS

Pull the bellows over the hose bundle for F-control. For F-control for lifting and lowering only, remove approx. 80 mm of hose bundle protective sheathing; for F-controls with additional functions (trolley/crane movement) remove approx. 160 mm from end of protective sheathing.

Pull the strain-relief cables through the eye bolt and secure using cable clamps.

Insert the control hoses: See illustration above

Compressed air with hose designation 1 or colour: white

Direction of movement "lift"
with hose designation 2 or colour: green

Direction of movement "lower"
with hose designation 3 or colour: red

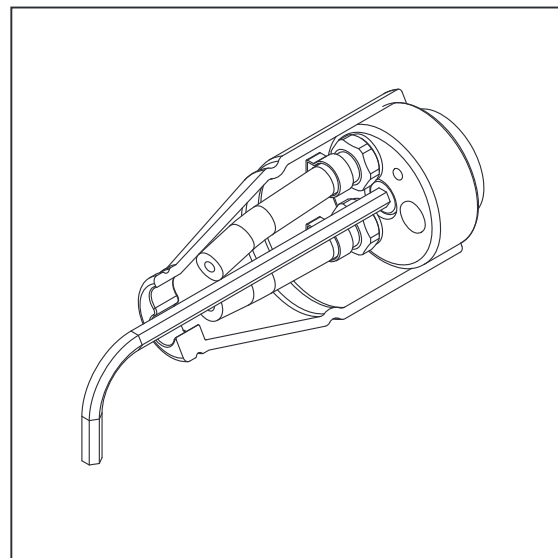

Bellows with A/F 6 socket spanner



The control hoses for the drive motors (trolley/crane movement) must be extended, outside of the bellows, by means of plug-in connectors and additional control hoses.

Connection see "Trolley" operation manual.



ATTENTION!

The control hoses must not be subject to tensile load; adjust the strain-relief cables accordingly.

Pull the bellows over the hose adapter and secure via the central bolt (see illustration on page 24, bottom).

CONNECTING FI-CONTROLS

Pull the bellows over the hose bundle for F-control. Remove approx. 80 mm of hose bundle protective sheathing.

With this type of control, strain-relief of the hand controls takes place via the protective sleeve of the hose bundle. For this purpose, the protective sleeve is pushed onto the hose carrier and is secured using a one-ear clamp.

Installation facilitation: Heat the protective sleeve (hose sheathing) with a hot-air gun and grease the hose carrier.

Slightly bend open the ring of the eye bolt in order to attach the hose carrier.

Close the ring again to prevent detaching.

Insert the control hoses:

See illustration on page 24, top.

Compressed air
with hose designation 1 or colour: white

Direction of movement "lift"
with hose designation 2 or colour: green

Direction of movement "lower"
with hose designation 3 or colour: red



ATTENTION!

The control hoses must not be subject to tensile load; adjust the protective sleeve accordingly.

Pull the bellows over the hose adapter and secure via the central bolt (see illustration on page 24, bottom).

REPLACING CONTROLS

Conversion to another type of control is a significant modification to a hoist. Following conversion, national safety regulations, including testing regulations, must be observed. If you wish to exchange air controls E, F or FI, proceed as follows (see illustrations in Connecting the controls section)

CONVERSION FROM E TO F

Control valve housing (on motor)

Removal of E-controls

Remove the hose adapter (secured by central bolt). For removal of the hose adapter, a long A/F 6 socket spanner must be guided through the middle of the bellows and inserted into the hexagon socket of the bolt (illustration on page 24, bottom).

Pull the bellows back over the hose until the hose nipples with the one-ear clamps are exposed and further removal is possible.

Detach the strain-relief rope and remove the one-ear clamps (see **Removal** illustration, page 23).

Cut off the hoses below the hose nipples using a knife. Unscrew the hose nipples (A/F 17).

Pull the bellows over the hoses of the E-controls. This is also required for the F-controls.

Installation of F-controls

Pull the bellows over the hose bundle for F-control. Remove approx. 80 mm of the hose bundle protective sheathing or 160 mm for additional movements. Screw the "straight screw connections" (Steck-fix) for 4 mm hoses into the hose adapter (A/F 16).

Pull the strain-relief cables through the eye bolt and secure using cable clamps.

Insert the control hoses:

See illustration on page 24, top.

Compressed air
with hose designation 1 or colour: white

Direction of movement "lift"
with hose designation 2 or colour: green



Direction of movement "lower"
with hose designation 3 or colour: red



ATTENTION!

The control hoses must not be subject to tensile load; adjust the strain-relief cables accordingly.

Pull the bellows over the hose adapter and secure via the central bolt, (see page 24, bottom).

CONVERSION FROM E TO FI

Removal of E-controls as previously described (page 25).

Installation of FI-controls

Pull the bellows over the hose bundle for FI-control. Remove approx. 80 mm of hose bundle protective sheathing.

Screw the "straight screw connections" (Steck-fix) for 4 mm hoses into the hose adapter (A/F 16).

With this type of control, strain-relief of the hand controls takes place via the protective sleeve of the hose bundle. For this purpose, the protective sleeve is pushed onto the hose carrier and is secured using a one-ear clamp.

Installation facilitation: Heat the protective sleeve (hose sheathing) with a hot-air gun and grease the hose carrier.

Slightly bend open the ring of the eye bolt in order to attach the hose carrier.

Close the ring again to prevent detaching.

Insert the control hoses:

See illustration on page 24, top.

Compressed air
with hose designation 1 or colour: white

Direction of movement "lift"
with hose designation 2 or colour: green

Direction of movement "lower"
with hose designation 3 or colour: red



ATTENTION!

The control hoses must not be subject to tensile load; adjust the protective sleeve accordingly.

Pull the bellows over the hose adapter and secure via the central bolt (see illustration on page 24, bottom).

Conversion from rope control to air control:

Remove the rope control lever by removing the M6 x 12 bolt from the control shaft.

The connecting surface of the hose adapter on the valve housing is closed off by means of a disc with an M8 x 16 countersunk screw. Following removal of the countersunk screw and of the disc and dowel pin (5 x 12 dowel pin), the hose adapter of air control can be installed as described in the previous section.

CONVERSION FROM AIR CONTROL TO ROPE CONTROL

Air controls can only be installed on rope controls that feature a control shaft.

Removal of air controls

Remove the hose adapter (secured by central bolt). For removal of the hose adapter, a long A/F 6 socket spanner must be guided through the middle of the bellows (illustration on page 27).

Installation of rope controls

The connecting surface of the hose adapter on the valve housing is closed off by means of a disc and is secured with the M8 x 16 countersunk screw. The dowel pin (roll pin) must be inserted in the bore provided.

Push the rope control lever onto the control lever and secure with the M6 x 12 bolt and washer. It must be ensured that the both ends of the control lever point downwards (in the direction of the load hook and not in the direction of the motor). Guide the control ropes from the side facing the valve through the bores in the control lever and knot them. Rope colour: "green" lift, "red" lower. Further, see section **Connecting the rope control**.

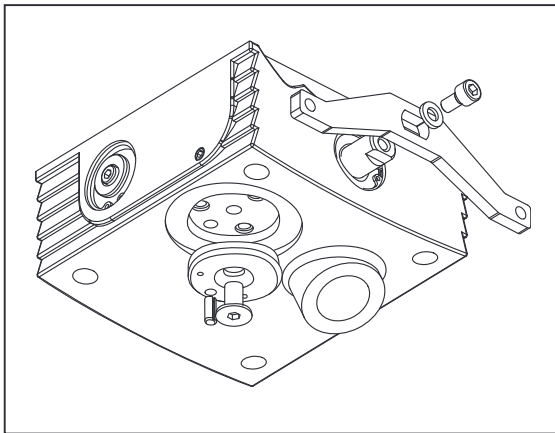

Installation of rope controls

CONNECTING TO THE MAIN AIR SUPPLY

- ▶ Check air connection for contamination and clean if necessary.
- ▶ Blow through compressed air hose in order to remove foreign bodies.
- ▶ Attach the compressed air hose to the connection on the hoist or on the service unit. Tighten the union nut.

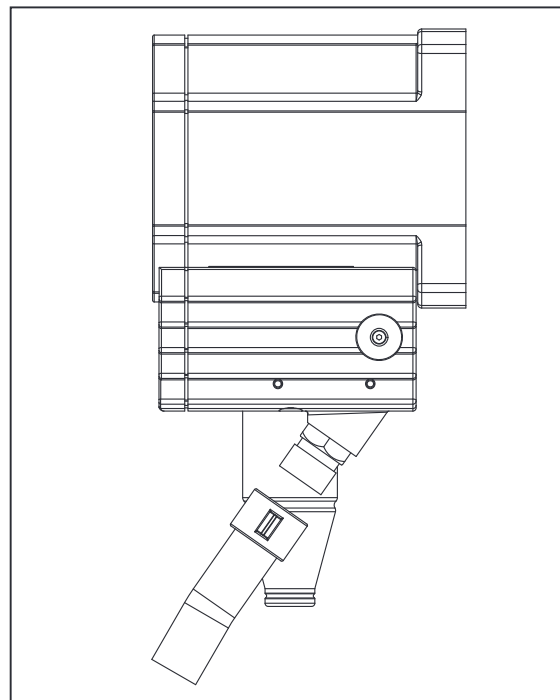

Attach the compressed air hose and tighten the union nut.



LUBRICANTS

The following lubricants are intended for normal environmental influences. If the trolley is operated under adverse conditions that induce increased wear, consult J.D. NEUHAUS, for further information.



CAUTION!

Oil and grease can cause skin irritation. Wear protective gloves at all times.



ATTENTION!

Potential damage! Do not mix synthetic oils or greases with mineral oils, as the properties may be impaired.

Also, never mix different types of lubricating grease within the synthetic or mineral lubricant groups.

Synthetic lubricants must not be used when operating with oilers. Alcohols are not permitted for use as anti-icing agents.

Application	Lubricant
Motorlubrication - at factory - for operation with oiler	- JDN high-performance grease Part No. 11901 (250 ml) - Air motor oil type "D", kinematic viscosity approx. 30 mm ² /s (cSt) at 40° C, anti-icing additive if required
Chain lubrication	Chain oil or motor vehicle engine oil, kinematic viscosity approx. 150 mm ² /s (cSt) at 40° C, or special lubricant from J.D. NEUHAUS In areas with very high corrosion potential, e.g. off-shore, a lubricant with especially high-performance anti-corrosion properties must be used.
Motor conservation (not applicable when using JDN high-performance grease)	Non-resinous protective oil rated for the duration of the storage period
Motor cleaning (not applicable when using JDN high-performance grease)	Pure petroleum
Lubrication of bearings and gearboxes (also for exposed gears)	Saponified lithium grease, felting penetration 265-295 (0.1 mm), ground oil viscosity: 190 cSt (mm ² /s) at 40° C, dripping point: 180° C, operating temperatures: - 20° C to + 120° C, designation in accordance with DIN 51825: KP2K-20, active agents: EP additives (for wear-reduction) and ageing protection; water resistant and corrosion protection



INSPECTION BEFORE INITIAL OPERATION

Hoists, including the supporting structure, must be inspected by an appropriately trained and qualified person before initial operation and before re-commissioning after significant modifications. Hoists and lifting gear which are installed in trolleys must be inspected by a specialist.

The inspection covers the proper mounting, equipment level and operational-readiness etc., in the main, the completeness, suitability and effectiveness of the safety devices as well as the condition of the device, the harness, the equipment and the supporting structure.

Safety devices are braking devices, overload protection devices, EMERGENCY STOP devices, lifting and lowering limiters (emergency end-stop devices).

A description of the inspections can be found in the **Maintenance** section, page 39.



OPERATION

RULES FOR SAFE OPERATION OF HOISTS

As a hoist operator, you are responsible for your own safety and that of your colleagues in the working area of the hoist.

- ▶ Hoists may only be operated by persons charged with this task by their company.
- ▶ Before using the JDN Air Hoist for the first time, familiarise yourself with all permissible operating conditions. For this purpose, read through this operation manual thoroughly and carry out the described actions on the hoist, step by step.
- ▶ Report each malfunction to your safety officer immediately, so that the fault can be remedied without delay.
- ▶ Adhere to the regulations of the accident prevention authorities (e.g. trade association regulations in Germany).
- ▶ Read the section **Intended use**, page 15.

The following situations, among others, are regarded as improper use:

- ▶ Changing load-carrying capacity depending on load position: JDN Air Hoists are not equipped with load-carrying capacity indicators, they may therefore only be used in those applications in which the load-carrying capacity does not change with the position of the load.
- ▶ Oblique pulling of loads in general.

Definition of oblique pulling

Oblique pulling is the deviation of the load chain and the chain hoist from the vertical position, for a force acting in a straight line between the force's point of application of the load on the load hook and the suspension on the supporting structure.



Oblique pulling

Under special safety provisions relevant to the particular situation, JDN Air Hoists may be used for oblique pulling (see **Intended use**, page 15). In this case, a chain box must not be used, as the chain may fall out or become knotted. Oblique pulling is not permitted for hoists installed in trolleys or in running gears. Please contact us, if required.

- ▶ Breaking loads free or dragging loads.
- ▶ Loading of the hook at the tip.
- ▶ Catching falling loads.
- ▶ Carrying persons (see **Intended use**, page 15).
- ▶ Jog control with load on the hook.
- ▶ Switching to the opposite direction with the load in motion.
- ▶ Reaching lifting and lowering limiters as part of normal operation.
- ▶ Never hold the centre section of the chain under tension when the load hook is in the upper or lower limit position.

JDN Air Hoists must not be used for the following applications, for example:

- ▶ Critical areas of nuclear plants.
- ▶ Over acid baths or other plants with corrosive substances.
- ▶ In areas in which organic acids are present.

To ensure the safety of personnel and property when using JDN Air Hoists, it is essential that the following points are observed:

- ▶ Lift the load carefully at first.
- ▶ Never touch a running chain.
- ▶ Never use the hoist chain for attaching loads.
- ▶ Never allow loads to fall into the hoist chain.
- ▶ If the chain is slack, do not take up the load at maximum speed.
- ▶ Only use **original JDN chain boxes**.
- ▶ Do not exceed the permitted filling capacity of the chain box.
- ▶ When operating without a chain box, avoid hazards due to idle chain (falling, catching, impacting), see section **Operation without chain box**, page 19.
- ▶ Never apply bending loads to chains.
- ▶ Do not join or repair chains.
- ▶ Do not operate with a chain which is drawn tight, bent or extended.
- ▶ Check jammed chains for damage.
- ▶ Straighten twisted chains (defective bottom block)
- ▶ Do not operate with damaged, worn or rusty chains.
- ▶ Permitted operating temperature for chain and hook:
 - 20° C to + 150° C, permissible ambient temperature:
 - 20° C to + 70° C, permitted heat absorption of hoist body: max. 90° C.
- ▶ Never allow persons to enter the area below the suspended load.
- ▶ Never attempt to remedy a fault with a load suspended from the hoist.
- ▶ Only use suitable and approved sling gear; do not jam the hook at the point of attachment.
- ▶ Ensure that the operator is not put at risk within the operating area by attaching aids or the load.
- ▶ Follow the relevant instructions for attaching loads.
- ▶ Before attaching, accurately position the load vertically below the hoist. The chain must hang vertically before lifting.
- ▶ Ensure that the hook safety catch is closed.
- ▶ Repair damaged hook safety catches.
- ▶ Before lifting loads, ensure that the maximum permitted load is not exceeded. Sling gear must be included in the weight of the load.
- ▶ When taking up and setting down, ensure stable positioning of the load, to prevent accidents due to tilting or falling loads.
- ▶ Never force jammed loads.
- ▶ Only lift one load at a time, never several loads simultaneously.
- ▶ Never lock the control elements of control devices.
- ▶ If the control elements become difficult to operate, have the hoist repaired.
- ▶ In the case of power failure, secure the load and the surrounding area until the power is restored.
- ▶ Never use or repair bent, open or deformed load hooks. The hoist must be expertly repaired and the hook replaced.
- ▶ Never anneal the hook.
- ▶ Only operate JDN Air Hoists with **original JDN controls**.
 - ▶ Uncontrolled, external force factors (e.g. due to hydraulic cylinders, falling loads) are not permitted.
 - ▶ Repair stiff hook bearings.
 - ▶ Do not kink or pinch control hoses.
 - ▶ Have loosened bolted connections tightened by the Repairs department.
 - ▶ Before removing compressed air hoses, shut off the main air supply.
 - ▶ If the braking distance is excessive, repair the hoist.
 - ▶ If a load is lifted using several air hoists, prevent overloading due to incorrect weight distribution.
 - ▶ Select a safe operating location.
 - ▶ Ensure the correct system pressure.
 - ▶ Never touch metallic hand controls which are colder than 0° C or hotter than 43° C, without suitable protective gloves.
 - ▶ Do not make modifications to the hoist.
 - ▶ Only use **original JDN spare parts**. J.D. NEUHAUS GMBH & CO. KG accepts no liability for the use of non-original components and/or modifications.
 - ▶ If, in the case of multi-chain hoists, the bottom block is lying on the floor, move it back to a hanging position in a controlled manner (evenly-loaded chains).
 - ▶ Special safety precautions must be taken when loads are being hoisted into areas that are out of sight.





DANGER!

For all air hoist applications, ensure that the load hook can be lowered all the way to the ground, in order to prevent a load being moved to the lower limit position, without reaching the ground. Danger due to overloading



DANGER!

Never use hoists lying on the ground if they are not specifically intended for horizontal pulling.



DANGER!

The fatigue strength of chains is significantly impaired due to extreme corrosion (pitting corrosion). **Risk of fracture.** Hydrogen-induced embrittlement with resultant stress cracks due to highly corrosive media (e.g. sea water) may affect high-strength steels (e.g. chains). Risk of fracture! This process is promoted by so-called recombination poisons. Examples of these are hydrogen sulphide, cyanide, arsenic compounds and rhodanide. If rusty chains are not replaced for operational reasons, crack inspections are to be carried out at intervals of three months.

Furthermore, it is essential that all the regulations set out in sections **Intended use**, page 15 and **Operating conditions**, page 16 are observed.

Company operating instructions

Where hoists are to be employed under particularly difficult conditions, the company must provide operating instructions in easily comprehensible form, in the language of the operator, based on the instructions in this manual. Here, measures for safe operation are stipulated in accordance with prevailing operating conditions.



CONTROLS

JDN Air Hoists can be equipped with a variety of control devices. They are all suitable for use in explosion-hazardous areas.

All control switches return to the zero position when released.

CONTROL VALVE ON MOTOR

Air control (E, F, FI controls) with upstream main-stream valve

The control valve consists of:

1. Main-stream valve
2. Direction control valve as slider with sleeve

The main-stream valve lies upstream from the direction control valve. If no control pressure is present, the valve is closed and the direction control valve is depressurised. If control pressure is applied from the hand control, the valve opens and releases the main stream.

If the red EMERGENCY STOP button on the hand control is pressed, all control lines are depressurised and the main-stream valve is closed.

Air control (E, F, FI controls) without upstream main-stream valve

The control valve consists of:

Direction control valve as slider with sleeve

Rope control valve without upstream main-stream

The control valve consists of:

1. Direction control valve as slider with sleeve
2. Positioner

The direction control valve positioner (sleeve with slider) is connected directly to the control lever via the control shaft.

E CONTROL

With E-control, lifting and lowering movements can be controlled via two pushbuttons. The direction of movement of the load hook is marked on the upper side of the valve housing, above the pushbuttons.

- ▶ Lift: Press the right pushbutton.
- ▶ Lower: Press the left pushbutton.

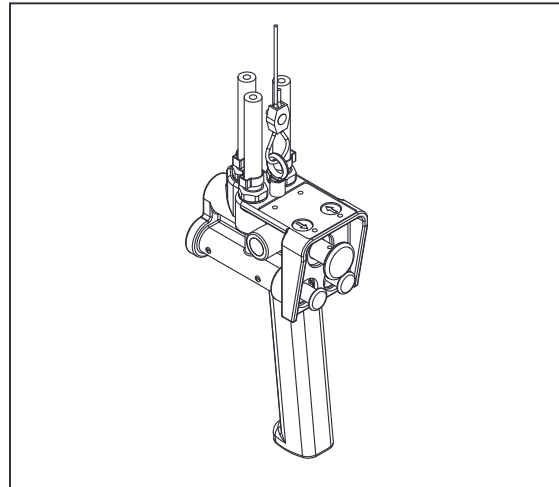

E-control with EMERGENCY STOP button



PUSHBUTTON F-CONTROL

With pushbutton F-control, lifting and lowering movements can be controlled via two pushbuttons. The direction of movement of the load hook is marked by arrows next to the pushbuttons.

- ▶ Lift: Press the upper pushbutton.
- ▶ Lower: Press the lower pushbutton.

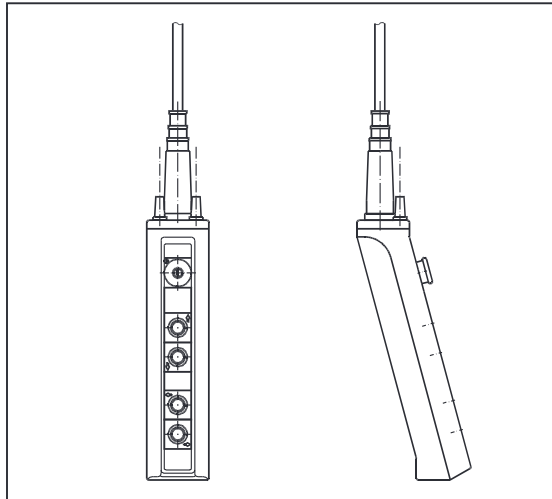

F-control with EMERGENCY STOP button

PUSHBUTTON FI-CONTROL

With pushbutton FI-control, lifting and lowering movements can be controlled via two pushbuttons arranged side by side. The control pressure is infinitely variable, enabling precise positioning of the load. The direction of movement of the load hook is marked by arrows on the pushbuttons.

- ▶ Lift: Carefully press the right pushbutton. The load is lifted slowly.
- ▶ Press the pushbutton further down, in order to increase the lifting speed.
- ▶ Release the pushbutton slightly in order to reduce the lifting speed.
- ▶ Lower: Carefully press the left pushbutton. The load is lowered slowly.
- ▶ Press the pushbutton further down in order to increase the lowering speed.
- ▶ Release the pushbutton slightly in order to reduce the lowering speed.

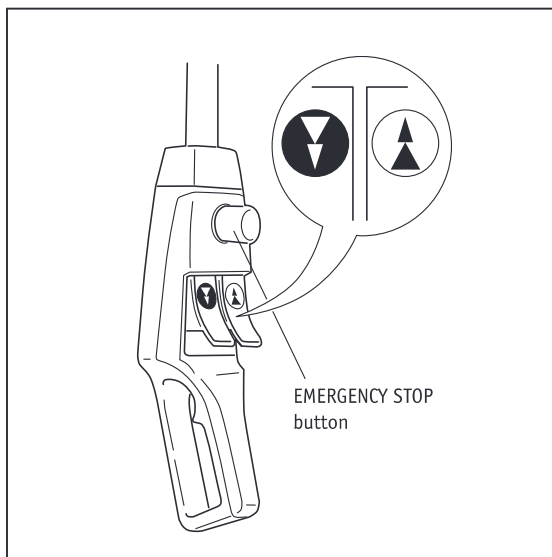

FI-control with EMERGENCY STOP button

EMERGENCY STOP DEVICE

Within the EU, these controls are equipped with an EMERGENCY STOP device (optional outside the EU).

In order to avert danger produced by the lifting movement as quickly as possible, release the pushbuttons - the movement of the load is then interrupted immediately.

Only press the red EMERGENCY STOP button firmly if this Stop function fails. The EMERGENCY STOP button engages. This results in the closing of a separate check valve and the load hook comes to rest instantaneously. The pushbuttons for lifting and lowering now no longer function.

The EMERGENCY STOP button can be released again by turning clockwise. It jumps back into place.



DANGER!

Never release the EMERGENCY STOP button before the danger has been eliminated and the stop function via the pushbuttons has been restored.

ROPE CONTROL

With rope control, the lifting and lowering movements are controlled directly. Both rope ends are connected to one another via a handle, enabling precise one-hand operation. The direction of movement is marked by arrows on the handle.

The control elements for rope control and the energy-switching component of the control valve on the motor (reversing valve) are positively connected to one another. This connection is designed in such a way that, in an emergency, the control valve can be reset to a stable neutral position. Thus, no additional EMERGENCY STOP device is required.

- ▶ Lift: Carefully pull on the green rope with the green handle pin. The load is lifted slowly.
- ▶ Pull harder on the rope, in order to increase the lifting speed.
- ▶ Release the rope slightly in order to reduce the lowering speed.

- ▶ Lowering: Carefully pull on the red rope with the yellow handle pin. The load is lowered slowly.
- ▶ Pull harder on the rope, in order to increase the lowering speed.
- ▶ Release the rope slightly, in order to reduce the lowering speed.

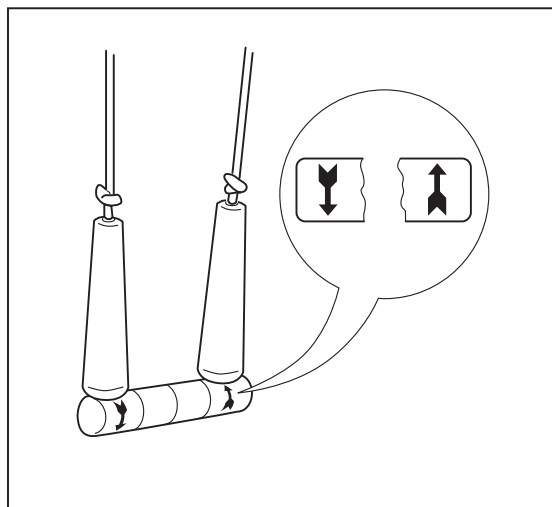

Rope control



OVERLOAD PROTECTION

The overload protection limits the operating pressure of the compressed air supplied. It responds as a function of load and is set to a limit value of approx. 125 % of the nominal load. The force limiting factor then has a value of 1.25.

When the overload protection is activated, the lifting movement is possible again once the lowering movement has been switched (unloading the hoist).

The overload protection may also respond when moving at full unloaded speed against a load to be lifted, even when it is below the load size set. We therefore recommend tensioning the slack chain before lifting the load.

ATTACHING THE LOAD



DANGER!

Only use attaching cables or attaching chains which are suitable for the load. Attaching must not be attempted by winding with the lifting chain around the load.

In Germany, the trade association regulations "Operation of load carrying devices used with lifting equipment" (BGR 258) must be adhered to. In other countries, the relevant local regulations must be observed.

- ▶ Attaching aids must be attached at the lowest point of the hook. Never load the tip of the hook.
- ▶ Ensure that the hook safety catch is closed.

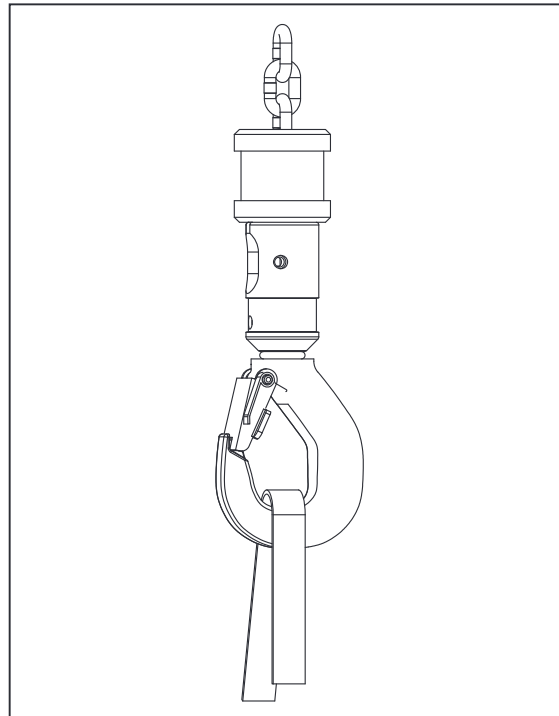

Attach the load safely

LIFTING THE LOAD**ATTENTION!**

JDN Air Hoists must be capable of alignment under load. Otherwise impermissible additional forces can occur, which can damage the hoist components.

- ▶ First, lift the load hook, in order to pull the slack chain tight. With the chain tight, briefly interrupt the lifting procedure. The hoist can align itself and the material is protected.
- ▶ Then lift the load.

The overload protection system aborts the lifting operation in the event of loads whose weight is more than the pre-defined limit value for the overload protection (see **Overload protection** section, page 59).

LOWERING THE LOAD**DANGER!**

Ensure that there are no persons below the load.

- ▶ Then lower the load and ground it carefully.

**DANGER!**

For all air hoist applications, ensure that the load hook can be lowered all the way to the ground, in order to prevent a load being moved to the lower limit position without reaching the ground. Danger due to overloading!

DETACHING THE LOAD

- ▶ Lower the load hook far enough, so that the load can be easily detached.
- ▶ Move the load hook out of the lifting area, in order to avoid hazardous situations.

INTERRUPTING WORKING

If you wish to interrupt working with your JDN Air Hoist:

- ▶ Set down and detach the load.
- ▶ Move the load hook out of the lifting area, in order to avoid hazardous situations.



TAKING OUT OF OPERATION

SHUTTING DOWN

If the hoist is to be taken out of operation for a longer period of time it must be protected against corrosion and dirt.

- ▶ Coat the chain and hook with a light oil film.
- ▶ Move the load hook out of the lifting area, in order to avoid hazardous situations.
- ▶ Do not move against the lifting and lowering limiters/buffers (emergency end stop devices).
- ▶ Depressurise the air line.

STORAGE

(see section **Storage conditions**, page 20)

DISMANTLING



DANGER OF INJURY!

JDN Air Hoists must only be dismantled by qualified personnel.

- ▶ Depressurise the air line.
- ▶ Provide a suitable working platform.
- ▶ Loosen the union nut and remove the air hose.
- ▶ Protect the air connection against the dirt ingress.
- ▶ Detach the control hoses from the hoist. Do not kink the control hoses.
- ▶ Mark the connections.
- ▶ Detach the strain-relief and hose carrier and remove the control device.
- ▶ Carefully detach/dismount the hoist and remove.
- ▶ For trolleys, proceed in reverse order to that described in the section on mounting trolleys (in the trolley operation manual).

DISPOSAL

JDN Hoists contain a range of materials which, on expiry of the service life, must be disposed of or recycled where appropriate, in accordance with statutory regulations.

Please note the following list of materials used:

HOIST

- ▶ Ferrous materials
 - Steel
 - Nodular cast iron
- ▶ Non-ferrous metals
 - Bronze
 - Aluminium
- ▶ Plastics
 - Polyethylene
 - Polyurethane
 - Polyoxymethylene
 - Polyvinyl chloride
 - Polyamide, glass-fibre reinforced
 - Natural rubber
 - Epoxy resin
 - Polyacetal
 - Polypropylene
 - Phenol resin
 - Thermoset moulding compound (asbestos-free brake lining)
 - Polyester
 - Synthetic rubber
 - Wool felt

FILTER SILENCER/ SERVICE UNIT:

- Zinc diecast
- Brass
- Nitrile rubber
- Aluminium
- Polypropylene
- Polyurethane
- Glass-fibre reinforced plastic
- Steel
- Polyacetal
- Polyethylene



MAINTENANCE

MAINTENANCE AND INSPECTION INTERVALS

JDN Air Hoists are extremely robust and require little maintenance. Compliance with maintenance and inspection intervals is of great importance in order that the hoist operates safely and reliably over a period of many years.



CAUTION!

Maintenance work on JDN Air Hoists must only be performed by trained and qualified personnel.

CLEANING AND CARE

If your JDN Air Hoist is often used at different locations, particularly in dirty and damp environments,

- ▶ clean any dirt off the hoist and the chain,
- ▶ seal off the air supply connections,
- ▶ protect the hoist and, in particular, the chain from corrosion,
- ▶ store the hoist in a clean and dry place.

SPARE PARTS

If, during repair work, the replacement of components is necessary, only **original JDN spare parts** may be installed.

LUBRICANTS

(see section **Lubricants**, page 28)

INSPECTION AND REPAIRS

Series lifting equipment is classified into groups and dimensioned according to the type of operation (Driving mechanism classification according to ISO/FEM). The average daily operating time and the load spectrum determine the classification. This is assuming that the lifting and lowering paths are approximately the same.

For devices used mainly in vertical operation (from 75 % of on-time), the theoretical operating time is reduced due to the higher lowering speed in the range from 50 % to 100 % of the nominal load.

Therefore, the determined portion of the theoretical operating time must be multiplied by a factor of f_v .

The factor f_v has a value of 1 to 50 % of the nominal load, increasing linearly to 1.5 at 100 % of the nominal load (nominal load percentage P).

$$f_v = 1 + 0.5 \frac{P-50}{50} \quad (\text{for } P > 50\%)$$

In order to achieve safe operating periods, the company must check that the theoretical operating time has been achieved during each inspection, by the person responsible. This must be documented in the inspection log at least once annually. The inspection log is only supplied in the Federal Republic of Germany. Instructions and a model for determining the actual operating time can be found from page 41 onwards.

When the theoretical operating time has been reached, a general overhaul must be performed. Detailed explanations for the determination of the actual operating time and its documentation can be found in the national safety regulations. Alternatively, the calculation model in this operation manual can be used. The general overhaul must be initiated by the operator and must be documented in the inspection log. Information on general overhaul can be requested from the manufacturer.



Only if the group classification corresponds to the actual type of operation of the lifting equipment, does a safe operating period conform to the theoretical operating time. Deviations of the actual type of operation from that used for calculation extend or shorten the safe operating period.

For all inspection work which is not a part of the daily inspection, suitable access must be made to the hoist. The hoist must be disconnected from the main air supply during assembly work.

Dismantling the hoist, see page 38.



CAUTION!

Following each repair, the hoist must be checked for operational readiness.



INSTRUCTIONS CONCERNING THE “MODEL FOR DETERMINING THE ACTUAL OPERATING TIME”

The decisive factors for the type of operation are the load spectrums with different cubic averages k . The load spectrum indicates to what degree a driving mechanism, or a part of one, is subjected to its maximum stress or only to smaller stresses. The cubic average (factor of the load spectrum) is calculated using the following formula.

$$k = \sqrt[3]{(\beta_1 + \gamma)^3 \cdot t_1 + (\beta_2 + \gamma)^3 \cdot t_2 + \dots + \gamma^3 \cdot t_\Delta}$$

Definitions:

$$\beta = \frac{\text{Maximum or ultimate load}}{\text{Load-bearing capacity}}$$

$$\gamma = \frac{\text{Dead load}}{\text{Load-bearing capacity}}$$

$$k = \frac{\text{Operating time with maximum load or partial load and dead load}}{\text{Total operating time}}$$

$$t_\Delta = \frac{\text{Operating time with dead load}}{\text{Total operating time}}$$

The FEM* 9.511 rule differentiates between four load spectrums, which are identified by the definitions and by the ranges of the cubic averages k . This classification complies with ISO 4301/1.

*FEM = Federation Europeene de la Manutention (European Federation of Materials Handling and Storage Equipment)

The formula given for the cubic average k does not take the weight of the harness into account. This is permissible if the ratio

$$\frac{\text{Weight of harness}}{\text{Load-bearing capacity}} \leq 0.05$$

To determine the type of operation for calculating the partial operating times (actual operating time), the following load spectrum diagrams can also be used.

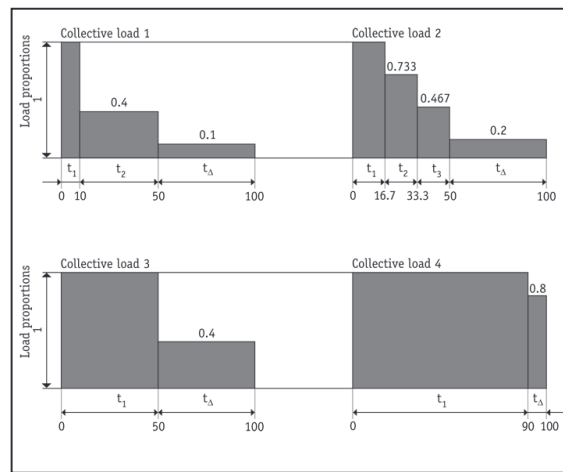

Load spectrum	Definition	Cubic average	Load spectrum factor
1 (Low)	L1 Driving mechanisms or parts thereof, which are only subject to the maximum stress in exceptional circumstances, and are only subject to very low stresses continuously.	$k \leq 0.50$	$k_m = k^3 = 0.125$
2 (Average)	L2 Driving mechanisms or parts thereof, which are subject to the maximum stress fairly often, and are only subject to low stresses continuously.	$0.50 < k \leq 0.63$	$k_m = k^3 = 0.25$
3 (High)	L3 Driving mechanisms or parts thereof, which are often subject to the maximum stress, and are continuously subject to average stresses.	$0.63 < k \leq 0.80$	$k_m = k^3 = 0.5$
4 (Very high)	L4 Driving mechanisms or parts thereof, which are regularly subject to the maximum stress of adjacent stresses.	$0.80 < k \leq 1.00$	$k_m = k^3 = 1$



The specified inspection intervals are valid for use in accordance with the classification (see driving mechanism classification on the nameplate). The service life is approx. 10 years if the device is used in accordance with its classification. If the hoist is used more intensively the intervals are to be shortened accordingly. The intensity of use must be assessed using the **model for determining the actual operating time** (see page 41). All operating hours are translated into full load hours. The theoretical operating time and the interval hours are indicated in full load hours.

Maintenance measure	Interval	Comment
Check oil level for motor lubrication (when operating with oiler)	Daily	(Filling and adjusting oiler section, page 49)
Lubricate chain	As required	(Lubricating the chain section, page 45)
Visually check the chain	Weekly	

Inspection measure	Interval	Comment
Check control device	Daily	(Checking controls section, page 46)
Check the braking function	Daily	(Checking braking function section, page 45)
Checking direction of movement	Daily	(Checking direction of movement section, page 46)
Check lifting and lowering limiters (buffers) visually	Daily	Replace buffer immediately if damaged, otherwise replace every 5 years
Check EMERGENCY STOP function	Daily	
Check chain	Every 3 months	(Checking chain, chain sprocket and chain guides section, page 55) In the event of wear-promoting operating conditions, reduce intervals between checks
Checking lifting and lowering limiters	Annually	(Checking lifting and lowering limiters , section, page 46)
Check brakes with load	Annually	Load must be braked reliably (Checking braking function section, page 45)
Check all the bolted and-pin connections	Annually	
Check load hook on the load and carrying side	Annually	(Check dimensions section, page 55)
Check the motor, check, clean and grease the control valve (JDN high-performance grease)	Annually	Measure the lifting speed
Check the axial movement of the hooks and eyes	Annually	(Checking axial play section, page 57)
Check the service unit ¹	Annually	(Service unit section, page 47)
Check the silencer for permeability	Annually	(Checking silencer for permeability section, page 46)
Check overload protection	Annually	(Checking and adjusting overload protection section, page 59)
Check compressed air connections for damage	Annually	

¹if fitted

Inspection measure	Interval	Comment
Check sealing efficiency and function of control valve	Annually	
Check condition of the chain box ¹	Annually including mountings	(Chain box section, page 63)
Check for brake wear and motor vane wear	Every 200 hours, at least every 5 years	(Checking brake linings and vanes section, page 50), replace motor vanes every 5 years.
In off-shore areas and other similar corrosive environments, replace the chain regularly	Every 5 years	
Check gearbox and perform lubricant change	Every 5 years	
Check the rotor/pinion shaft connection and lubricate with gear grease	Every 5 years	
Check the chain sprocket bearings and lubricate if necessary	Every 5 years	
Check chain sprocket and chain guides	Whenever the chain is replaced	(Wear dimensions section, page 56)
Renew grease lubrication of motor	When required, at least every 5 years	(Motor lubrication section, page 50)

¹ if fitted

LUBRICATE CHAIN

The chain of the JDN Air Hoist must be lubricated in the links when not under load.

- ▶ Clean heavily contaminated chains.
- ▶ Lay the chain in a suitable container.
- ▶ Spray the chain with special lubricant or motor vehicle engine oil.

If you wish to lubricate the hanging chain, ensure that the chain links are oiled at the points of contact. For this purpose, move the chain to and fro.

A high-performance lubricant in an aerosol can is available from JDN, which adheres well to the chain after the solvent has evaporated and does not drip off, Part No. 12066 (spray can 400 ml).

For operation in areas with high corrosion potential, e.g. in the offshore sector, the chain can be largely protected against corrosion by the use of special lubricants.

These types of lubricants are characterised among other things by weathering resistance, water insolubility and good adhesion properties.

Re-lubrication intervals must be stipulated in accordance with the loading. Please contact us, if required.

CHECK THE BRAKING FUNCTION

Check the function of the brake daily as follows:

- ▶ Switch the unloaded air hoist alternately between lifting and lowering modes.

If a control element is released, the chain must be seen not to run on.



DANGER!

If the chain runs on, do not use the hoist. The hoist must be repaired.

For physical reasons, the braking distance cannot have the value zero. However, for the purpose of this functional check, running on of the chain must not be perceptible.

When checking the braking function under nominal load, the following braking distances must not be exceeded:

BRAKING DISTANCES UNDER NOMINAL LOAD (LOAD-CARRYING CAPACITY) AFTER LOWERING HAS BEEN STOPPED

Type	1.5 TI	3 TI/2
Rope control	10	5
all other controls with length of 2 m	33	16

Dimensions in mm

If the control hoses are long the braking distances will increase due to longer air evacuation times.



CHECKING LIFTING AND LOWERING LIMITERS

- ▶ Move the unloaded load hook until just short of the upper and lower end positions.
- ▶ Stop immediately before reaching the end position and then carefully (by repeatedly pressing the control element) move to the end position.
- ▶ The movement of the chain must be stopped due to deformation of the buffer. For hoists with overload protection, the lifting movement is additionally limited by shutting off the motor.
- ▶ Following successful testing, the buffer must be unloaded.



DANGER!

If the buffer is damaged, do not use the hoist. The hoist must be repaired (replace the buffer).

CHECKING CONTROLS AND EMERGENCY STOP FUNCTION

All control elements of the controls must always be free-moving.

- ▶ Unload the JDN Air Hoist.
- ▶ Briefly actuate and release all control elements of the controls one after the other. The control elements must return to their initial positions immediately. The on and off function must operate without problem.
- ▶ PRESS THE EMERGENCYSTOP. All movement of the hoist must stop. Actuating the control elements must not cause a lifting or lowering movement.
- ▶ RELEASE THE EMERGENCY STOP button by turning.



DANGER!

If a control element is stiff or remains in the actuated position, do not use the hoist. The control must be repaired.

CHECKING THE MAIN AIR EMERGENCY STOP VALVE

The main air emergency-stop valve is opened with each actuation of the controls. It closes when the controls are released.

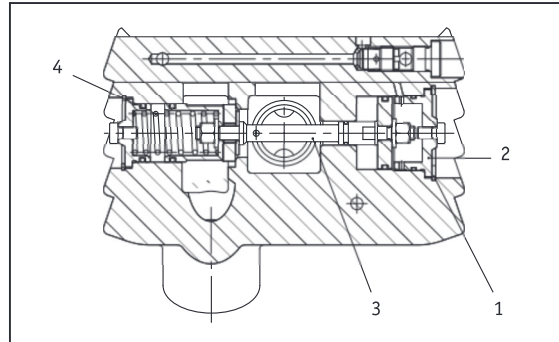

Main air emergency-stop valve

With each check, the working order of the valve must be examined as follows:

- ▶ Shut off the compressed air supply and unload the line.
- ▶ Remove the safety ring 1.
- ▶ Pull out the cover 2.
- ▶ Press plunger 3 inwards against the force of spring 4. It must return again due to the spring force.
- ▶ If the plunger does not move, the valve must be repaired.

CHECKING DIRECTION OF MOVEMENT

- ▶ Check that the direction of movement of the load hook corresponds to the direction indicated by the arrows on the control elements.

CHECK THE SILENCER FOR PERMEABILITY

Independent of the stipulated inspection intervals, the silencer must be checked for permeability if the hoist does not achieve the specified lifting speed (see section **Technical data**, page 64).

The test is performed by comparing the lifting speeds under nominal load, with and without the silencer. The speed with standard silencer or filter silencer must be at least 80 % of the lifting speed without a silencer element. In the event of lower values, the silencer elements must be cleaned or replaced.



SERVICE UNIT



ATTENTION!

If a hoist is operated with a service unit, this should not be mounted further than 5 m away from the hoist.

The ambient temperature must be a minimum of 0° C. It must not exceed 50° C.

NOTE: If, at the request of the customer, a service unit is installed in hoists in motorised trolleys and lifting gear, it will be configured at the factory.

A maximum connecting pressure of 10 bar is permitted for the service units supplied by JDN. Higher pressures must be reduced to a permitted amount upstream of the service unit.

The service unit in the PROFI 1.5 TI and PROFI 3 TI/2 Air Hoists consists either of two elements, filter controller and oiler, or of the filter controller only.

CHECKING AND ADJUSTING THE FILTER CONTROLLER*)

The filter controller is set to an actual pressure in the factory (actual pressure when lifting the nominal load). In this setting, the manometer can indicate a pressure above the nominal pressure with the motor switched off. For correct adjustment, a pressure of at least 1 bar above the nominal pressure is required upstream of the service unit.

- ▶ Lift the regulator knob.
- ▶ Turn the regulator knob until the manometer indicates the nominal pressure. Clockwise: higher pressure Anti-clockwise: lower pressure
- ▶ Lock the regulator knob by pressing it down.

Alternatively, the filter regulator can be set to the nominal pressure in the absence of an air stream. This setting is only correct for a pressure of at least 1 bar above the nominal pressure upstream of the service unit.

- ▶ Depressurise the air line downstream of the service unit and close it again.
- ▶ Turn the regulator knob anti-clockwise, in order to release the adjusting spring.

- ▶ Turn the regulator knob until the manometer indicates the nominal pressure. Clockwise: higher pressure Anti-clockwise: lower pressure
- ▶ Lock the regulator knob by pressing it down.

If the nominal pressure cannot be achieved despite a sufficiently high pressure upstream of the service unit, then the air line cross-section is too small.



Filter regulator and oiler

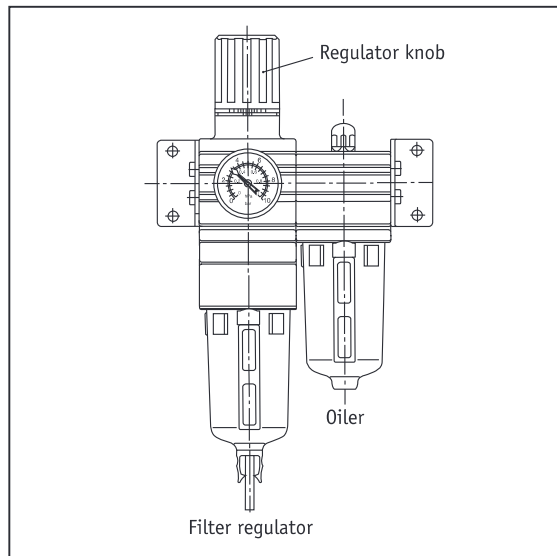

DRAINING CONDENSATE

After a certain time, condensate collects in the filter regulator container, which must be regularly drained. Check the condensate level through the sight glass in the filter container. The condensate level must not reach the separating plate.

The container can be emptied manually or semi-automatically, depending on the setting of the drain valve:

- ▶ **OFF position**
The drain valve is closed in this position. The OFF position is generally set at the factory.
- ▶ **ON position**
The condensate can be drained manually in this position. Operate the drain valve by pressing upwards (see Figure).
When the compressed air supply is connected, the drain valve is under pressure. We recommend using suitable splash protection (cloth, fleece) as the condensate will otherwise escape uncontrollably. Collect the escaping condensate and dispose of it as it may contain oil.
- ▶ **AUTO position**
In this position, semi-automatic condensate drainage takes place. When the pressure upstream of the service unit falls below 0.2 bar, the container empties automatically. With this setting it must be ensured that a suitable container is in place to collect the escaping condensate when drainage occurs.

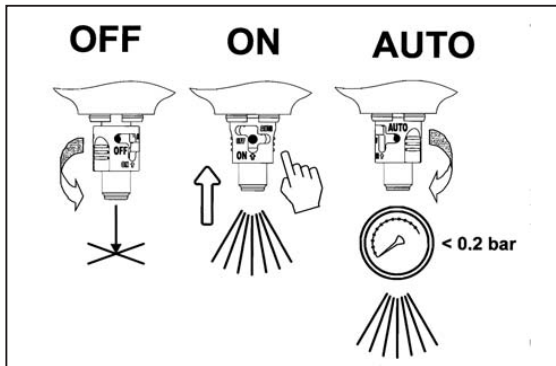

CLEANING THE FILTER ELEMENT



ATTENTION

Do not use alcohol for cleaning the service unit. Alcohol can damage parts of service unit. Transparent components must only be cleaned using soap solution.

The filter element must be cleaned once annually. For this purpose, proceed as follows:

- ▶ Drain the water.
- ▶ Shut off the main air supply and carefully allow the residual pressure to dissipate.
- ▶ Unlock the filter regulator container, turn anti-clockwise to the stop and remove.
- ▶ Unscrew the separating plate. The filter is located loosely on the separating plate centring device.
- ▶ Clean the filter element using soap solution and blow through forcefully.
- ▶ Reinstall the clean filter element and fasten the separating plate.
- ▶ Insert the filter regulator container in the housing and turn clockwise. The container locks automatically.

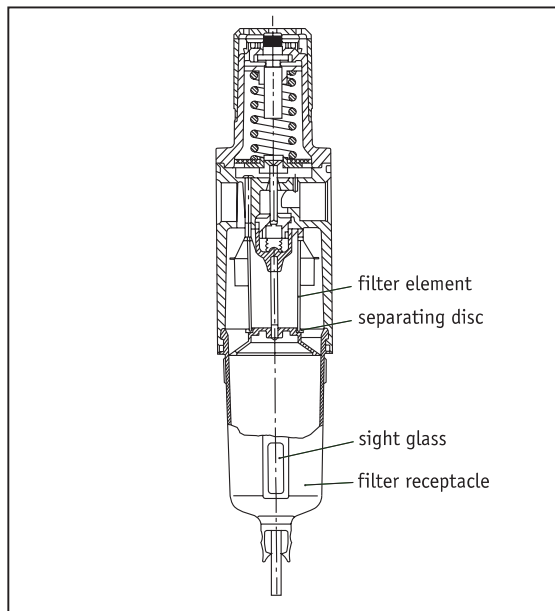

Cleaning the filter element

FILLING AND ADJUSTING OILER

The oiler ensures that the hoist air supply is consistently provided with a precisely-metered quantity of oil. Regular checking of the oiler is very important, as the vane motor may be damaged in the case of lubricant deficiency. The oiler can also be refilled under pressure.

- ▶ Check the oil level through the sight glass in the container. The oil level must not fall below the minimum mark.
- ▶ Remove the oil filler screw.
- ▶ Fill the container with oil up to the maximum mark and refit the oil filler screw.
- ▶ Check the oil drop rate at the sight glass with the motor running.
- ▶ Turn the oil throttle screw using a screwdriver until the desired number of drops per minute is achieved. Turning clockwise reduces the amount of oil; turning anti-clockwise increases the amount of oil.

Oil drop rate (lifting without load):

2 drops per minute.



ATTENTION!

Operation of service units with synthetic oils is not permissible. They must also not be connected to compressed air circuits, which are supplied by compressors lubricated with synthetic oil.



CAUTION!

J.D. Neuhaus only supplies standard spray oilers. Do not use microspray oilers as very finely secreted oil spray could adversely effect the surrounding air and therefore the respiratory system.

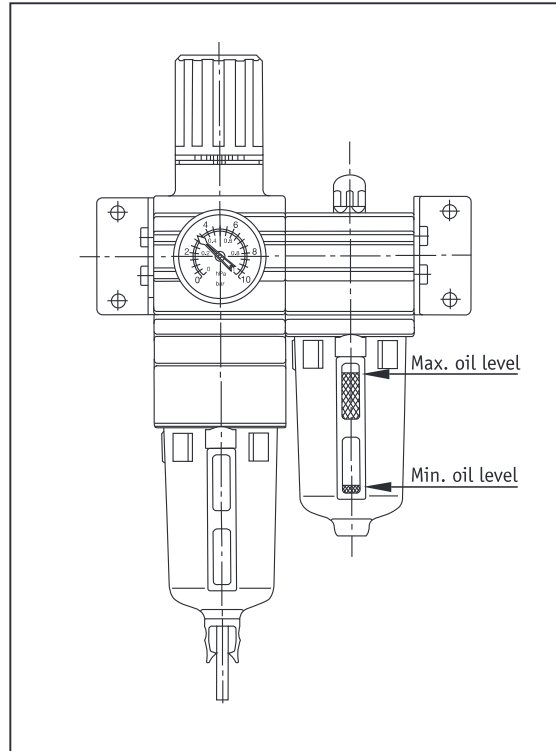

Check the oil level and top up if necessary

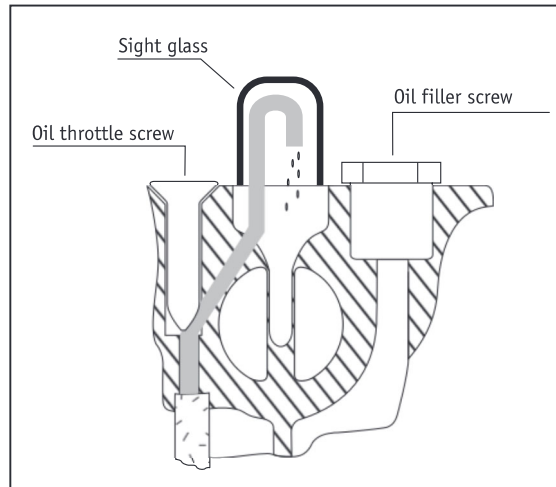

Check oil drop rate at sight glass and adjust



**MOTOR INSTALLATION/CHECKING
BRAKE LININGS AND
VANES/MOTOR LUBRICATION**

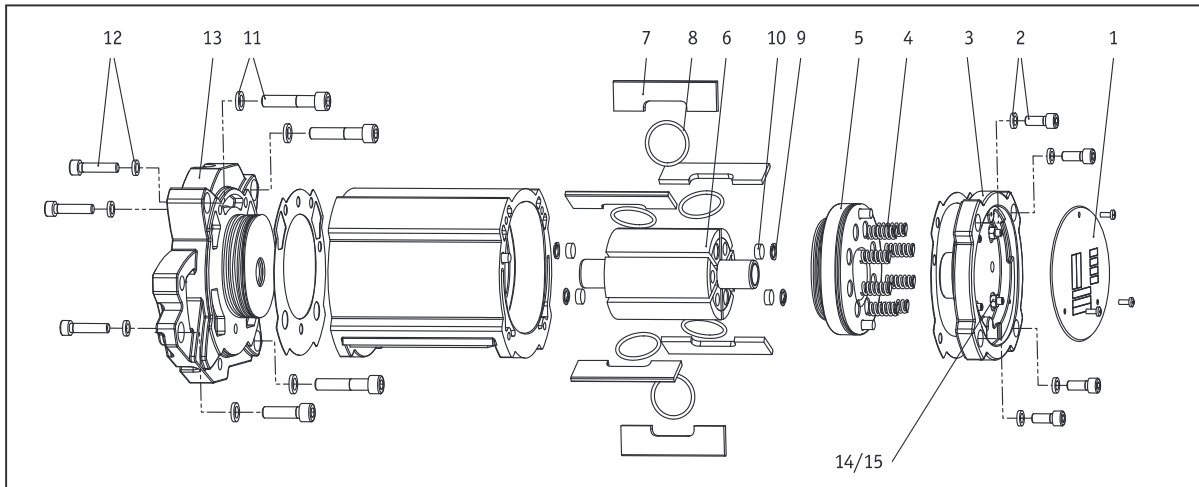

Replacing brake discs, brake piston and vanes /Motor installation

The motor and brake functions are achieved in part by means of shared components. The braking action is applied at the lateral surfaces of the rotor. The rotor is pressed via spring force from the cover-side of the motor against a second braking surface located on the opposite side by means of a piston on which braking material is bonded.

REMOVAL

The hoist must first be unloaded and disconnected from the main air supply.

Note: The following operations can be performed from the nameplate side after the motor has been removed.

- ▶ Checking vane wear, replacing the vanes with starting aids if necessary.
- ▶ Checking brake wear, replacing the brake piston if necessary.
- ▶ Renewing the motor lubrication.

The replacement of the centre section halves with brake lining is described under a separate item.

- ▶ Unscrew **1** the nameplate.
- ▶ Remove the motor cover bolts **2** and detach the motor cover **3** (when the cover bolts are removed, the brake springs **4** are fully released).

- ▶ Remove the brake springs.
- ▶ Remove the brake piston **5** from the internal cylinder integrated in the motor housing.
- ▶ Pull out the rotor **6**, removing the vanes **7** and starting aids **8**.

Checking vane wear:

(See Fig. **Checking vane wear**, page 51). When the vanes are worn, the motor power and consequently the lifting performance of the JDN Air Hoist are reduced. Replacing the vanes together with the starting aids.

Checking braking surfaces of the brake piston and the centre section half with brake lining for wear and damage:

The circular wear pattern in the braking surfaces must not be deeper than 0.2 mm (also see illustration on page 51). The extremely low-wear braking material will not reach the wear limit of 0.2 mm within the design-dependent service life of the hoist, under intended use. Should the wear limit be reached prematurely, the actual pressure must be checked with the device switched on (the brake drags in the event of insufficient pressure).

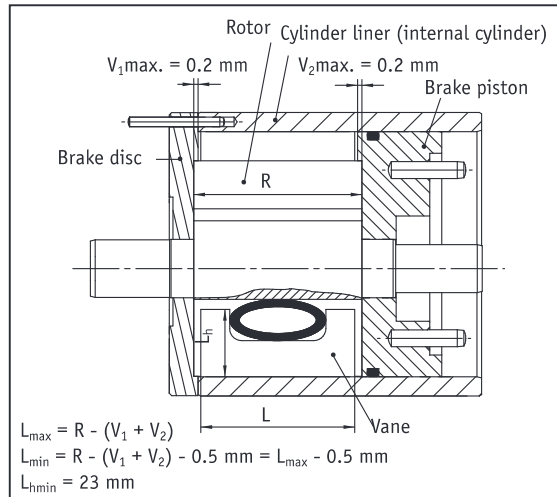

Checking vane wear

Renewing motor lubrication:

Note: The grease packing in the rotor chambers is sufficient for approx. 250 hours of normal operation. The rotor chambers are only emptied by approx. 75%. In this condition, refilling must be performed.

The retaining rings 9 and Vyon washers 10 must be removed in order to refill the chambers.

Then pack the chambers with high-performance lubricant (JDN Art. no 11901) without forming cavities.

Use new Vyon washers to close off the lubricant chambers and secure these using retaining rings.

Replace centre section halves with brake lining.

If the centre section half with brake lining is to be replaced, the following removal operation is also required.

- ▶ Detach the hoist from the point of attachment and set down carefully.
- ▶ Detach the chain box if necessary.
- ▶ Remove the control valve.
- ▶ Remove centre section bolts 11.

- ▶ Detach the motor with centre section half on the motor-side from the hoist.
- ▶ Remove the bolts 12 and pull out the centre section half with the brake lining 13.

Motor installation with additional basic lubrication:

- ▶ Apply high-performance grease lightly to braking surface and rotor bearing (needle bush) in the centre section half and slide this into the motor housing. At the same time, insert the anti-twist device (pin).
- ▶ Bolt centre section half to motor housing.
- ▶ Coat the internal cylinder of the motor housing lightly with high-performance grease.
- ▶ Coat the entire rotor lightly with high-performance grease and insert into the front rotor bearing with the clutch side first.
- ▶ Coat the vanes lightly with high-performance grease and insert into the rotor slots with the starting aids.
- ▶ Coat the braking surface and the outer diameter including the brake piston seal lightly with high-performance grease and push the brake piston with the braking surface first into the internal cylinder. Note the position of the eccentric bore.
- ▶ Insert the brake springs into the bores of the brake piston.
- ▶ Loosen adjusting bolts 14 and lock nuts 15. Screw back adjusting bolts.
- ▶ Apply high-performance grease lightly to rotor bearing (needle bush) in the motor cover and install motor cover. Ensure correct seating of the brake springs and the locating pins to the motor housing and to the brake piston. Do not tighten the four adjusting bolts after bolting the motor cover in place, only screw them in loosely by hand to the stop in the cover. Screw back the lock nuts sufficiently beforehand.
- ▶ Then screw back the adjusting bolts 45° from the stop, hold, and lock with the nuts. For lifting heights of 10 m and more, a setting of up to 60° is required. For operation in areas with ambient temperatures exceeding 30° C, the adjustment must be carried out with the device warmed up accordingly.



- ▶ Attach the nameplate.
- ▶ Push motor with centre section half on the motor side onto the hoist - install load hooks at same time - and tighten centre section bolts.
- ▶ Install the control valve.



ATTENTION!

Tightening torques, see E-list.



CAUTION!

Check the braking action of the hoist under load (run in the brake by performing several hoisting cycles, then assess) prior to initial operation. Check the motor power. In the event of low motor power, regulate the adjusting bolts again.



**REMOVING AND INSTALLING LOAD SLEEVE,
BOTTOM BLOCK, CLAMP AND BUFFER**

**REMOVING AND INSTALLING LOAD SLEEVE AND
BUFFER – SINGLE-CHAIN HOIST 1.5 TI**

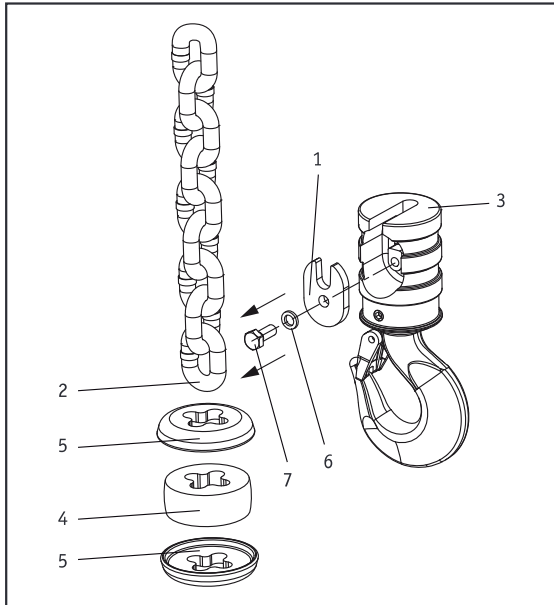

Removal

- ▶ Unscrew bolt **7** and remove it from the chain pocket together with retaining washer **6** and shaped element **1**.
- ▶ Remove the chain link **2** from the chain pocket.
- ▶ Detach the buffer **4** and buffer discs **5** from the chain.

Assembly

- ▶ Push the buffer discs (edge encloses buffer) and the buffer onto the chain.
- ▶ Insert the chain link into the chain pocket of the load sleeve (position of the weld must align with that of the following links).
- ▶ Insert the shaped element into the chain pocket, install and tighten the bolt with the retaining washer (change tightening torque to 8 Nm).

**REMOVING AND INSTALLING BOTTOM BLOCK AND
BUFFER - DUAL CHAIN HOIST (3 TI/2)**

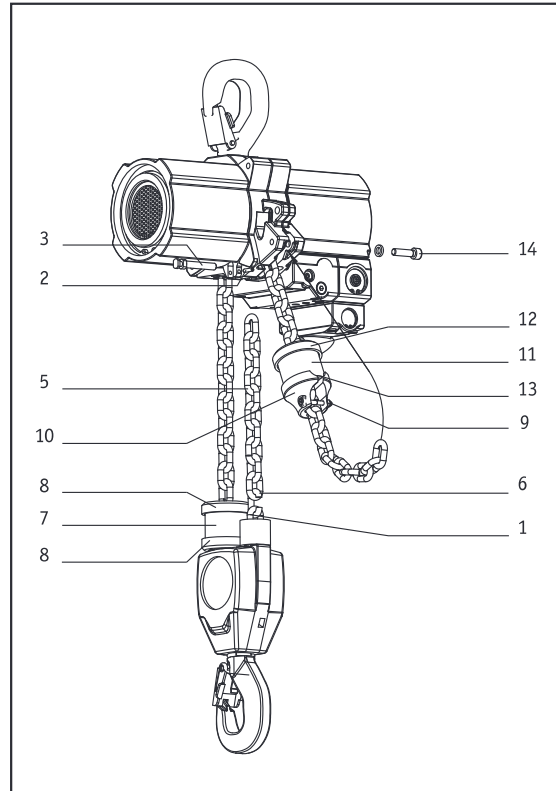

Removal

- ▶ Move the bottom block as close as possible to the hoist body.
- ▶ Position the bottom block securely in order to prevent the chain from unravelling uncontrollably causing the bottom block to fall.
- ▶ Remove the chain link **1** of the bottom block from the chain mount on the hoist body; drive out the roll pin **2** and the end chain link pin **3** for this purpose.



Note: For assembly, it is helpful to fasten a short assembly chain **5** to the end of the chain by means of an open chain link **6** before pulling the chain out of the bottom block. This assembly is pulled into the bottom block as the chain is pulled out and remains there until assembly is completed.

- ▶ Pull out the chain from the bottom block. The buffer **7** and buffer discs **8** are thereby pulled from the chain.

Assembly

- ▶ Push the buffer discs (edge encloses buffer) and the buffer onto the chain.
- ▶ Align the chain and fasten it to the assembly chain in the bottom block by means of the open chain link.
- ▶ Pull the chain through the bottom block and detach the assembly chain and the open chain link from the chain. If no assembly chains have been used, the end of the chain must be inserted into the bottom block and pulled through by turning the sprocket wheel using an auxiliary tool.
- ▶ Push the spacer pipe onto the chain.
- ▶ Align the bottom block chain and push the chain link pin through the chain link to be attached (position of the weld must align with that of the following links).
- ▶ Drive in a new roll pin to secure the end link pin.

REMOVING AND INSTALLING CLAMP AND BUFFER

Removal (see illus. page 53)

- ▶ In the case of operation with chain box, run the chain out of the chain box and detach it from the hoist.
- ▶ Remove the chain link of the idle chain from the chain mount on the hoist body. Unscrew the Allen screws **14** for this purpose.
- ▶ Loosen screw connections **9** of the clamp **10**.
- ▶ Remove the clamp from the chain.
- ▶ Detach the buffer **11** and buffer discs **12 + 13** from the chain.

Assembly

- ▶ Push the buffer disc with edge (edge encloses buffer), buffer and buffer disc without edge onto the chain.
- ▶ Insert the tenth chain link into the chain pocket of the clamp (chain pocket away from hoist body, pointing outwards).
- ▶ Introduce a screw connection to secure the chain link in the clamp.
- ▶ Align the idle chain and fasten the end chain link to the hoist body.
- ▶ Attach the chain box.



ATTENTION!

Do not twist the chain! The chain is subjected to impermissible stresses if the chain is twisted.

CHECKING CHAIN, CHAIN SPROCKET AND CHAIN GUIDES

See also **Check dimensions**, page 55. If the chain of the JDN Air Hoist displays one of the following characteristics, it must be replaced with a new one:

- ▶ Corrosion pitting
- ▶ Bent or damaged chain links
- ▶ Chain drawn tight
- ▶ Wear over 11 pitches (A_{max})
- ▶ Single pitch wear (B_{max})
- ▶ Elongation of a single link (D_{max})

Check the entire length of the chain.

Please observe the information contained in DIN 685, part 5 when checking chains. For further instructions see ISO 7592.

CHECK DIMENSIONS

HOIST CHAIN

Note: When checking the replacement limit, future wear up until the next inspection date must be taken into account. If the chain dimension values are outside the limit values specified in the table when checked, the chain has reached its replacement limit and must be replaced by a new one. The chain sprockets must also be replaced together with the chain, as otherwise the new chain will be subjected to increased wear. Each chain replacement must be documented in the inspection log.

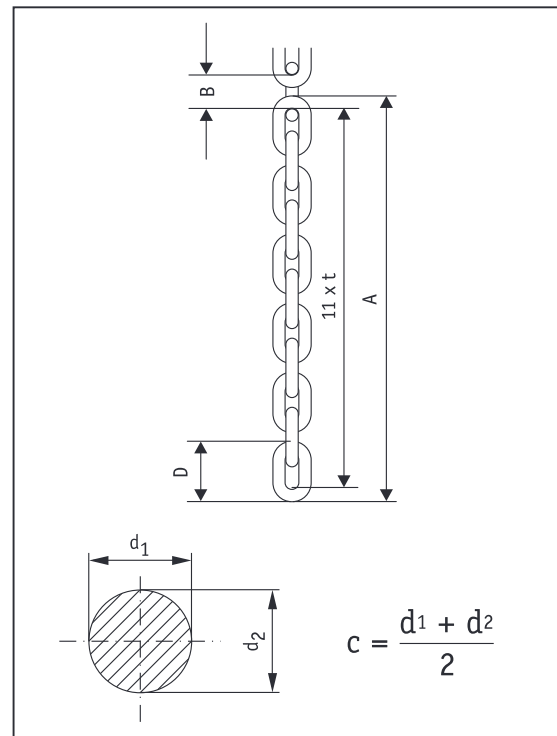

Check dimensions of hoist chain

Chain d x t	9 x 27
Dimension A max. 11 x t inside max.	320.5 303.2
Dimension B max.	28.4
Dimension C min.	8.1
Dimension D max.	46.4

Dimensions in mm



LOAD HOOK

If the measured distance **y** and the height **h** of the load hook are outside the wear limits, the hook must be replaced.

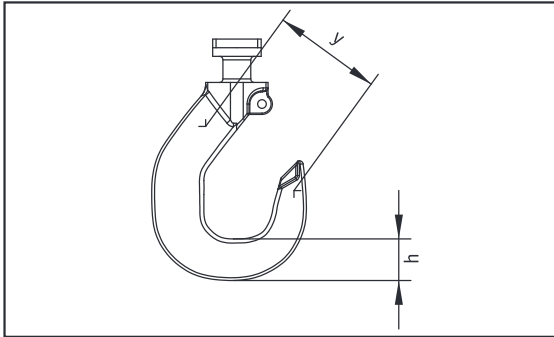

Check dimensions of load hook

Type	Permissible maximum dimension of measured distance "y"	Permissible minimum dimension of height "h"
PROFI 1.5 TI		
Load sleeve	57.8	28.2
Centre section	63.0	36.1
PROFI 3 TI/2	63.0	36.1

Dimensions in mm

WEAR DIMENSIONS FOR CHAIN SPROCKETS

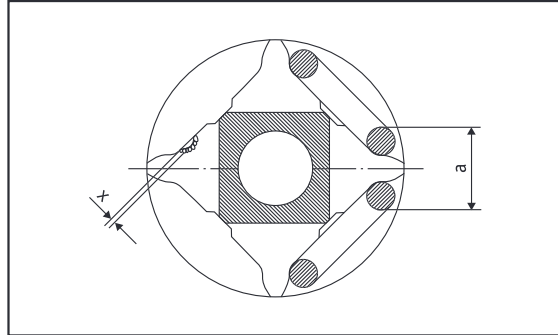

Wear dimensions for chain sprockets

Chain size d x t mm x mm	z (1)	a mm	x mm
9 x 27	4	25	0.2

a, x = Limit dimensions after maximum permitted wear

z = Number of teeth of the chain sprocket

d x t = Nominal diameter times pitch of chain link

WEAR DIMENSIONS FOR CHAIN GUIDES AND HOOK MOUNTS

Check the chain guides for wear and when the wear dimension of 1 mm is reached with regard to chain guide diameters or hook mounts in the centre section of the device: Replace the housing.

The wear dimension must be measured at the points on the guide surfaces which have been worn down by the chain.



CHECKING AXIAL PLAY

Maintenance and lubrication

Please ensure that load hooks and/or load eye mounts are regularly checked, at least once a year. **Especially important:** in areas where wear-promoting conditions such as high ambient temperatures or corrosive substances in the atmosphere are present, or where lubricants may be washed out, **the frequency of maintenance and inspection intervals must always be increased.**

HAZARDS IN THE CASE OF INSUFFICIENT MAINTENANCE/LUBRICATION



DANGER!

In the event of insufficient maintenance/lubrication the extent of wear may be so high that there is a danger of loads falling.

PREVENTION OF DANGERS

Dangers are avoided by regular maintenance/lubrication in suitable intervals.

When the axial play of the installed hook or load eye exceeds the maximum play specified, the worn parts must be replaced.

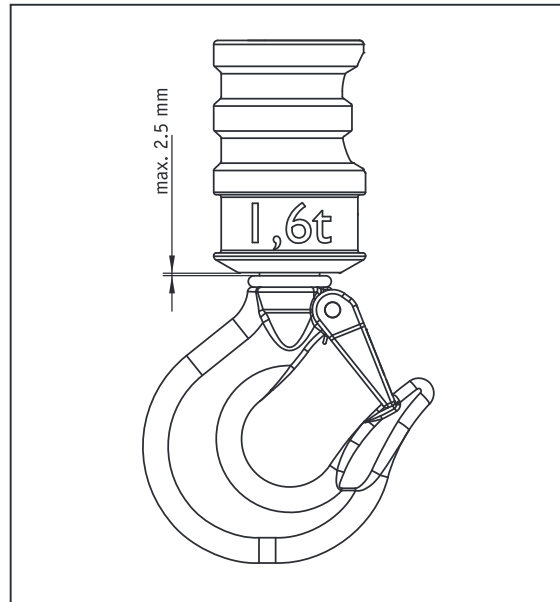

Load sleeve with load hook or load eye

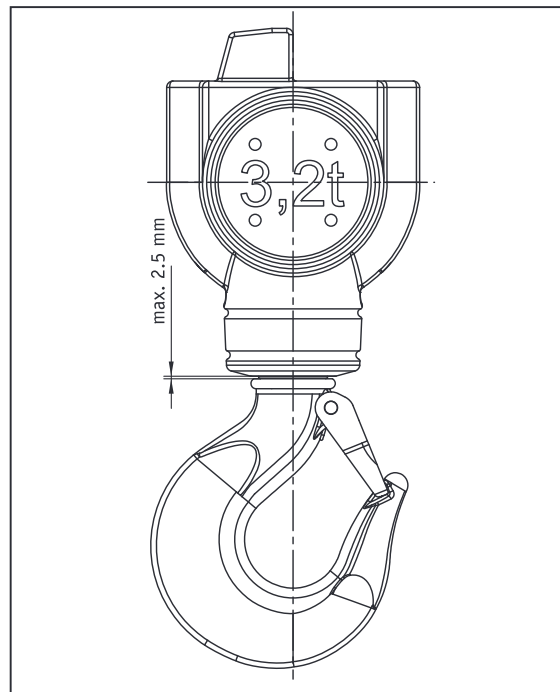

Bottom block with load hook or load eye



REMOVING AND INSTALLING CHAIN



ATTENTION!

The chain supplied together with this JDN hoist is matched to the chain sprocket according to strict tolerances. In order to ensure optimum function of the chain and in order to prevent hazards, only genuine JDN chains must be installed.

Note: When a chain is replaced, the buffers must also be replaced. For changing buffers at the chain ends, see section **Removing and installing load sleeve, bottom block, clamp and buffer**.

Buffers not located on the chain ends are most easily replaced when the open chain link between the old and new chains passes the buffer to be replaced.



ATTENTION!

Do not twist the chain ends.

- ▶ In the case of operation with chain box: switch the hoist in the “lower” rotational direction and run the old chain out of the chain box. Then remove the chain box.
- ▶ Move the bottom block as close as possible to the hoist body and position it securely.
- ▶ Detach the idle chain from the chain mount on the hoist body (see also section **Removing and installing load sleeve, bottom block, clamp and buffer**).
- ▶ Detach the clamp, buffer and buffer discs from the end of the idle chain. **For single chain hoists** also detach the load sleeve, buffer and buffer discs from the load chain. **For dual chain hoists** detach the bottom block chain from the hoist body (see also **Removing and installing load sleeve, bottom block, clamp and buffer** section).

- ▶ Attach the new chain to the end link of the load section of the old chain after aligning the welds and the first chain link by means of an open chain link. The welds on the upright chain links must face outwards when running over the chain sprockets. If the first link of the new chain is not correctly positioned, it must be removed.

Note: It is possible that the first chain link of the other chain end is correctly positioned. Switch the hoist to the “lift” rotational direction. The new chain will now run into the hoist while the

- ▶ old chain is simultaneously run out on the idle chain side.

Run the chain until the join between the old and new chain has run sufficiently (approx. 1 m) out of the centre section on the idle chain side.

- ▶ Detach the connection between the old and new chains.
- ▶ Install the clamp (at the 10th chain link), buffer and buffer discs on the idle chain section of the new chain.

Align the idle chain and attach to the fastening point on the hoist (see also **Removing and installing load sleeve, bottom block, clamp and buffer** section)

- ▶ Attach the chain box if necessary.
- ▶ Switch the hoist in the “lift” rotational direction until the as yet free end of the **aligned** load chain is the correct length for attaching the chain link
 - **for single chain hoists** in the load sleeve after the buffer and buffer discs have been pushed on,
 - **for dual chain hoists** at the fastening point of the hoist body (see also **Removing and installing load sleeve, bottom block, clamp and buffer** section).

Note: If the chain link of the load chain is positioned incorrectly, it must be removed, the following chain link will be positioned correctly.



REPLACING CHAIN AND CHAIN SPROCKET

Note: If the chain jams in the hoist and can no longer be run out, the gearbox must be dismantled (see spare parts list for "Gearbox").

For dual chain hoists, when removing the old chain, an assembly chain **1** is brought into position on the deflection sprocket of the bottom block by means of an open chain link (see also **Removing and installing load sleeve, bottom block, clamp and buffer** section and **Removing and installing chain** section).

Following replacement of the chain sprocket (see spare parts list) an assembly chain **2** is run carefully – with low air pressure – over the drive sprocket.

Fasten the new chain **5** to the assembly chain on the drive sprocket by means of one or two open links **3** to the idle chain side. The first chain link **4** must run upright over the drive sprocket with the weld facing outwards.

Switch the hoist to the "lower" rotational direction and detach the assembly chain from the chain after it comes out of the centre section.

For dual chain hoists, the new chain, after it has been aligned, is pulled over the deflection sprocket of the bottom block using the assembly chain.

Note: If the chain link on the idle chain side is positioned incorrectly, it must be removed, the following chain link will be positioned correctly.

Fastening of the chains and installation of the load sleeve, clamp, buffer and buffer discs is carried out in accordance with the **Removing and installing load sleeve, bottom block, clamp and buffer** section and the **Removing and installing chain** section.

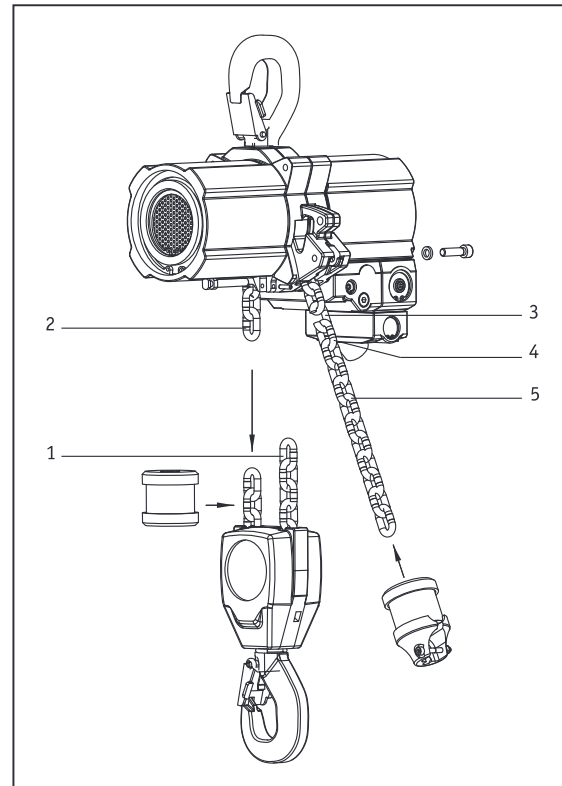

Drawing in the chain

OVERLOAD PROTECTION

The PROFI 1.5 TI and 3 TI/2 hoists are equipped with a new type of safety clutch as standard. This prevents loads exceeding the limit values set from being lifted. The limit value is set so that loads of 125 % of the load carrying capacity cannot be lifted. 110 % can be lifted in order to perform the dynamic overload test.



ATTENTION!

The safety clutch must only be engaged for a short time in order to prevent unnecessary wear and overheating of the drive.

When the safety clutch is activated, the hoist should be unloaded by switching to a lowering movement.

The overload protection can also be activated when moving at full unloaded speed against a load to be lifted, even when it is below the load size set. We therefore recommend tensioning the slack chain before lifting the load.

ADJUSTING OVERLOAD PROTECTION

The adjustment method described here is based on the attachment of test loads.



DANGER!

If the overload protection is set too high, impermissibly high stresses may arise if a load exceeding the permissible load carrying capacity is attached.

- ▶ Unload the hoist.
- ▶ Detach the gearbox cover **1** from the gearbox in order to gain access to the threaded pins **2** with lock nuts **3** located behind it.

CORRECTING THE SET LIMIT VALUE

- ▶ Loosen the lock nuts. It must be ensured that the threaded pins **are not turned**.
- ▶ During each readjustment, adjust the threaded pins to the same degree in order to adjust the disc springs evenly: turning clockwise – limit value is increased, turning anti-clockwise – limit value is reduced.
- ▶ Secure threaded pins with the lock nuts. Do not turn the threaded pins any more as the setting will be altered.
- ▶ Check the limit value for correct setting.
- ▶ Install the gearbox cover.

RESETTING THE LIMIT VALUE

- ▶ Loosen the lock nuts. Screw out the threaded pins – anti-clockwise – until the disc springs **4** are completely free of pre-tension.
- ▶ Then loosely screw in the threaded pins by hand – clockwise – to the stop, unscrew the lock nuts sufficiently far back beforehand.
- ▶ The limit value for reaching at least 110% of the load-carrying capacity is set at approx. 2.5 turns. Screw in the three threaded pins successively in small steps by approx. 1/2 turn. With this pre-adjustment after re-assembly, first let the safety clutch take effect for approx. 5 seconds (load hook on the upper end position with the motor running).

Then let the load hook run for approx. 10 seconds without a load so that the outlet air cools the clutch down.

- ▶ Secure threaded pins with the lock nuts. Hold the threaded pins tightly in the process.
- ▶ Check the limit value for correct setting, correct if necessary.
- ▶ Install the gearbox cover.
- ▶ The adjusting and inspection result arrived at by qualified personnel must be entered in the lifting gear inspection log (limit value: see **Overload protection**, page 36).

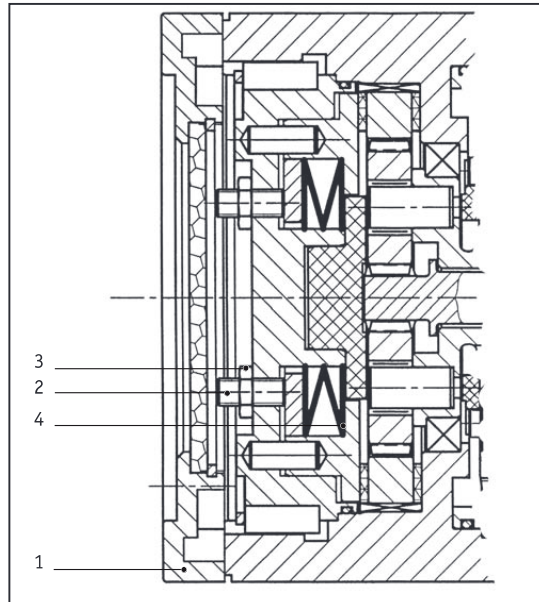

Gearbox 1.6 t



FAULTS, CAUSE AND REMEDY

FAULT TABLE

Fault	Possible cause	Remedy
Lifting not possible	Overload protection has caused deactivation	Lower hook briefly, limit load to permissible load carrying capacity, then lift again. If loads within the load carrying capacity range are not lifted, the overload protection must be adjusted. Set the air pressure correctly. Air pressures which are too high can cause deactivation within the load carrying capacity range.
	Air pressure too low	Increase air pressure to the required value
	EMERGENCY STOP button is pressed	Release the EMERGENCY STOP button once the danger has been rectified
	Hand control is faulty	Have hand control repaired
Only very slow lifting possible	Brake does not release fully	Set air pressure to the relevant value, check seal of brake piston and change seal if necessary. Check the adjustment of the brake piston (see E-list)
	Brake lining worn or uneven	Replace brake lining
	Motor cover bolts loose	Tighten the bolts
	Air supply hoses leaking or loose	Check connections of air supply hose and control hoses and connect properly
	Cross section of air line too small	Use air line with sufficiently large cross section (check air pressure)
	Dirt in the service unit*, filter blocked	Clean the service unit Ensure better air quality
	Silencer is clogged	Replace or clean silencer elements, improve air quality if necessary
	Motor vanes worn	Replace motor vanes
	Motor has run dry	Lubricate motor, check oiler*
Control valve on motor	Have control valve repaired	
Excessive running on during braking	Replace brake disc and/or brake piston worn	Replace brake disc and/or brake piston
Loud chain noise on the chain sprocket	Chain dry Chain worn	Lubricate chain Replace chain with a new JDN Chain
	Chain sprocket worn	Replace chain sprocket, check chain guide, replace if necessary
	Wrong chain drawn in	Identify chain and replace with JDN Chain if necessary
Lifting or lowering speed declines with high lifting heights or the motor comes to a standstill	Brake piston setting too tight	Correct adjustment of brake piston. At high ambient temperatures, perform adjustment with the device warmed up accordingly.

*if fitted



ACCESSORIES

FILTER SILENCER

With the use of a filter silencer, oil aerosols can be avoided and noise insulation improved:

- ▶ 99.9 % of oil aerosols during oil lubrication of the motor are absorbed by the filter element.
- ▶ The noise insulation reduces noise levels by 3 to 4 dB (A) compared with the standard silencer (sinter plate).

The ambient temperature must not be lower than -10°C .

MAINTENANCE OF FILTER SILENCER

The filtered oil runs into the transparent collecting container 3. This container must be emptied before the fluid level reaches the filter element.

- ▶ Turn the drain valve 4 90° and allow the fluid to drain out.
- ▶ Close the drain valve.

The filter must be replaced after approx. 2500 hours of operation.

- ▶ Turn the collecting container 3 slightly and detach.
- ▶ Unscrew the filter element 2.
- ▶ Insert a new filter element, with sealing ring 1 and push on collecting container until it engages.

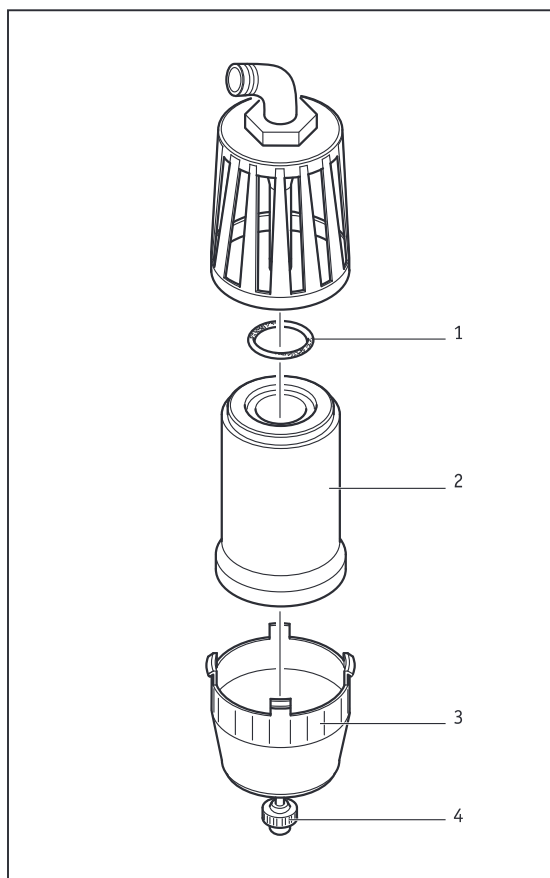

Filter silencer

BOOSTER UNIT

In the event of a control hose length exceeding 10 m, the reaction times of the pushbutton controls increase significantly.

Consequently, a booster unit is generally installed on the motor for controls E, F and FI, enabling normal reaction times.

The operating temperature range is from 0°C to 80°C .

CHAIN BOX

For various areas of application, a chain box enhances operational safety, i.e. when a chain which is hanging down could become caught up with the load.

JDN chain boxes are available in various sizes, corresponding to the chain lengths.



ATTENTION!

Do not exceed the permissible filling capacity. Danger of chain falling.



ATTENTION!

Loads must not be moved against the chain box during lifting. If necessary, attach a clamp to the chain.

The clamp must be attached above the load hook so that it functions as a preliminary end stop. With the PROFI 2 TI (dual chain) the clamp must be positioned as far as necessary downwards on the reeved chain in order to support the bottom block (stationary chain). In addition, a spacer must be attached to the opposite (moving) chain above the buffer in order to relocate the load hook stroke limiter. Please contact us, if required.

For greater clarity, see the illustration on the right on page 53.

In all cases, a clamp is attached in the 10th chain link of the unloaded chain end so that a length of chain remains in the chain box when the bottom load hook position is reached. Thus, the chain cannot run next to the chain box during subsequent lifting (see section **Removing and installing chain** page 58).

Depending on the ratio of the size of the hoist (without running gear) and the chain box, the chain box may have to be stabilised by the customer due to an acceptable vertical hoist position. This is facilitated by a suspension point on the rear of the box. We will be happy to answer any questions on this matter.

Modifications may only be made to the chain box on agreement with J.D. Neuhaus GmbH & Co. KG.



ATTENTION!

Never allow the chain to pile up in the chain box.

The chain must only enter the container via the chain drive. If it falls out of the container, e.g. during transportation, it must be run out completely on the load hook side and then run back into the container via the chain drive, in the air hoist operating position.

- ▶ After installing the chain box, lower the load hook to the bottom position once.
- ▶ Then activate lifting movement and run the complete chain into the chain box.



DANGER!

When operated with a chain box, lubrication of the chain is particularly important in order to prevent it from piling up and falling out. Do not install longer chains when changing chains.

Furthermore, hazards arise due to rusty chains when operating with chain boxes, as the chain can form a heap and fall over the edge of the container rim. In addition, rusty chains are subject to extreme wear.

If the hoist has been transported with the chain in the chain box, the chain box must be emptied manually before initial operation (if necessary, remove the chain box from the hoist). The entire chain must then be allowed to run to the load side and, subsequently, be driven back into the chain box. The hoist must be kept in a hanging position during this procedure. This process will ensure that the chain does not lock when loads are being lowered.



APPENDIX

TECHNICAL DATA

JDN PROFI TI AIR HOISTS

Type		1.5 TI	3 TI/2
Air pressure	bar	4 to 6	4 to 6
Load-bearing capacity	t	1.6	3.2
Number of chain sections		1	2
Motor power	kW	1.3 to 2	1.3 to 2
Lifting speed at nominal load	m/min	4 to 6	2 to 3
Lifting speed without load	m/min	8.4 to 10	4.2 to 5
Lowering speed at nominal load	m/min	11 to 12	5.5 to 6
Air consumption at nominal load, lifting	m ³ /min	1.5 to 2.6	1.5 to 2.6
Air consumption at nominal load, lowering	m ³ /min	2.2 to 3.6	2.2 to 3.6
Air connection	G 1/2	G 3/4	G 3/4
Hose dimension (Ø inside)	mm	19	19
Weight for standard lift, rope control	kg	56	66
Chain dimensions	mm	9 x 27	9 x 27
Weight for 1 m chain	kg	1.8	1.8
Standard lift	m	3	3
Control length for standard liftm		2	2
Noise pressure level with nominal load ¹ with standard silencer - lifting	dB(A)	73 to 77	73 to 77
Noise pressure level with nominal load ¹ with standard silencer - lowering	dB(A)	78 to 80	78 to 80

¹ measured from 1 m distance according to DIN 45635 part 20



DIMENSIONS

JDN PROFI TI AIR HOISTS

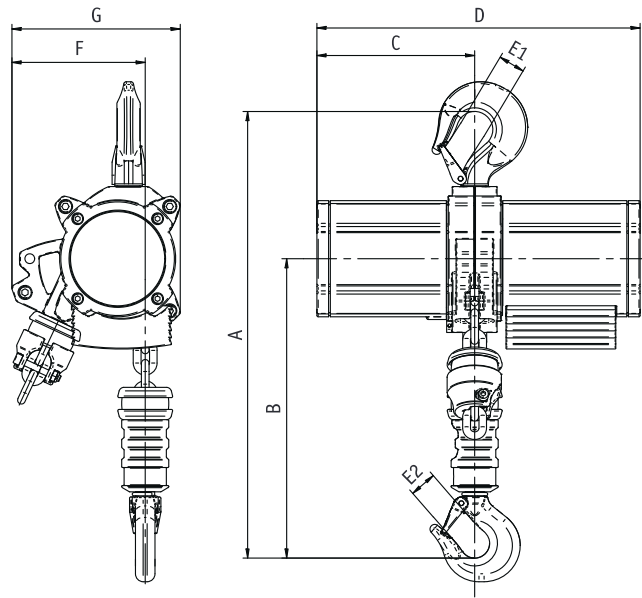

Type		1.5 TI	3 TI/2
A minimum headroom*		480	544
B	mm	293	356
C	mm	200	200
D	mm	412	412
E ₁	mm	28	28
E ₂	mm	26	28
F to centre of hook, without chain box	mm	170	140
G maximum width	mm	215	215

*Chain boxes increase the required headroom

CIRCUIT DIAGRAM

**ROPE CONTROL,
WITHOUT MAIN AIR EMERGENCY STOP VALVE**

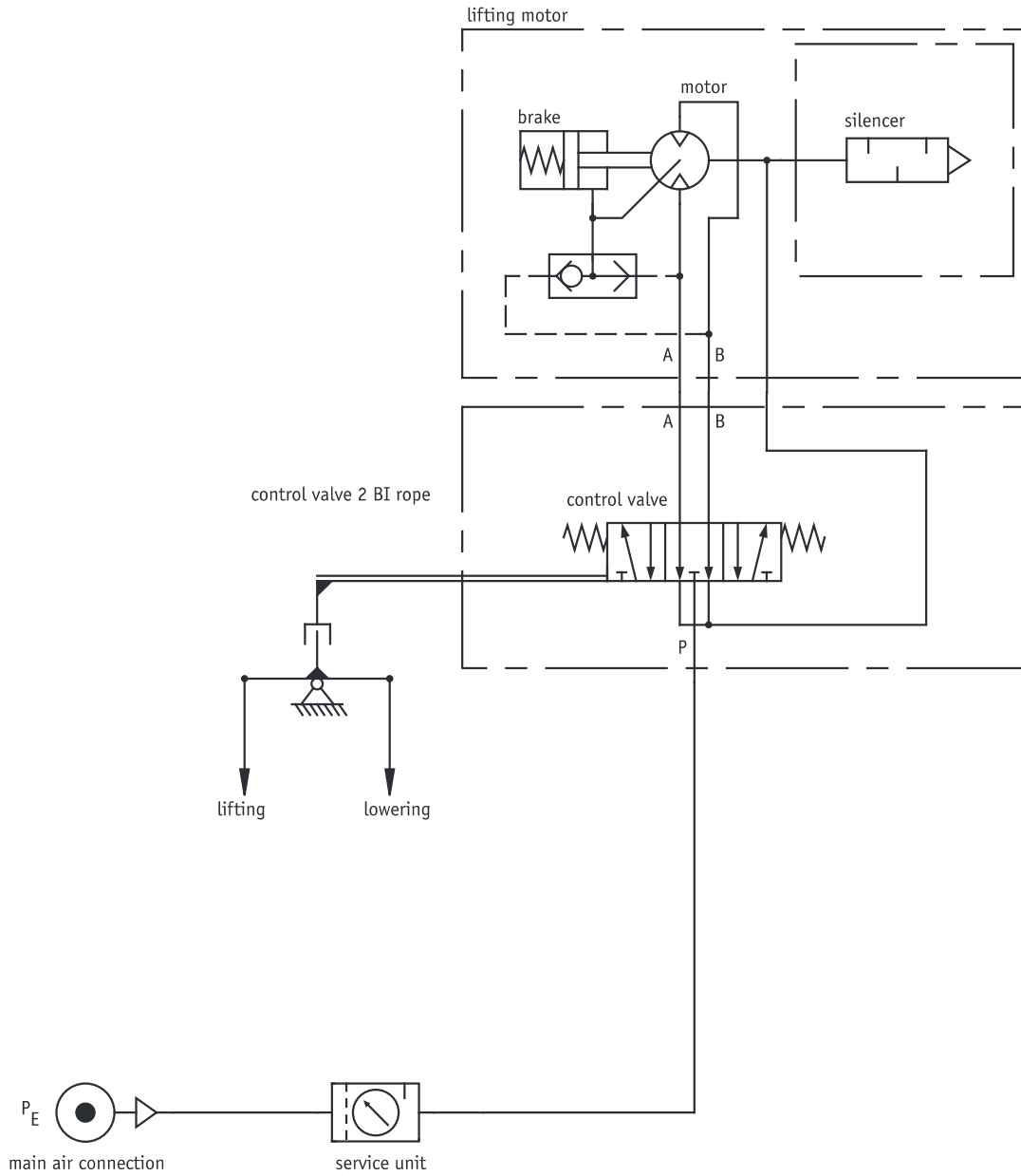

CIRCUIT DIAGRAM

**E-CONTROL, DUAL-FUNCTION,
WITHOUT EMERGENCY STOP DEVICE
WITHOUT MAIN AIR EMERGENCY STOP VALVE
(NOT FOR EEA)**

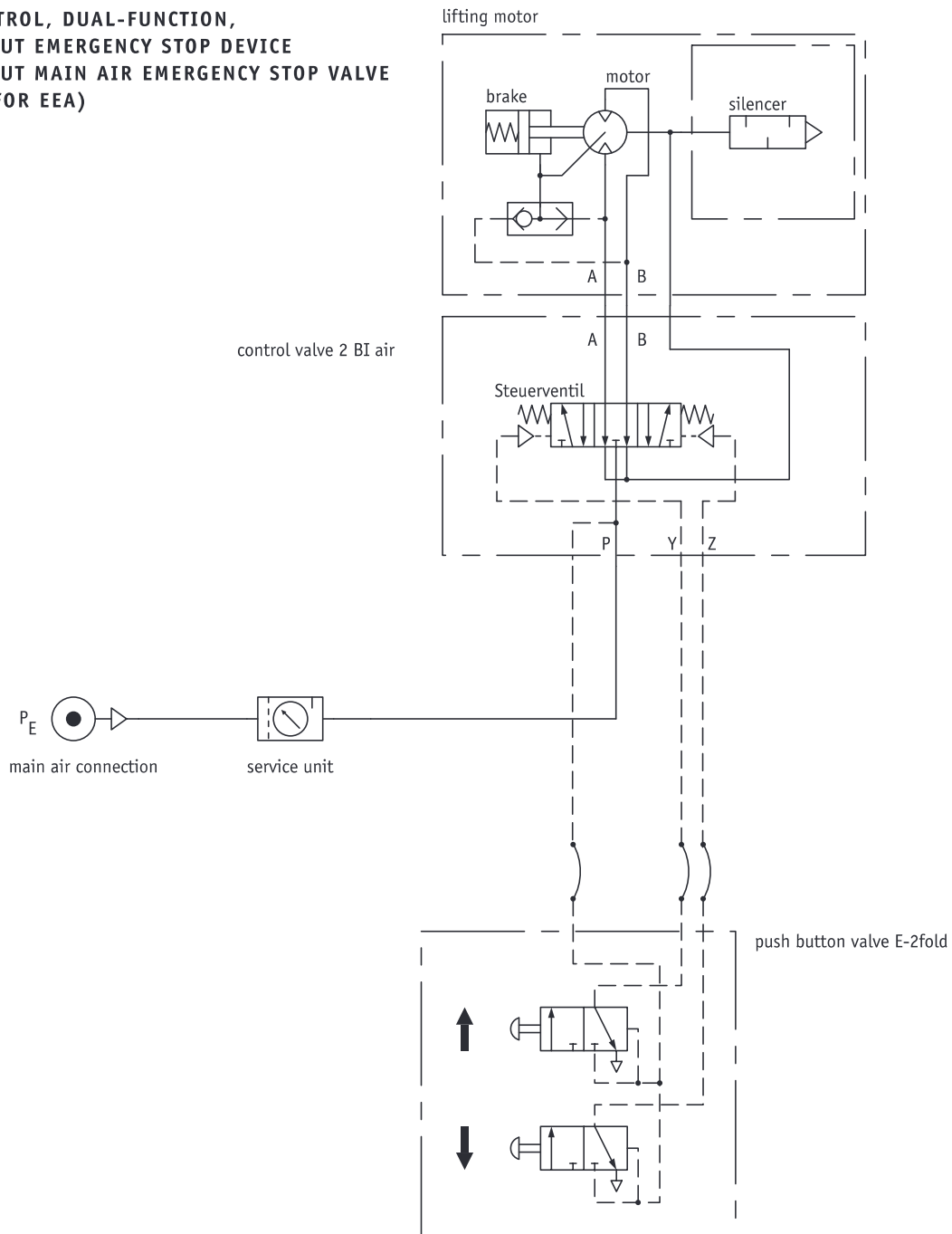

CIRCUIT DIAGRAM

**E-CONTROL, DUAL-FUNCTION,
WITH EMERGENCY STOP DEVICE
WITH MAIN AIR EMERGENCY STOP VALVE**

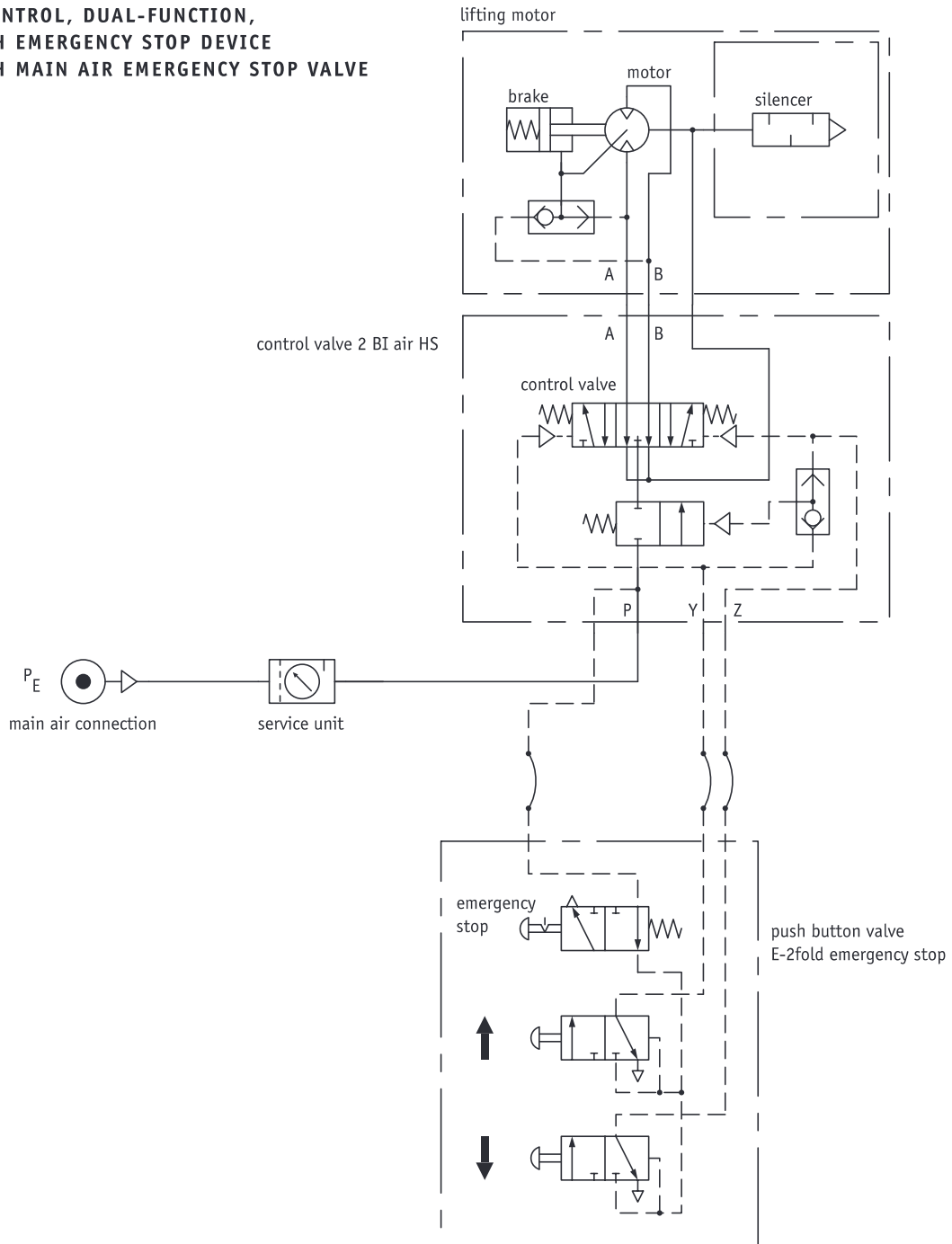

CIRCUIT DIAGRAM

**E-CONTROL, 4-FUNCTION,
WITHOUT EMERGENCY STOP DEVICE
WITHOUT MAIN AIR EMERGENCY STOP VALVE
(NOT FOR EEA)**

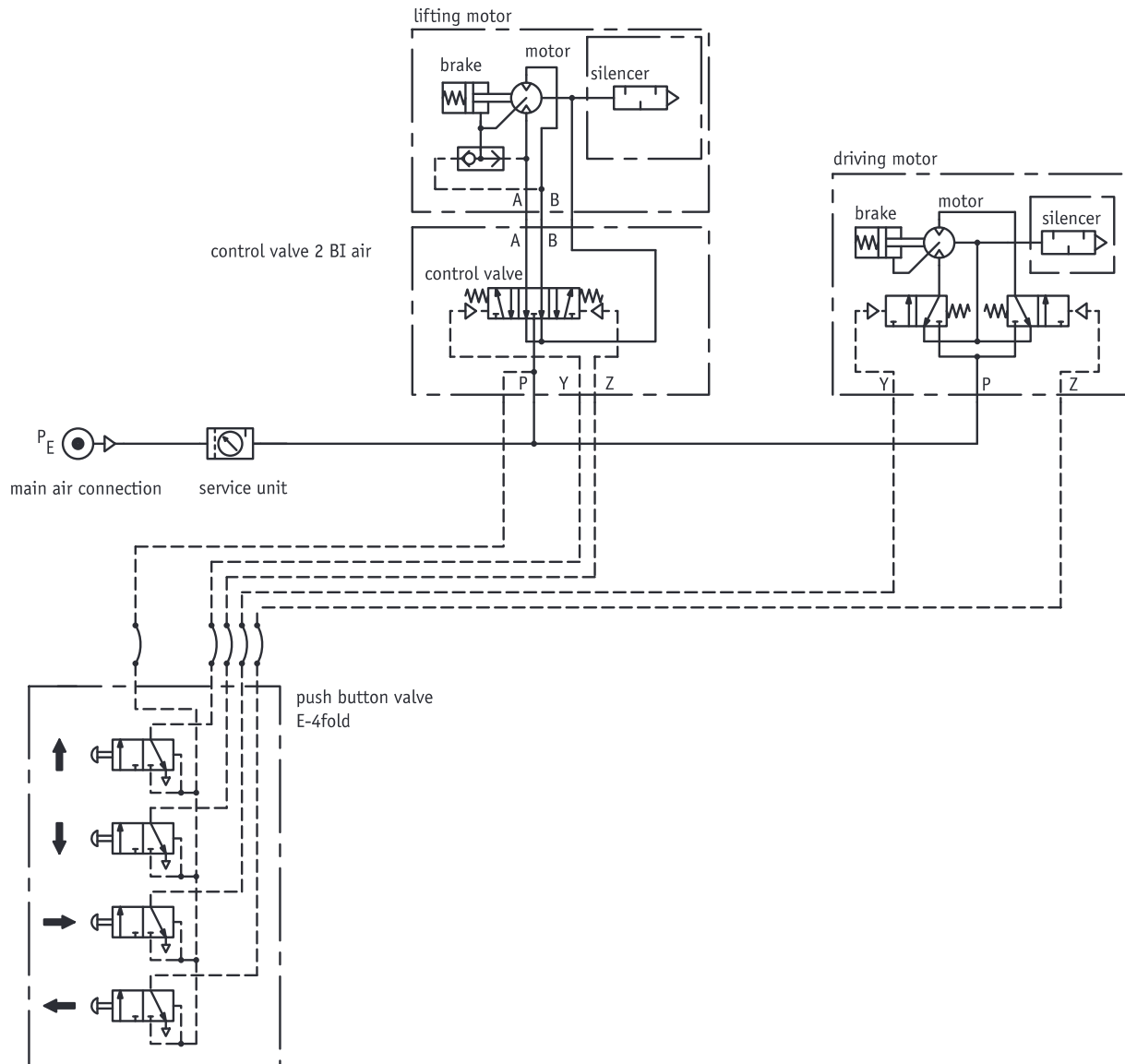

CIRCUIT DIAGRAM

**E-CONTROL, 4-FUNCTION,
WITH EMERGENCY STOP DEVICE
WITH EXTERNAL MAIN AIR
EMERGENCY STOP VALVE**

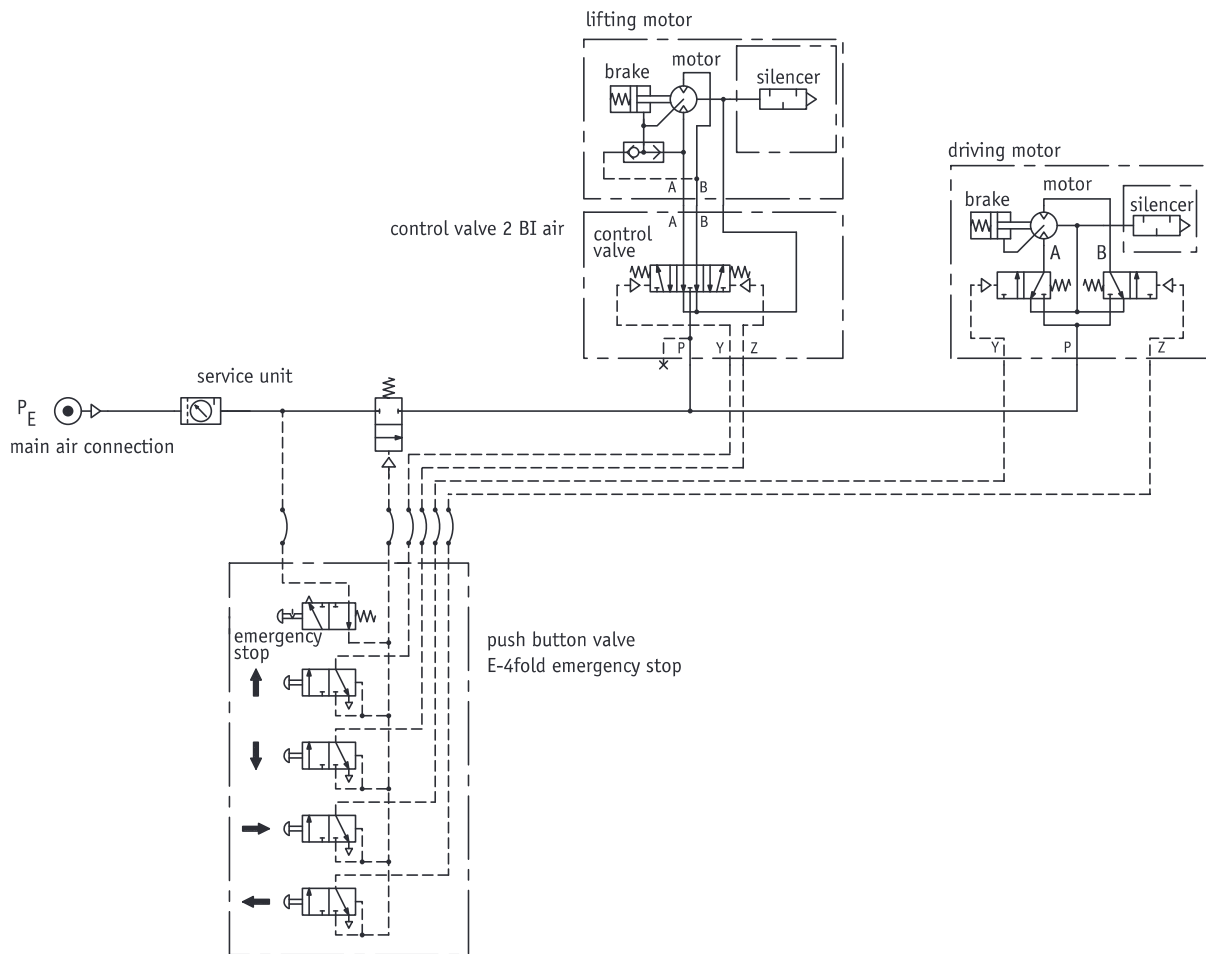

CIRCUIT DIAGRAM

**FI-CONTROL, DUAL-FUNCTION,
WITH EMERGENCY STOP DEVICE
WITH MAIN AIR EMERGENCY STOP VALVE**

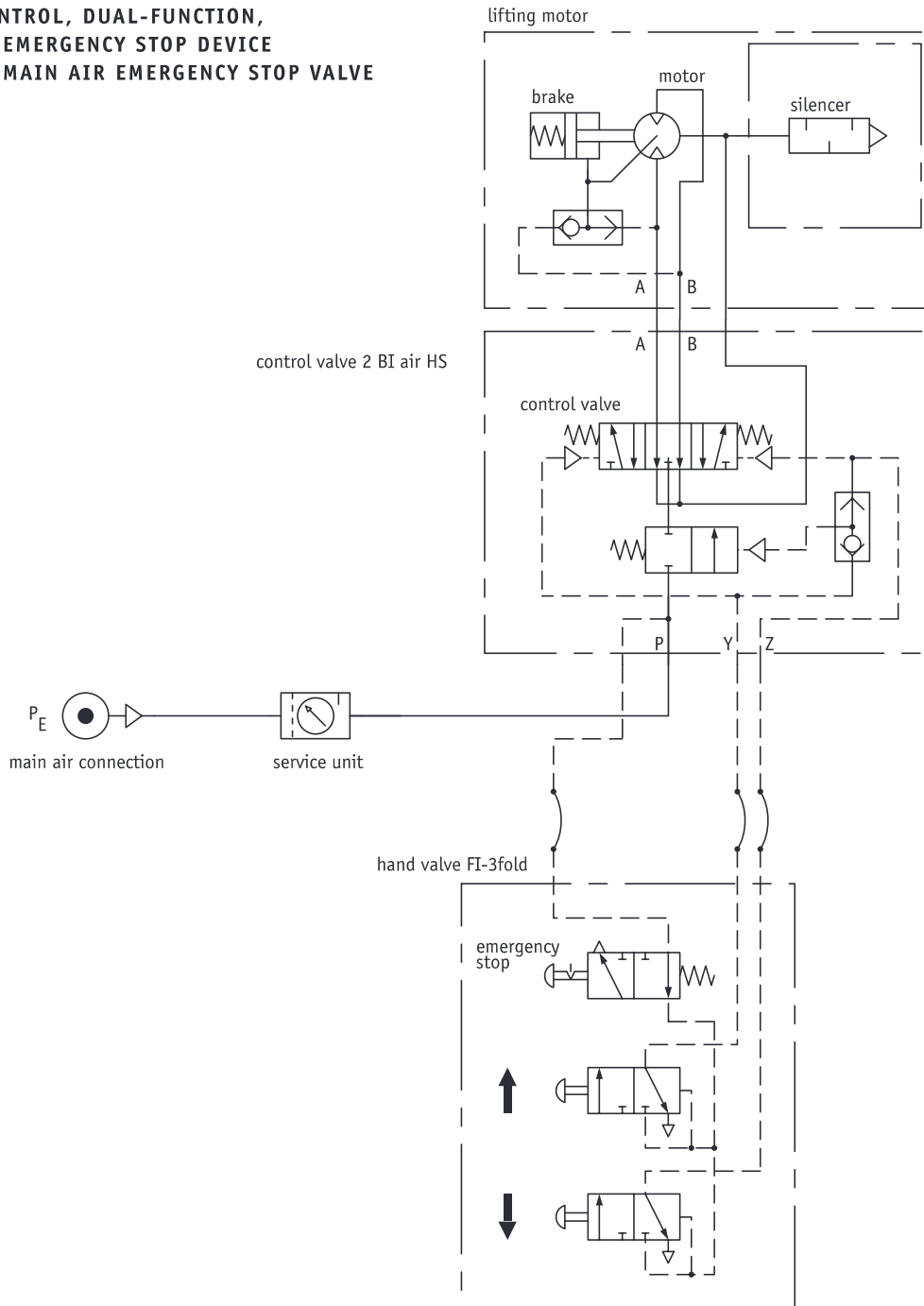

CIRCUIT DIAGRAM

**F-CONTROL, 5-FUNCTION
(DEVICE WITH TROLLEY),
WITH EMERGENCY STOP DEVICE,
WITH EXTERNAL MAIN AIR
EMERGENCY STOP VALVE**

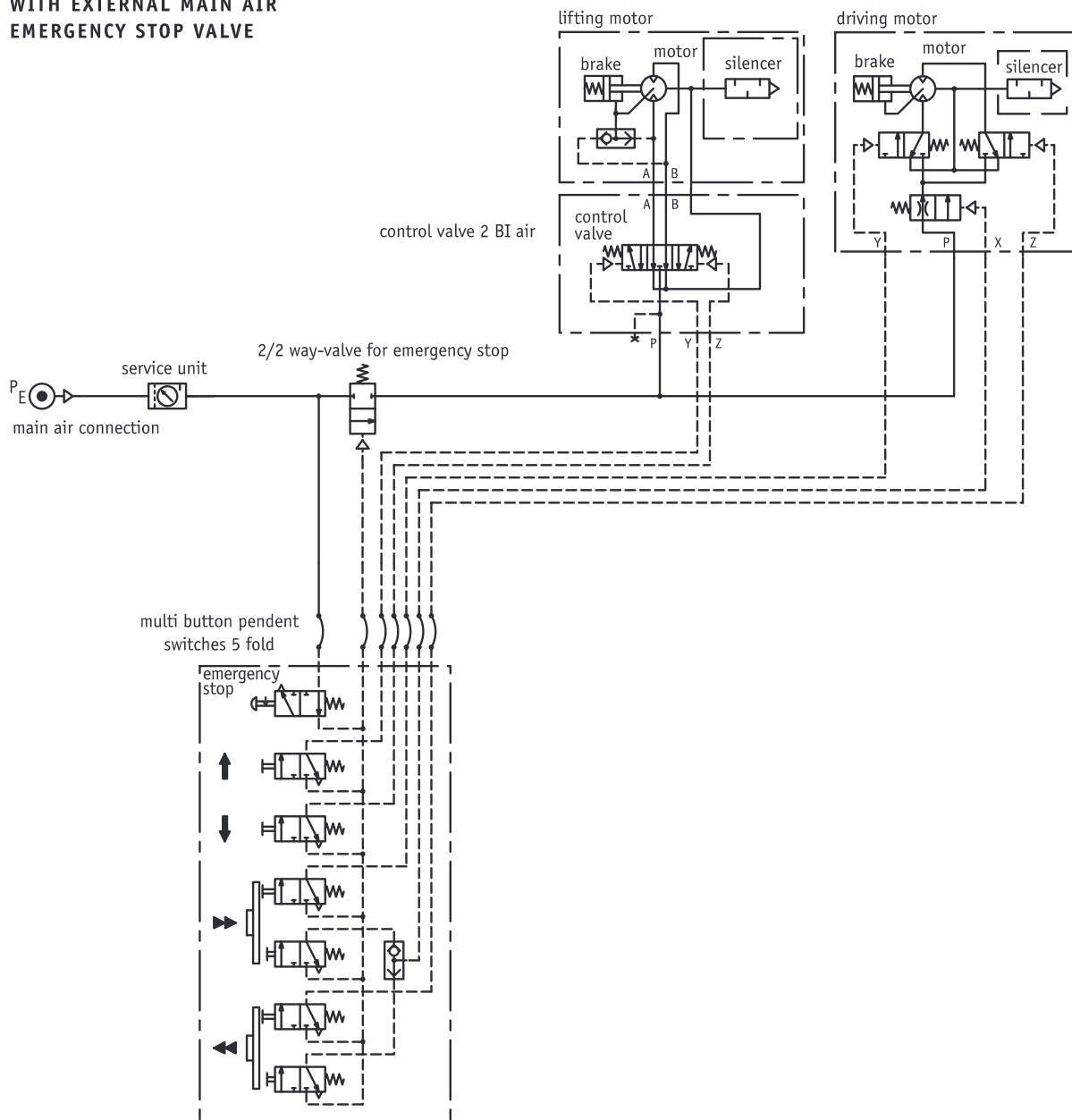

CIRCUIT DIAGRAM

**F-CONTROL, 7-FUNCTION (DEVICE WITH TROLLEY CRANE),
WITH EMERGENCY STOP DEVICE
WITH EXTERNAL MAIN AIR EMERGENCY STOP VALVE**

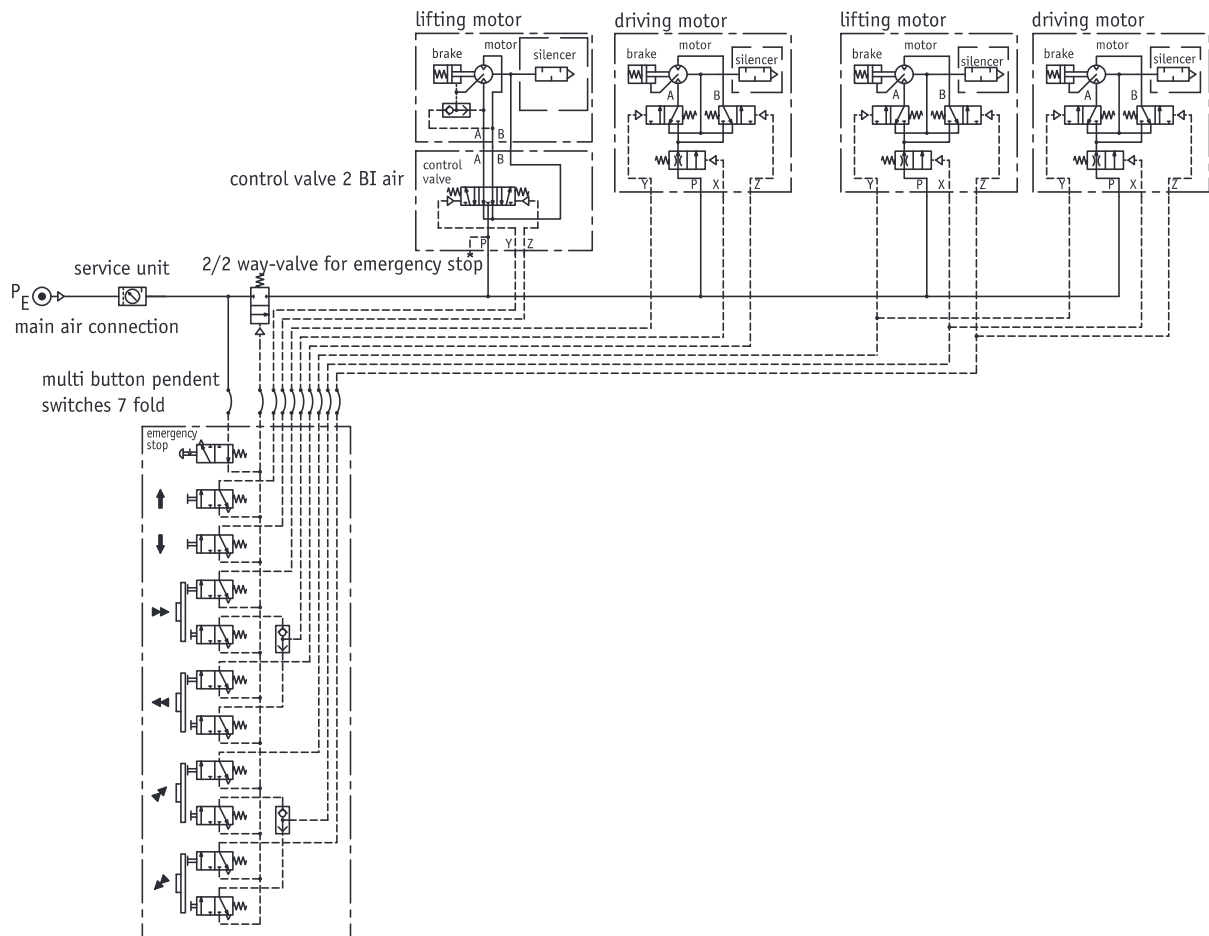

PROFI TI® is a registered trade mark of our company.
BA 820 GB · Subject to changes · 122009

J.D. Neuhaus GmbH & Co. KG / D-58449 Witten-Heven
Phone: +49 2302 208-0 / Fax: +49 2302 208-286
web site: www.jdn.de / e-mail: info@jdn.de



J. D. NEUHAUS
powered by air !