

**JDN OPERATION MANUAL
AIR HOISTS "B" AND "M"**



J. D. NEUHAUS

powered by air
powered by air

This manual edition 11/2002 covers the operation of the following JDN Air Hoists:
Please fill in here the Fabr.-No. of your JDN Air Hoist.

B24

Fabr.-No.

B48

Fabr.-No.

B612

Fabr.-No.

M64

Fabr.-No.

M63D

Fabr.-No.

M77

Fabr.-No.

Before operating any hoist, carefully read the entire manual. For hoists in trolleys, refer to the manual on **JDN Trolleys.**



CONTENTS

SAFETY INSTRUCTIONS

Organisational measures	5
Personnel safety	5
Preventing property damage	5

PRODUCT INFORMATION

The operation manual	6
Warnings and symbols	6
Identification	7
Operation possibilities	8
Explosion protection	8
Emission	8
Intended use	9
Conditions of use	9
Certification	9

APPLICATION

Application areas	10
Suspension points	10
Energy requirements	10

TRANSPORTATION AND STORAGE

Safe transportation	11
Storage conditions	11

SETTING UP

Initial operating checks	12
Testing the brake	12
Checking the direction of operation	12
Checking the overrun protection	12
Checking the emergency stop switch	12

OPERATION

Safety Instructions	13
Operating supplies	15
Controls	15
Chain	16
Emergency stop switch	17
Load hook	17
Starting operation	18
Troubleshooting	18

MAINTENANCE

Maintenance and inspection intervals	19
Care	19
Service	19
Inspections and maintenance work	21
Maintenance list	22
Inspection list	22
Test dimensions	23

ACCESSORIES

Chain container	24
Claw harness	25
Test dimensions for suspension chains	26
Service unit	27
Overload protection	30
Testing and adjusting the overload protection	30

ANNEX

Technical data	32
Dimensions	33



J.D. NEUHAUS

powered by air

Please note!

Within the Federal Republic of Germany

users of air hoists must comply with the currently applicable

- ▶ UVV Winches, Lifting and Pulling Devices (BGV D8), and
- ▶ UVV Loadcarrying Devices Used with Lifting Equipment (BGV D6),

and users of air hoists that are deployed in conjunction with trolleys must additionally comply with the currently applicable

- ▶ UVV Cranes (BGV D6).

Users must also initiate the prescribed tests.

In all other countries the user shall comply with local regulations as applicable.

Additional regulations may apply when incorporating air hoists into other installations or using air hoists in unusual conditions.



SAFETY INSTRUCTIONS

ORGANISATIONAL MEASURES

JDN Air Hoists are designed in accordance with the state of the art and accepted safety practice. Nonetheless, the use of an air hoist may be associated with the risk of injury or death of the user or of some third party, or with the risk of equipment damage.

All personnel charged with operating the air hoist must carefully read and understand the operation manual, especially the present section dealing with safety. This is particularly important when personnel not normally working with air hoists are charged with maintenance, repair or other additional works.

The user is under obligation to ensure that the air hoist is operated in a safe manner. The following measures are requested as a minimum:

- ▶ keep this manual readily available at the air hoist operating site,
- ▶ carry out training on air hoist operation on a regular basis,
- ▶ set up an inspection log and keep it up to date, and
- ▶ on a regular basis, check up on the personnel working with the air hoist to ensure that it is being used in a safe and proper manner.

PERSONNEL SAFETY

Ensure that only properly trained personnel are entrusted with the operation, maintenance, and repair of the air hoist.

“Properly trained” in the present case means that the operator has appropriate training and experience in working with air hoists and is sufficiently versed in occupational safety and accident prevention regulations to be able to determine whether or not it is safe to operate the air hoist.

- ▶ Follow the applicable regulations for the workplace in question.
- ▶ Observe all relevant accident prevention regulations, in particular BGV D8 (Winches, Lifting and Pulling Devices) and BGV D6 (Loadcarrying Devices Used with Lifting Equipment).
- ▶ Ensure that you are properly informed about any hazardous materials you may be working with.
- ▶ Follow the safety instructions given in this manual.

PREVENTING PROPERTY DAMAGE

The user of JDN Air Hoists is responsible for ensuring that the inspection log that is delivered with the hoist is correctly used and kept up to date.

- ▶ Ensure that the scheduled maintenance is performed as prescribed.
- ▶ Do not use the air hoist for any other purpose other than its intended design use.
- ▶ Ensure that the conditions of use as detailed below are met.



J.D. NEUHAUS

powered by air

PRODUCT INFORMATION

THE OPERATION MANUAL

The present manual is intended to help the operator to get familiar with JDN air hoists and how to use them properly.

This manual contains important information on the safe, proper, and economic operation of the JDN air hoists. By following this information the risk of safety hazards, repair costs, and machinery downtime can be reduced and the useful lifetime of the air hoist can be extended.

Always keep the manual readily available at the place where the JDN air hoist is being used.

All persons charged with operating, maintaining, or repairing JDN air hoists must read and follow the instructions in this manual.

WARNINGS AND SYMBOLS

In this manual warnings about safety are classified in three categories:



DANGER!

Indicates that failure to follow these instructions can cause a hazard to life and limb. The symbol indicates the immediate danger of severe and possibly fatal injuries.



WARNING!

Indicates a situation that could become hazardous. Failure to follow the instructions could result in injuries.



CAUTION!

Indicates that failure to follow the instructions could cause equipment damage.



IDENTIFICATION

The nameplate mounted on the hoist cover identifies the type of JDN air hoist and gives important rating information.

If you have any questions concerning the operation of the air hoist which are not addressed in this manual, please contact us at the following address:

J.D. NEUHAUS GMBH & CO. KG
 Windenstraße
 D - 58449 Witten-Heven

Phone +49 - 23 02 - 20 80
 Fax +49 - 23 02 - 20 82 86
<http://www.jdn.de>
 e-mail: info@jdn.de

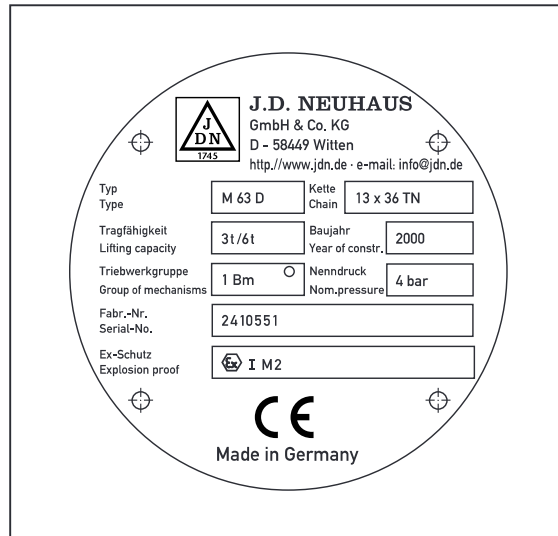

Example of a nameplate, mounted on the hoist cover



OPERATION POSSIBILITIES

JDN Air Hoists Types B24, B48, B612, M64, M63D and M77 are in accordance with the driving mechanism group 1 Bm/M3 (according to FEM/ISO). The sound pressure level at the measuring surface at 1 m distance from the machine surface was determined acc. to DIN 45635, Part 20 with an air pressure acc. to our instructions.

Hoists manufactured in series have a limited life time. After reaching this calculated time acc. to the corresponding driving mechanism group special tests have to be carried out (see the section entitled **Inspections and maintenance work**, page 21).

JDN Air Hoists which are used for tearing off stuck loads and/or for tensioning purposes during assembly works may only be operated acc. to the driving mechanism 1 Cm/M2. A general overhaul must be carried out once a year.

EXPLOSION PROTECTION

The following information base on the attestation of the DMT Company Gas & Fire Division with regard to the application of JDN hoists, trolleys and cranes in areas with danger of explosion following the European Guideline 94/9/EG1 ("ATEX 100a"). DMT is certified to test devices and protective Systems for its designed use in hazardous areas.

JDN air hoists, trolleys and also crane installations in **standard version** are generally applicable too in underground mines as well as in their bank-head installations which could be endangered by mine damp and/or by inflammable dusts. Within this utility group I they belong to category M2. These are devices which can be switched off in case of occurrence of hazardous atmosphere.

They are equipped with protective measures offering a high degree of safety. The protective measures of products of this category offer the necessary degree of safety under normal operating conditions even under severe working conditions and especially under rough treatment and changing ambient influences. For even harder conditions apart from the explosion protection

which prevail in underground mines when deploying these devices the special mining hoists of J.D. Neuhaus are available.

The maximum admissible surface temperature of 150° in damp atmosphere according to EN 13463-1* not reached.

For the application in mines the denomination of hoists, trolleys and cranes is:

⊕ I M2

MATERIALS WITH DANGER OF FRICTION AND IMPACTS

An increased danger of ignition arises when special material combinations run across one another as for example non corrosion-proof steel or cast iron against aluminium, magnesium or corresponding alloys especially in connection with rust or rust films. Especially at the friction points of chains and load hooks rust or rust films may occur. Therefore for the destined use of the hoists it has to be safeguarded that in the operating area of the hoists at possible friction impact or grinding points no material combinations of above mentioned light metals and steel (exception: stainless steel) are present so that sparking with these material combinations due to the mechanical influences can be excluded.

*EN 13463-1: Non-electrical devices for the application in hazardous areas - Part1: Basic methods and requirements

EMISSION

The sound emission figures are shown in table **Technical data**, page 32.

The sound pressure level at the measuring surface at 1 m distance from the machine surface was determined acc. to DIN 45635, Part 20 with an air pressure acc. to our instructions. The reduction of the sound level under indoor conditions is approx. 3 dB (A) per each doubled distance.

When in operation - due to motor lubrication - small amounts of lubricating oil are discharged with the exhaust air into the ambient atmosphere.

INTENDED USE

The JDN Air Hoists of the B and M series are designed for lifting loads with vertically arranged chain.

Under special safety precautions and considering the corresponding situation at site they can be used for horizontal pulling of loads or for oblique lifting or pulling.

Any other use shall be deemed improper. Such improper use is at the customer's own risk, and the company J.D. NEUHAUS GMBH & CO. KG shall not be liable for any resulting damages.

Please also see **Safety Instructions**, page 13.

CONDITIONS OF USE

The JDN Air Hoists are sturdy and require very little maintenance. They are suitable for use in locations subject to explosion hazards, as well as locations exposed to soot, dust, humidity and extreme temperatures between -20°C and approximately +70°C. Permitted chain and hook temperatures: -40°C up to +150°C.



WARNING!

When touching metallic hand controls being colder than 0°C frostbites of the skin may occur within a few seconds, at temperatures above +55°C burnings may occur. Protective measures: use suitable safety gloves.

CERTIFICATION

Every JDN Air Hoist is issued with a works certificate.



J.D. NEUHAUS

powered by air

APPLICATION

APPLICATION AREAS

Hoists intended for permanent outdoors operation must be protected against the influences of weather and the intervals between maintenance must be reduced.

SUSPENSION POINTS



DANGER!

Suspension points for JDN Air Hoists are to be constructed in such a way that the expected forces can be safely held. Ensure that your JDN Air Hoist can come free into alignment under load, otherwise unallowed additional forces can occur:



DANGER!

The supporting structure of air hoists must have a rigid bedding. Vibrations damage the chain and may lead to chain cracks. Furthermore no vibrations must be transmitted from the outside to the hoist (as for example by the suspended load).

ENERGY REQUIREMENTS

Air pressure, amounts and connections, see the section entitled **Technical data**, page 32.

DETAILS OF AIR PRESSURE

JDN Air Hoists are also identified by the nominal pressure (overpressure) stated on the hoist itself. With this value we want to assign the hoist to a corresponding pressure in the air line system.

When connected but not working the pressure of the air line system is on the hoist. After starting operation this pressure decreases to the actual working pressure which varies according to the load figure and the direction of the load movement (up or down). Furthermore it depends on the hose section, the hose length as well as on the diameter of the air line and its length.

When calculating the lifting capacity of the hoists we have therefore considered a loss of around 10% of the nominal air pressure for lifting the maximum load. In other words: A hoist with a nominal pressure of 4 bar reaches the stated parameters at a working pressure of 3,6 bar.

JDN Air Hoists must have sufficient supply of clean, dry working air (to fulfill this requirement an air dryer must be connected to the air supply if necessary).

Do not drive JDN Air Hoists with other gases (contact supplier).

The working air must meet the following quality standards:

Solid particle content:

- ▶ size of particles, smaller than 40 µm
- ▶ amount of particles, less than 5 mg/m³

Pressure dewpoint:

At least 10°C below the lowest expected ambient temperature at site.

For lubrication of the motor, the working air must contain lubricating oil in the following quantities:

Oil content:

- ▶ 25 mg per m³ air consumption
- ▶ If you do not use the built-in oiler in your JDN Air Hoist, you must ensure that the necessary amount of oil in the working air is provided by other measures (e.g. connection of a service unit with oiler). See the section entitled **Service unit**, page 26.

In areas where the surrounding temperature is 0°C or below and in case of longer periods of operation (e.g. several minutes) particular attention must be paid that the working air is not too damp. Danger of icing up of air hoses, control valves, motor and brakes!

Connecting an air dryer icing up can be avoided. Under certain conditions it is sufficient to feed the working air with lubricating oil with an anti-icing additive and/or to add pure alcohol to the normal lubricating oil. See the section entitled **Filling and adjusting the oiler**, page 19.



TRANSPORTATION AND STORAGE

SAFE TRANSPORTATION

**DANGER!**

Do not throw or drop your JDN Air Hoist. Make sure that load hook, chain loops and control hoses do not hang down. Control hoses and switches must not be damaged when handling JDN Air Hoists. Danger of incorrect functioning!

STORAGE CONDITIONS

Store your JDN Air Hoist in a clean and dry place.

Take care that control units and control hoses are not damaged.

Protect the air connection against damage or penetration of dirt or foreign particles.

In case of longer periods of idleness protect your JDN Air Hoist including chain and load hook against corrosion. To protect the motor against corrosion, pour conserving oil into the air supply hose after last use (see the section entitled **Operating supplies**, page 15), then run your JDN Air Hoist for a short period.

After longer periods of idleness clean the motor with about 30 cm³ of petroleum by pouring it into the air hose and then run your JDN Air Hoist for approximately half a minute. Then, straight away, pour a bit of lubricating oil into the air hose – further lubrication is carried out by the oiler.



J.D. NEUHAUS

powered by air

SETTING UP

INITIAL OPERATING CHECKS

Prior to initial use the hoist and supporting structure must be checked by a qualified person. Checking must also be carried out after any major modification. The object of such testing is to determine that the lifting equipment is correctly installed and ready for Operation.

TESTING THE BRAKE

The correct functioning of the brake must be tested before starting to use the hoist. Proceed as follows:

- ▶ Operate the hoist with no load, alternating between lifting and lowering.

The chain must stop running immediately after releasing a control button.



DANGER!

If you notice that the chain running does not stop immediately stop using the hoist at once! The hoist must be repaired before any further use.

CHECKING THE DIRECTION OF OPERATION

- ▶ Check that the load hook moves up and down in accordance with the markings on the hoist controls.

CHECKING THE OVERRUN PROTECTION

- ▶ Lift the load hook without load until it almost reaches the upper end.
- ▶ Carefully lift it still further, until the buffer drives against the housing.

The lifting process must be stopped by deformation of the buffer.



DANGER!

When the buffer is damaged, stop using the hoist immediately! Hoist must be repaired (exchange buffers).

CHECKING THE EMERGENCY STOP SWITCH

- ▶ Actuate lifting process and press down red emergency stop switch whilst lever is still pressed down. Lifting process must come to a halt immediately. Release emergency stop switch.
- ▶ Actuate lowering process and press down red emergency stop switch whilst lever is still pressed down. Lowering process must come to a halt immediately. Release emergency stop switch.



OPERATION

SAFETY INSTRUCTIONS

FOLLOW THESE RULES FOR SAFE HOIST OPERATION

JDN Air Hoists, series B and M are designed for a working pressure of 4 (four) bar.

The PS and DS Controls automatically limit higher circuit pressures up to 10 bar to the admissible working pressure.

With the E control, pressure reduction to 4 bar is necessary outside the hoist, e.g. by connecting a service unit with an adjustable pressure reducing valve.

Please note: Under special safety precautions and considering the corresponding situation at site air hoists of the B and M series can be used for horizontal pulling of loads or for manipulating loads obliquely in the area whereby no chain box is allowed to be used as the chain may fall out or form knots. Hoists mounted in trolleys are not allowed for oblique lifting. Please contact us in case of application.

Whenever you operate a hoist, you are responsible for your own safety and the safety of your fellow workers.

- ▶ Only persons duly authorised by the management shall operate the hoist.
- ▶ Before beginning to use the JDN Air Hoist you should inform yourself thoroughly about the correct method of operation. Read this manual carefully and carry out the indicated procedures on the hoist step by step.
- ▶ Report any malfunctioning to your safety representative at once, so that it can be corrected.
- ▶ Follow the instructions issued by the responsible accident prevention authorities (in Germany, these instructions are known as UVV's and are issued by the trade associations).

As a prerequisite for proper use the instructions in the operation manual must be observed and the recommended inspection and maintenance procedures must be carried out.

Hoists have to be checked by trained staff at least once a year or after a service time of 160 hours (see the sec-

tion entitled **Inspections and maintenance work**, page 21).

In addition to the annual inspection by an expert JDN Air Hoists should be checked according to the service and inspection lists (see the sections entitled **Maintenance list and Inspection list**, page 22).

For example JDN Air Hoists may not be used in the following areas:

- ▶ Critical surroundings in atomic plants.
- ▶ Above acid baths or similar plants with aggressive substances.
- ▶ In areas where organic acids can be found.

On the following pages some important points for the safe operation of your JDN Air Hoist are listed. They should help you to avoid hazards.

Improper use includes but is not limited to any and all of the following:

- ▶ Exceeding the rated load capacity.
- ▶ Trying to dislodge stuck loads.
- ▶ Load the hook at its tip.
- ▶ Catching a falling load.
- ▶ Using the hoist for transporting people.
- ▶ Hoisting by tipping the control buttons or levers over a longer hoisting distance.
- ▶ Reversing the hoist while it is in motion.

For the safety of all personnel it is vital to follow the instructions given below whenever operating a JDN Air Hoist:

- ▶ Never touch a running chain.
- ▶ Never allow any person to stay under a raised/suspended load.
- ▶ When hooking loads observe appropriate regulations.
- ▶ Make sure that the operating place is without any danger for the operator due to suspension or load.
- ▶ Start carefully when lifting or pulling loads.
- ▶ Never try to correct a fault or damage while the hoist is under load.
- ▶ Never run to end positions under normal working conditions.
- ▶ Never use bent, open or twisted hooks.
Hoist to repair, never straighten, change hook.



J.D. NEUHAUS

powered by air

- ▶ Never use stiff moving hook. Inspection.
- ▶ Never load hook on the tip, only on deepest part of hook saddle.
- ▶ Never lock hook at connecting point.
- ▶ Never anneal the hook.
- ▶ Never block operating elements.
- ▶ Never use stiff operating elements. Repair shop.
- ▶ Operate JDN Air Hoists only with original JDN controls.
- ▶ Uncontrollable external power influences (e.g. through hydrocylinder, falling loads) are not permitted.
- ▶ Use only suitable and approved harness, do not jam hook at the fixing point of the harness.
- ▶ Never use the hoist chain for wrapping around a load to be lifted.
- ▶ Position the load vertically under the hoist before lifting. The chain should be hanging straight down.
- ▶ Never allow a load to drop into the harness.
- ▶ Before lifting or pulling a load, ensure that it does not exceed the rated capacity of the hoist including the weight of the load and the harness.
- ▶ Do not take up the load at full speed if the chain is initially slack.
- ▶ Ensure that the load is in a stable position when lifting, pulling or lowering it down to avoid accidents caused by a toppling or falling load.
- ▶ Never use the hoist in an attempt to dislodge a load that has become stuck.
- ▶ Never lift or pull more than one load at a time.
- ▶ Never allow the chain to be bent.
- ▶ Save the load in case of loss of energy.
- ▶ Do not join or mend hoist chain.
- ▶ Exchange deformed load hook.
- ▶ Repair damaged hook safety latch.
- ▶ Do not bend or squeeze control hoses.
- ▶ Loose screws must be fastened by repair shop.
- ▶ Shut off air supply before taking off air hoses.
- ▶ Do not exceed allowed quantity of chain in the chain container (if existing).
- ▶ When working without chain container avoid dangers caused by the idle chain: falling down, interlocking, striking (see section **Chain Container**, page 24).
- ▶ Repair hoist in case of a too long braking distance.
- ▶ Check blocked chain for damages.
- ▶ Check chain for damage if hoist blocks in switched on position.
- ▶ In case of lifting a load with several hoists avoid overloading by wrong load distribution. Avoid unacceptable load distribution.
- ▶ Choose safe place of control.
- ▶ Do not exceed the operating pressure.
- ▶ Put in order twisted chain (capsized bottom block).
- ▶ Do not work with damaged or worn or rusty chain.
- ▶ Do not work with chain pulled rigid, bent or extended chain.
- ▶ Do not use the load chain as a sling for suspension.
- ▶ It is not permitted to connect or repair hoist chains (e.g. with bolts, emergency links or otherwise).
- ▶ Remove chain accumulated in front of chain intake.
- ▶ Do not bend the chain.
- ▶ Admissible temperature range for chain and hook: -40°C up to +150°C, permitted heat bearing capacity of the body of the air hoist max. 90°C, permitted ambient temperature: -20°C up to +70°C.
- ▶ Never touch metallic hand controls being colder than 0°C or warmer than 55°C without using suitable safety gloves.
- ▶ Do not carry out any modifications on the air hoist.
- ▶ It is not allowed to use other than JDN components with JDN Air Hoists because of the dangers connected therewith.
- ▶ Only use original JDN spare parts. When using foreign components and/or carrying out changes by non authorised persons J.D. Neuhaus GmbH & Co. KG does not undertake any responsibility.
- ▶ If the air supply is cut protect area around the load until power is restored.
- ▶ Turn off the compressed air before detaching the air hoist from the compressed air system.
- ▶ When lifting: Do not start a double or multiple fall chain hoist when the bottom block is still supported.



DANGER!

Make sure that the load hook can be lowered up to the floor at all operating conditions of the air hoist in order to avoid that a load is lowered to its lowest position without reaching the floor. Danger of overloading.

In case of using hoists in extremely difficult conditions the user has to work out a directive on the basis of this Operation Manual understandable for and in the language of the operator. In this directive regulations for the safe operation are stipulated considering the special conditions at site.

In addition, it is essential to follow all instructions given in the sections entitled **Intended use and Conditions of use**, page 9.

JDN Air Hoists are equipped with round steel chains as load chains. When in use section 5 of DIN 685 should be observed.

Extract: "At the instigation of the operator chains in use should be checked and tested at regular intervals by a responsible expert" (see the section entitled **Inspection list**, page 22).

OPERATING SUPPLIES

For lubrication of motor:

- ▶ Lubricating oil (pneumatic oil) kinematic viscosity approx. 30 mm²/s (cST) at 40°C, DIN 51502.
- ▶ Additives: Anticorrosive, wear protection and cleaning.
- ▶ Having ambient temperatures of 0°C or below and according to the humidity of the compressed air an anti-freeze additive to the lubricating oil or pneumatic oil with anti-freeze additive for the appropriate temperatures is recommended.

FOR MOTOR PRESERVATION

- ▶ A non gumming and non-sticking protecting oil which has a protecting time corresponding to the intended period of idleness.

FOR MOTOR CLEANING

- ▶ Pure petroleum.

FOR CHAIN LUBRICATION

- ▶ Motor oil, kinematic viscosity approx. 150 mm²/s (cST) at 40°C.

For lubricating bearings and gears: roller bearing grease, lithium saponified, felting penetration 265 - 295 (0,1 mm), dripping point: 190°C, temperature range of application: -30°C up to +130°C, ground oil viscosity at 40°C: 190 mm²/s, acc. to DIN 51502 additives: protection against corrosion and ageing.

In application areas where aggressive surrounding influences affect wear, please contact the manufacturer.

CONTROLS

JDN Air Hoists are operated by:

- ▶ Push button controls (E or PS controls) or by:
- ▶ lever control (DS control).

The operating elements (push buttons, levers) return automatically to zero position when released.

In order to avoid incorrect operation of the E or PS controls, always press only one of either buttons.

With the DS control move the lever either to the left or to the right.

When operating the JDN Air Hoists with two hooks please pay attention to the special denomination of the control elements regarding the co-ordination of the hook movement.

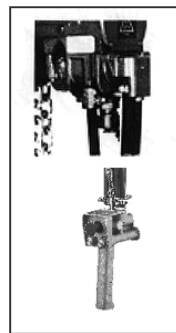
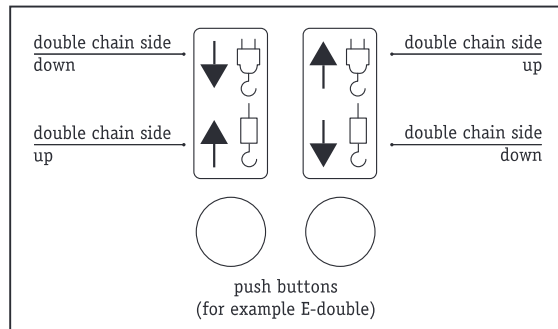

E-Control

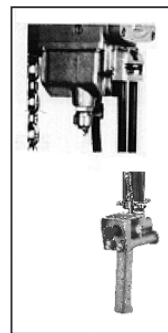

PS-Control

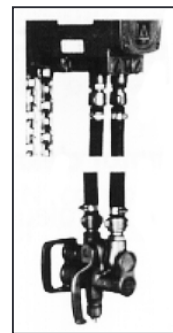

DS-Control



J.D.NEUHAUS

powered by air

CHAIN

RULES FOR RUNNING IN HOIST CHAINS BEFORE CARRYING OUT THE OVERLOAD TEST



CAUTION!

In case this information should not be observed you damage the high tensile chain in your hoist/lifting gear already during testing prior to initial use for which the manufacturer does not undertake any liability.

Hoisting chains have to be run in before carrying out the overload test so that they can withstand the high surface pressure at the contact points of the chain links (in the joints).

For preparing the test with overload the following prerequisites have to be fulfilled:

1. The chain has to be carefully lubricated in the joints. Please observe the relevant information in the Operation Manual.
2. The chain has to be loaded five times by lifting and lowering with approximately 50% the nominal load thus sufficiently increasing the load bearing capacity of the joints.
3. Especially the part of the chain which will be tested with overload has to be carefully lubricated once again. Only now the overload test can be carried out.



DANGER!

Extreme corrosions (pitting corrosion) heavily reduces the resistance against vibrations of chains. **Danger of cracks!** Hydrogen induced brittleness with following stress corrosion cracking due to corroding media (as for example sea water) can occur at high tensile steels (as for example at the chain).

Danger of cracks!

So-called recombination poisons as for example hydrogen sulphide, cyanides, arsenic compounds and rhodanides favour this procedure. Furthermore dangers arise due to rusty chains when using chain containers as the chain may fall out of the box when piling up.

Before operation ensure that the chain of your JDN Air Hoist is in perfect condition.



CAUTION!

Order any twisted chain.

Ensure that the chain can run straight so that blocking of the chain intake at the mid section is avoided. The chain has to be checked in regular intervals (see the section entitled **Inspection list**, page 22).

By any of the following defects (hoist chain and/or suspension chain):

- ▶ elongated chain links
- ▶ bent chain links
- ▶ externally damaged links
- ▶ chain drawn stiff
- ▶ severe wear in the link joints
- ▶ corrosion scars

the JDN Air Hoist must be sent for overhaul immediately (see the section entitled **Test dimensions (hoist chain and hook)**, page 23).

The chain must be lubricated when not under load (see the section entitled **Lubrication of the chain**, page 20). Suitable lubricant: see the section entitled **Operating supplies**, page 15. The lubrication intervals depend on the daily running time.

Increased wear may occur due to aggressive environmental influences

- ▶ shorten maintenance intervals.

For safety reasons please note that the chain may not be

- ▶ used as a sling round the load for suspension
- ▶ gripped while running
- ▶ run at an angle so that the links can be bent on entry
- ▶ repaired or attached to other hoist chains (e.g. with screws, emergency links or otherwise).

The admissible chain temperature ranges from -40°C to $+150^{\circ}\text{C}$.

If you use a chain box, the permitted filling capacity may not be exceeded (see the section entitled **Chain container**, page 24).

EMERGENCY STOP SWITCH

In the EU each control is equipped with an emergency stop switch as standard. Outside the EU the control will be equipped with an emergency stop switch on special request only.

In order to quickly avert a hazard caused by the hoisting movement the push buttons have to be released interrupting the hoisting movement immediately.

Only in case this stop function fails the red emergency stop switch has to be firmly pressed down thus closing the motor valve and halting the motion of the load hook. The emergency stop switch engages. The push buttons for lifting and lowering are out of function. The emergency stop switch can be unlatched by pulling out. It goes back into zero position.

**DANGER!**

Never unlatch the emergency stop switch before the hazard has been removed and the stop function of the push buttons has been re-established.

LOAD HOOK

When operating the JDN Air Hoist with two load hooks it is forbidden to use both load hooks at the same time.

Should such an operation with two hooks not be allowed for reasons of internal or national regulations one of the two hooks has to be removed – in the case of JDN Air Hoists with single or double falls it should be the one with the smaller carrying capacity.

Check the hook opening “a” and the height “h” of the load hooks of the JDN Air Hoists in use at least once a year (see the section entitled **Test dimensions (hoist chain and hook)**, page 23). The hook opening “a” can be checked with the JDN load hook gauge.

In addition, check the load hook fastening regularly for unusual wear.

**DANGER!**

Load hooks may not be

- ▶ Loaded on the point
- ▶ Bent back into shape
- ▶ Annealed

If the hook is bent the JDN Air Hoist must be sent for inspection.

The admissible load hook temperature ranges from -40°C to $+150^{\circ}\text{C}$.

LOAD HOOK AND LOAD HOOK SEAT

In case the play between hook shank and profile of the casting (bottom block or load sleeve or suspension sleeve) is more than 5 mm – even on one side only – the damaged parts have to be exchanged.

Bent apart halves of the load hook seat must be exchanged if the gap between the bearing surfaces is more than 0,5 mm.

Likewise those parts have to be exchanged which show outside damages due to forced influences (like broken off or broken out parts).



J.D. NEUHAUS

powered by air

STARTING OPERATION

JDN Air Hoists are to be checked by trained staff before being put into operation. When using the PS or E control the lubricator must be filled with oil before initial use (see the section entitled **Service**, page 19).

Lubrication of the chain before initial use is especially important (see the section entitled **Lubrication of the chain**, page 20).

A correct running of the chain is essential for the proper operation of the JDN Air Hoist. Before every operation, please check that the chain is not twisted or the bottom block – if applicable – is not distorted with the two falls. Order the chain if necessary.

Pay attention to all relevant regulations when attaching loads!

Before every operation, action should be taken in the following order:

1. Check power requirements (air pressure and air consumption see the section entitled **Technical data**, page 32).

2. Check the oil level in the oiler and if necessary refill (see the section entitled **Filling and adjusting the oiler**, page 19).
3. Lubricate the chain.
4. Blow through the air hose before connecting.
5. Connect air supply hose (for size of hose and air connection screw see the section entitled **Technical data**, page 32). Check that connection nipple and cap nut are clean.
6. Test the brake function and – at the same time – the control and the buffers of the overrun protection. Switch the JDN Air Hoists for short periods alternately to lifting and lowering. When the control unit (push button or lever) is released the chain should not continue to run. If the chain continues to run and/or the control elements do not automatically return to the zero position, your JDN Air Hoists must be sent for repair!

TROUBLESHOOTING

problem	suggested remedy
motor has insufficient capacity or stops	<ul style="list-style-type: none"> - check air pressure, increase if necessary (see the section entitled Energy requirements, page 10) - check diameter of air hose (see the section entitled Technical data, page 31) - check hose for free passage of air - check oil level - check control hoses and control hose connections for permeability

MAINTENANCE

In addition see the section entitled **Maintenance list**, page 22.

MAINTENANCE AND INSPECTION INTERVALS

The JDN Air Hoists are sturdy and require little maintenance. To ensure that the hoist continues to provide reliable service for a long time, it is very important that the recommended intervals for the inspections and maintenance required be observed. If the hoist is being operated in a harsh environment that leads to accelerated wear, then the intervals should be reduced.



WARNING!

Only properly trained technicians should be allowed to perform maintenance work on JDN Air Hoists.

Qualification of the maintenance staff see the section entitled **Safety instructions**, page 13.

CARE

If your JDN Air Hoist is not suspended, mounted or built in a permanent position, but constantly changing operating location – especially in contaminated or humid surroundings – ensure that for periods of idleness it is stored in a clean and dry place.

SERVICE

FILLING AND ADJUSTING THE OILER

The motor of your JDN Air Hoists is lubricated by the oiler contained in the attached housing or control valve. The contents of the oiler is sufficient for eight hours of operation.

Check the oil level before every operation and refill – if necessary – (see below)!

Should, as an exception, your JDN Air Hoist be operated with an empty oiler, approximately 5 cm³ of oil per working hour must be poured into the air hose.

FILLING THE OILER

- ▶ Disconnect the JDN Air Hoist from the air line.
- ▶ Unscrew the oil filling plug (A), carefully allowing the remaining pressure to escape.
- ▶ Fill up with pneumatic oil until it overflows.
- ▶ Replace the oil filling plug.

ADJUSTING THE OILER

Only oilers of JDN Air Hoists with E or PS controls are adjustable!

- ▶ Disconnect the JDN Air Hoists from the air line.
- ▶ Unscrew locking screw B.
The adjusting screw C can now be seen.
- ▶ Turn the adjusting screw to the right as far as possible.
- ▶ Now untie the adjusting screw by half a turn the left.
- ▶ Replace the locking screw.

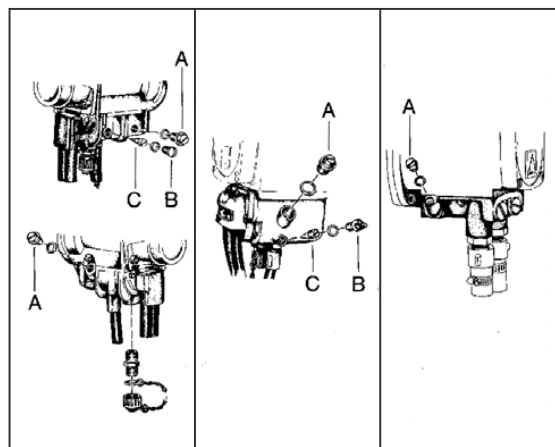

E-Control

PS-Control

DS-Control

When nozzle is blocked:

Unscrew adjusting screw C and clean the jet boring with a thin wire.



J.D.NEUHAUS

powered by air

TESTING THE CONTROL UNITS

The switching elements of your JDN Air Hoist should return automatically to the zero position when released.

Check daily the switching elements for free moving.



DANGER!

If any switching element is hard to operate or sticks in the down position, stop using the hoist immediately. The control must first be repaired.

TESTING THE OVERRUN PROTECTION

- ▶ Check by sight daily whether buffer is damaged.
- ▶ If considerable damages at the buffer are found or when it is completely damaged, a 20 cm long piece of the chain has to be cut of just above the load hook to prevent cracks.
- ▶ Exchange buffer during annual inspection, check buffer disk for damages, exchange if necessary.



DANGER!

If the buffer is damaged stop using the hoist immediately! Send it for repair (exchange buffer).

INSTRUCTIONS FOR E AND PS CONTROLS

When there is no pressure on the push buttons they should return to zero position by their own weight.

TESTING THE BRAKE

Before putting your JDN Air Hoist into operation test the brake function.

- ▶ Operate the hoist with no load, alternating between lifting and lowering. When the switching element is released, the chain may not continue to run.



DANGER!

If you notice that the chain does not stop running immediately, stop using the hoist at once! The hoist must be repaired before any further use.

Due to physical reasons the stopping distance cannot reach the value zero but during this function test it must not be visibly noticed the chain slows down.



DANGER!

When operating the hoist be careful that the hook does not run to the end position.

CLEANING THE FILTER AT AIR INTAKE

Clean the filter (S) at air intake of your JDN Air Hoist daily.

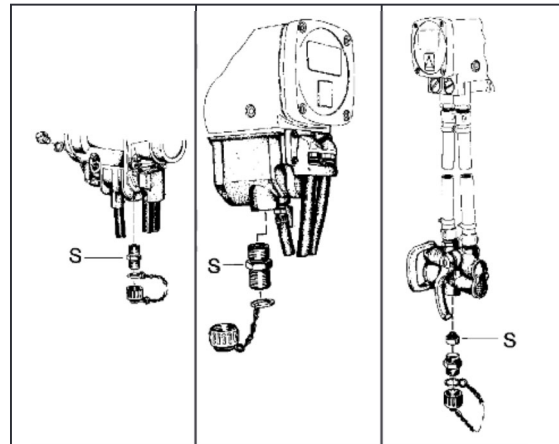

E-Control

PS-Control

DS-Control

LUBRICATION OF THE CHAIN

The joints of the chain of your JDN Air Hoist must be lubricated without load.

- ▶ Place the chain in an suitable container.
- ▶ Spray the chain with an automotive motor oil until it is completely covered with an oil layer. See the section entitled **Operating supplies**, page 15.
- ▶ If there is no container available for carrying out lubrication the chain can be lubricated while it is hanging. Ensure that the links are completely coated with oil (e.g. by moving).

You can get from JDN a high duty lubricator in a sprayer which sticks well to the chain and does not drop after the solvent has evaporated, article No. 12066 (sprayer 400 ml).



INSPECTIONS AND MAINTENANCE WORK

In addition see also the section entitled **Inspection list**, page 22.

Hoists manufactured in series are classified into groups and dimensioned acc. to their planned operating method (driving mechanisms acc. to FEM/ISO). The daily operating time and the loads to be handled determine the classification (1Bm/M3). The theoretical service time is 1600 hours in the load collective 2 (middle), corresponding to 400 hours of full load. Whereby it is supposed that the distance for lifting and lowering is more or less the same.

The theoretical service time of hoists used mainly for lowering purposes (approx 75 % of the duty cycle) would be reduced because of the higher lowering speed in the range of 50 % to 100 % of the nominal load. The factor f_v has the value 1 at 50 % nominal load linearly ascending to 1,5 at 100 % nominal load (P = percentage of nominal load).

For devices mainly used for lowering purposes (as from 75 % duty cycle) the theoretical service time would be reduced by around 50 % to 100 % nominal load due to the higher lowering speed. Therefore the calculated used portion of the theoretical service time must be multiplied with the factor f_v .

$$f_v = 1 + 0,5 \frac{P-50}{50} \quad (\text{for } P > 50\%)$$

In order to obtain safe working periods the user has to check at each inspection whether the theoretical service time has been reached. This has to be documented at least once a year in the check book which contains an example how the actual service has to be calculated.

When the theoretical service time is reached a general overhaul has to be carried out which has to be initiated by the user and to be documented in the check book. For information on the general overhaul consult the manufacturer. Only when the assumption for the group classification is in accordance with the practical operation of the hoist a safe working period corresponds to the theoretical service time. Any deviation between the actual working time and the theoretical service time increases or decreases the safe working period (see the section entitled **Operation possibilities**, page 15).

Detailed information on calculating the actual service time and its documentation have to be derived from the local safety regulations.



J.D. NEUHAUS

powered by air

MAINTENANCE LIST

No.	Maintenance procedure	Interval	see the section entitled
1	Check oil level for motor lubrication	daily	Filling and adjusting the oiler , page 19
2	Check emergency stop switch	daily	Checking the emergency stop switch , page 12
3	Clean filter at air intake	daily	Cleaning the filter at air intake , page 20
4	Lubricate the chain	as required	Operating supplies , page 15 and Lubrication of the chain , page 20

Note: All these measures are described in the section entitled **Service**, page 19

INSPECTION LIST

The stated intervals refer to normal operation (see the section entitled **Operation possibilities**, page 8). In case of more severe working conditions these intervals have to be shortened accordingly.

No.	Inspection procedure	Interval
1	Inspect the chain	every three months at least
2	Inspect sprocket wheel and chain guide	every time the chain is changed
3	Check brake wear	every 250 hours
4	Check all screw and bolt connections	every 250 hours
5	Check seating and condition of load hook and eye (load and suspension side)	every 250 hours
6	Inspect the motor	every 250 hours
7	Check gears and change lubrication	every 250 hours
8	Check coupling	annually
9	Check load coupling	annually
10	Check wear on controls	annually
11	Check load limiter ¹	annually
12	Check service unit ¹	annually
13	Check filter silencer ¹	annually
14	Check suspension chain ¹	annually
15	Check switching elements see the section entitled Testing the control unit , page 20	daily
16	Check brake function see the section entitled Testing the brake , page 20	daily
17	Check buffers of the overrun protection	daily
18	Check air connections for damage	yearly
19	Change buffers of the overrun protection	yearly

¹ if existing

**TEST DIMENSIONS
(HOIST CHAIN AND HOOK)**

chain d x t	9 x 27	13 x 36	16 x 45	22 x 66
A max.	320.5	429.2	536	783.4
11 · t inside	303.2	404.3	505.3	741.2
B max.	28.4	37.9	47.4	69.5
C min.	8.1	11.7	14.4	19.8
D max.	46.4	63.9	79.3	113.3

Dimensions in mm

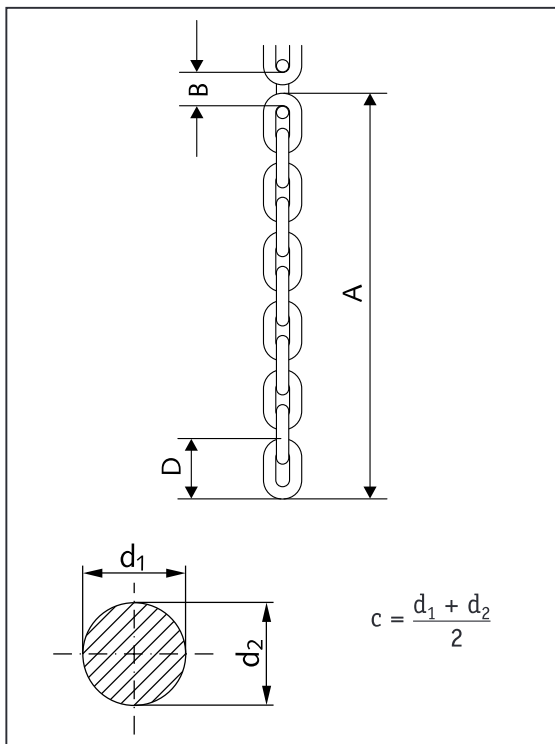

Note: When checking the extent of wear, the wear which will occur in the period until the next check must be taken into consideration.
The sprocked wheel should be exchanged at the same time when exchanging the chain, as otherwise the new chain will be subject to increased wear.
Each chain change has to be documented in the check book.

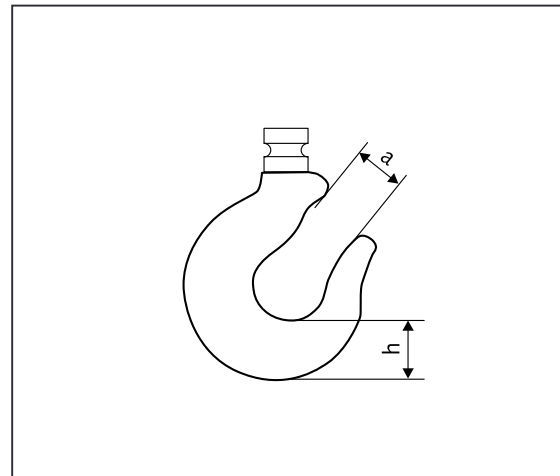

Load capacity	Maximum hook opening "a"	Minimum height "h"
up to 2t	36.5 mm	28.5 mm
3t	35.7 mm	36.1 mm
4t	35.7 mm	36.1 mm
6t	46.0 mm	41.3 mm
8t	46.0 mm	44.7 mm
10t	50.4 mm	58.9 mm
12t	50.4 mm	58.9 mm



J.D. NEUHAUS

powered by air

ACCESSORIES

CHAIN CONTAINER

Use only JDN chain containers with JDN Air Hoists. Other constructions could be a high safety risk.

Never exceed the permitted filling capacity for a chain container.

For chains in containers lubrication is of utmost importance for making full use of the bucket capacity. Rust on chains assist high piling up of the chain in the bucket and is therefore not allowed.

When the chain runs into the container it has to be observed that between lower edge of mid section and chain pile at least 5 chain links can hang without obstruction.

The chain may only pass into the container over the chain drive. Should it have fallen out of the container for example during transportation it must be completely extended at the load hook side and then returned into the container over the chain drive with running hoist.

In case a load is fastened directly under the load hook it has to be safeguarded that it cannot be driven against the chain container. If necessary a clamping sleeve has to be mounted on the chain above the load hook acting as an emergency stop at the control lever.



DANGER!

When operating JDN Air Hoists without a chain container it has to be made certain that the idle chain running up and down the chain sprocket (unloaded chain end) does not cause any risks for example by interlocking, striking or falling down.

Crash dangers may also arise when during the lifting process the idle chain at first settles on large surface loads or other surfaces above the transport level and then slides or falls down.



DANGER!

Do not exceed the admissible filling capacity! Danger of a chain drop!



DANGER!

When using a chain container the lubrication of the chain is of special importance to avoid the chain to fall out.



CAUTION!

The chain container must be protected against impacts from the load when lifting. Fit a chain stop to the chain if required.



CAUTION!

Do not allow the chain to pile up in the chain container.



CLAW HARNESS

JDN Air Hoists can be fitted with a claw harness instead of the load hook. Only use original JDN claw harness – the use of other products could mean big safety risks.

Ensure that the contracting claw is in the correct position. Only the released or loose chain can be placed in the contracting claws.

The expansion width of the chain loops may not exceed 100°.

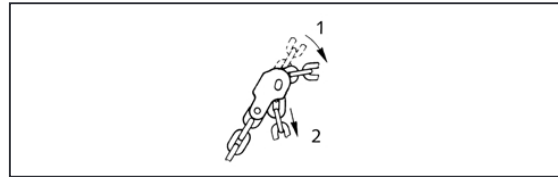
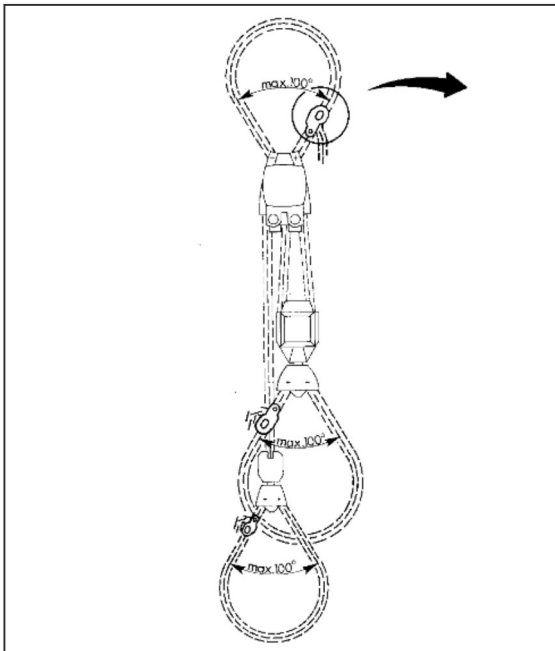

Unhooking of the chain loops

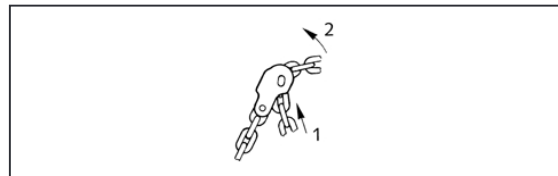

Hooking of the chain loops



J.D. NEUHAUS

powered by air

**TEST DIMENSIONS
FOR SUSPENSION CHAINS**

The suspension chains (carrying harness and claw harness) have to be regularly checked for good order. Test criteria are elongation due to plastic deformation and wear in the joints. When reaching the values in the table below the chain has to be exchanged.

Chain d x t	9 x 27	10 x 30	13 x 39	16 x 48	18 x 54	22 x 66
C min.	7.7	8.5	11.1	13.6	15.3	18.7
D max.	45.8	50.8	66.1	81.1	91.2	111.5
t max.	29.1	32.4	42.1	51.8	58.3	71.3

Dimensions in mm

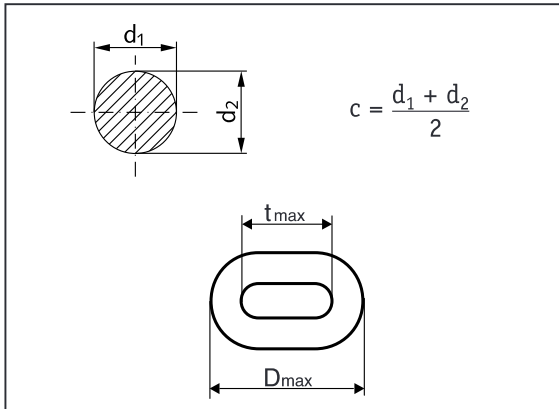

SERVICE UNIT

The service unit consists of the two components filter-regulator and lubricator.

INSPECTING AND ADJUSTING THE FILTER-REGULATOR

The filter-regulator is set in the factory at an operating pressure of 3,6 bar (operating pressure with running motor) whereby the manometer can show more than 4 bar with switched off motor. A faultless adjustment is only reached at a pressure upstream of the service unit of at least 5 bar.

- ▶ Lift the adjusting knob.
- ▶ Turn the regulator knob until the pressure gauge shows 3,6 bar.
Turn clockwise to increase the pressure or counter-clockwise to decrease it.
- ▶ Latch the adjusting knob by pressing it down.

Alternatively, you can set the filter regulator to 4 bar with halted motor which will require a pressure of at least 5 bar upstream the service unit.

- ▶ Relieve all pressure from the air line behind the service unit and close it again.
- ▶ Turn the adjusting knob counter-clockwise to detension the adjusting spring.
- ▶ Turn the adjusting knob until the pressure gauge shows a pressure of 4 bar. Turn clockwise to increase the pressure, or counter-clockwise to decrease it.
- ▶ Latch the adjusting knob by pressing it down.

If the operating pressure does not reach 3,6 bar despite a sufficiently high pressure upstream the service unit, then the cross section of the air feeding hose is too small!



filter-regulator and lubricator

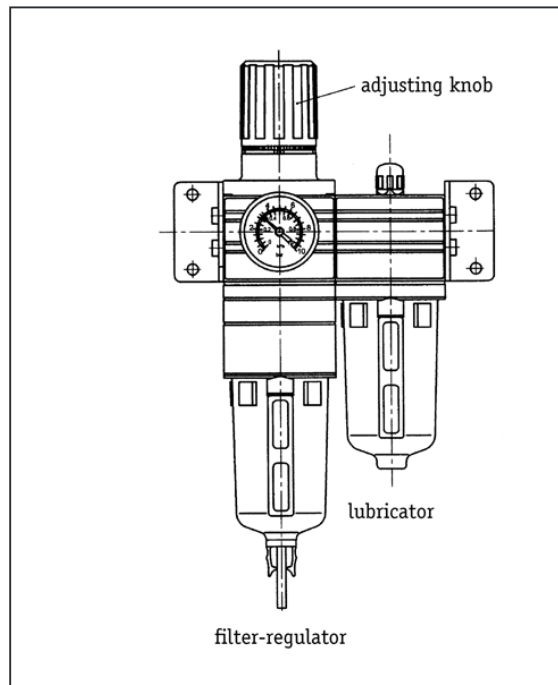

DRAINING THE MOISTURE

In the course of time moisture is gathered in the receptacle of the filter-regulator which has to be drained in regular intervals. Please proceed as follows:

- ▶ Check the water level visible through the sight glass in the receptacle. The water level may not reach the separating disc.
- ▶ Mount the enclosed drain hose (instead of this a soft PVC-hose of a diameter of 8 x 1 of corresponding length may be used).
- ▶ Collect the drained water and dispose it in a suitable manner as it may contain oil.

CLEANING THE FILTER ELEMENT



CAUTION!

Do not use any alcohols for cleaning the service unit! Alcohol may damage parts of the service unit. Transparent parts may only be cleaned with soap.

The filter element must be cleaned once per year as follows:

- ▶ Drain the water.
- ▶ Shut off the compressed air supply, carefully relieve any remaining pressure.
- ▶ Unlock the receptacle of the filter-regulator, turn it to the left until it stops and remove it.
- ▶ Unscrew the separating disc. The filter element is loosely positioned on the centre of the separating disc.
- ▶ Clean the filter element with soap water and blow through it firmly.
- ▶ Remount the clean filter element and tighten the separating screw.
- ▶ Put receptacle of the filter regulator back into the housing and turn it to the right. The receptacle locks by itself.

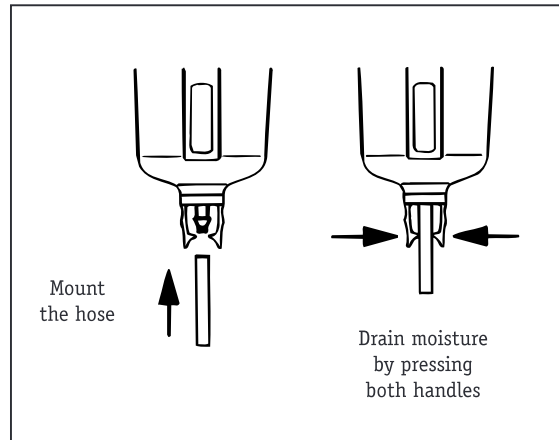

Draining the moisture

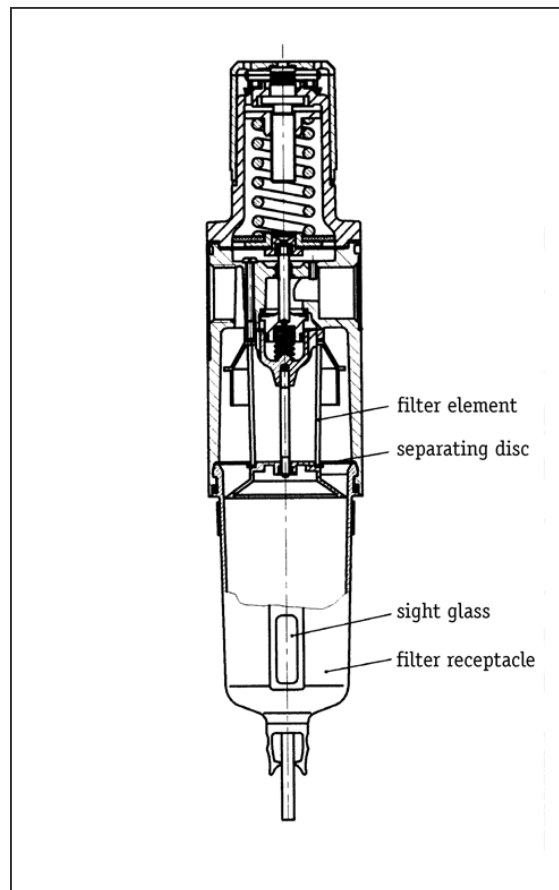

Cleaning the filter element

FILLING AND ADJUSTING THE LUBRICATOR

The function of the lubricator is to ensure that the air supplied to the hoist receives a constant and precisely metered quantity of oil. It is very important to check the lubricator regularly as the vane motor could be damaged in case of insufficient lubrication. The lubricator can be filled even when it is under pressure.

- ▶ Check the oil level through the sight glass of the receptacle. The oil level may not fall short of the minimum marking!
- ▶ Unscrew the oil filling plug.
- ▶ Fill the lubricator with oil up to the maximum marking and replace the oil filling plug.
- ▶ Check the oil dripping rate through the sight glass with running motor.
- ▶ Turn the oil throttle screw with a screw driver until reaching the required number of oil drops per minute. Turn clockwise to reduce the dripping rate, counter-clockwise to increase it.

Oil dripping rates:

For M64, B24:

6 drops per minute

For M63D, B48, B612:

10 drops per minute

For M77:

15 drops per minute

Adjustment while lifting without load.



CAUTION!

It is not allowed to fill the lubricator with synthetic oils. It may neither be connected to an air system fed by a compressor which is lubricated with synthetic oils.

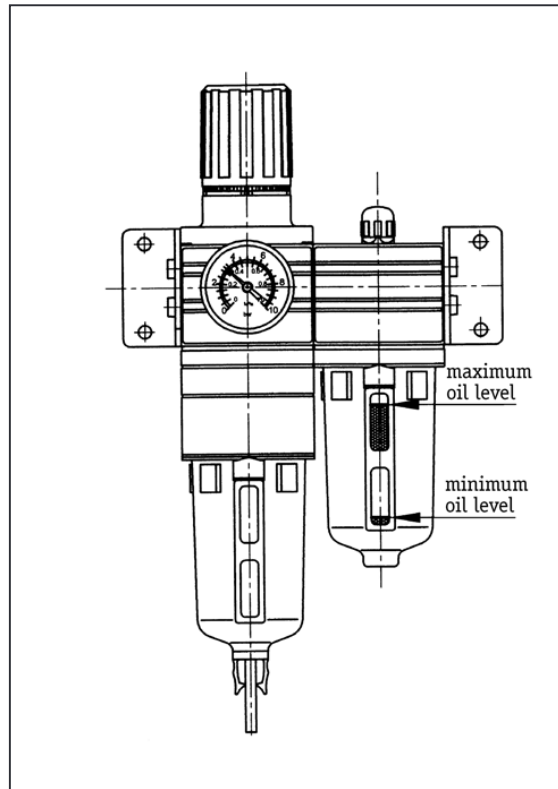

Check the oil level and refill if necessary

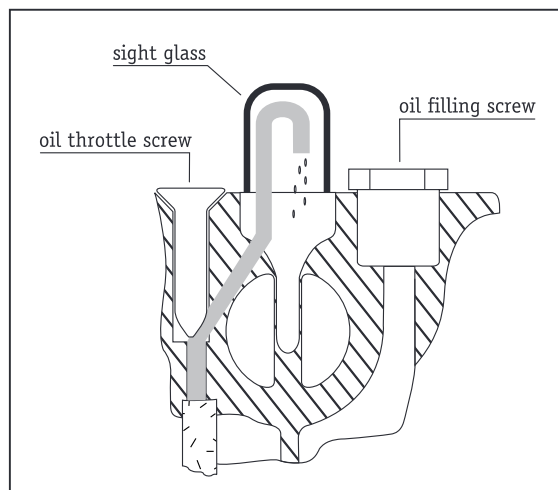

Checking and adjusting the oil dripping rate through sight glass



J.D. NEUHAUS

powered by air

OVERLOAD PROTECTION

The JDN air hoists M63D, B48 and B612 (versions equipped with one load hook) can be equipped with an overload protection. The overload protection automatically stops the lifting operation if the load reaches or is greater than the maximum setting. The shutoff setting is between 110% and 125% of the hoist's rated maximum load capacity.

If the overload protection has been actuated, only the "Down" motion can be initiated. As soon as the load drops below the shutoff setting, the overload protection is released, and the lifting operation can be started once again.

The overload protection may also be actuated by a load that weighs less than the shutoff setting. This may happen if the hoist is traversed upwards at full speed with a slack chain, and run against the resistance of the load to be lifted. For this reason, we recommend to tighten the slack of the chain slowly, before commencing normal lifting operation.

If you wish to add the overload protection feature to your M63D or B48 hoist, consult the customer service department of J.D. NEUHAUS GMBH & CO. KG

TESTING AND ADJUSTING THE OVERLOAD PROTECTION

PRINCIPLE OF OPERATION OF THE OVERLOAD PROTECTION

The overload protection reacts to the pressure differential inside the air motor between the compressed air inlet and the air exhaust. This difference is a function of the air pressure and the size of the load being hoisted. A pressure balance piston measures this difference, and if it reaches the shutoff setting, sends a signal impulse to the 3/2 valve.

This 3/2 valve normally allows the "UP" brake opening air to pass through, as long as the load is within the permissible range.

If there is a signal impulse from the pressure balance piston the 3/2 valve switches over interrupting the sup-

ply of brake opening air and venting the brake at the same time.

Once the overload protection has been set, it is impossible to lift the load, as the 3/2 valve remains in its position until DOWN button or lever has been activated.

OVERLOAD TESTING WITH M 63 D

When checking the hoist with overload without causing the hoist to shut-off, the locking screw (see figure) has to be removed.



DANGER!

After the check the locking screw has to be reset.

ADJUSTING THE OVERLOAD PROTECTION



DANGER!

If the overload protection is incorrectly adjusted, the chain may break.

- ▶ Loosen the retaining screw in order to reach the threaded lug underneath it.
- ▶ Turn the threaded lug to adjust the overload protection setting. Turn the lug clockwise to increase the shutoff setting, or counterclockwise to decrease the setting.
- ▶ Replace the retaining screw and tighten it down before setting the overload protection for correct functioning.

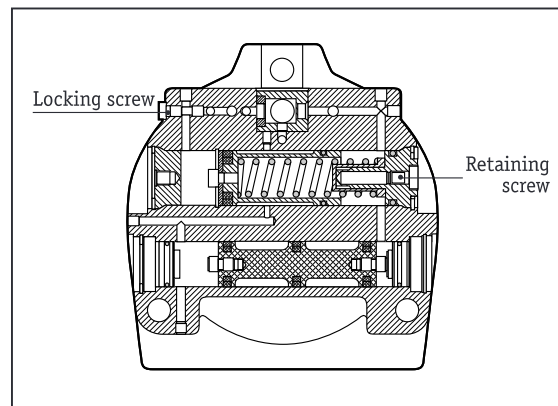

Overload protection

OVERLOAD TESTING WITH B 48 AND B 612

For the purpose of overload testing, it is possible to override the function of the overload protection.

**DANGER!**

After completing the overload test, always tighten the plug screw until it seats firmly.

- ▶ Loosen the cover screw (1) at the housing
- ▶ Loosen the plug screw.

Now the pressure balance piston is not activated at the "UP" side, and the overload protection is out of function.

- ▶ After completing the overload protection test, tighten the plug screw until it seats firmly.
- ▶ Replace the cover screw (1) at the housing.

ADJUSTING THE OVERLOAD PROTECTION**DANGER!**

If the overload protection is incorrectly adjusted, inadmissibly high strain may occur in case of lifting a load above the admissible carrying capacity.

- ▶ Loosen the cover screw (2) at the housing.
- ▶ Loosen the retaining screw in order to reach the threaded lug underneath.
- ▶ Turn the threaded lug to adjust the overload protection. Turn the lug clockwise to increase the shutoff setting, or counterclockwise to decrease the setting.
- ▶ Replace the retaining screw and tighten it down before testing the overload protection for correct functioning.
- ▶ Replace the cover screw (2) at the housing.

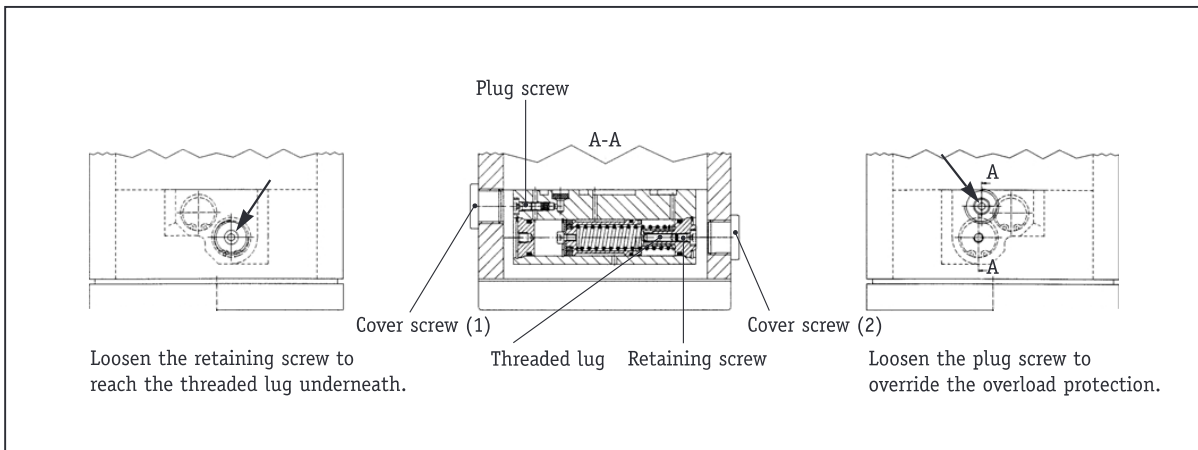

Overload protection (in the motor housing)



J.D. NEUHAUS

powered by air

ANNEX

TECHNICAL DATA

Type		B 24		B 48		B 612		M 64		M 63 D		M 77
Load capacity (rated load)	t	1.6/1.6	1.6/3.2	4/4	4/8	6/6	6/12	1/1	1/2	3/3	3/6	12/12
Number of chain falls		1/1	1/2	1/1	1/2	1/1	1/2	1/1	1/2	1/1	1/2	1/1
Standard lift	m	5	5/2.5	5	5/2.5	5	5/2.5	5	5/2.5	5	5/2.5	3
Lifting speed at rated load	m/min	3.5	3.5/1.7	1.7	1.7/0.8	1.1	1.1/0.5	3	3/1.5	2.2	2.2/1.1	1.2
Lifting speed without load	m/min	8	8/4	4.2	4.2/2.1	3	3/1.5	8	8/4	5	5/2.5	2.7
Lowering speed at rated load	m/min	9	9/4.5	5.8	5.8/2.9	3.8	3.8/1.9	12.5	12.5/6.5	6	6/3	4
Weight with E control/standard lift	kg	-	-	-	-	-	-	52	56	76	96	268
Weight with PS control/standard lift	kg	-	-	107	118	166.5	195	-	-	84.5	103.5	-
Weight with DS control/standard lift	kg	65	69	102	117	169	192	56	60	80	100	265
Control length with standard lift	m	2		2		2		2		2		2
Chain dimensions (DIN 5684-8)	d x t (mm)	9 x 27		13 x 36		16 x 45		9 x 27		13 x 36		22 x 66
Weight of chain	kg/m	1.8		3.8		5.8		1.8		3.8		10.8
Air pressure	bar	4		4		4		4		4		4
Air consumption at rated load	Lifting Lowering m ³ /min	1.7		2.3		2.3		1.0		2.2		3.1
		2.4		3.5		3.5		2.0		3.2		6.5
Air connection	rounded thread	Rd 32 x 1/8"		Rd 32 x 1/8"		Rd 32 x 1/8"		Rd 32 x 1/8"		Rd 32 x 1/8"		Rd 38 x 1/8"
Size of hose	mm	NW 20		NW 20		NW 20		NW 20		NW 20		NW 25
Motor output	kW	1		1.5		1.5		0.77		1.3		4
Sound emission at rated load (sound level record)	Lifting Lowering dB (A)	76		76		79		75		79		83
		78		84		86		84		83		90



DIMENSIONS

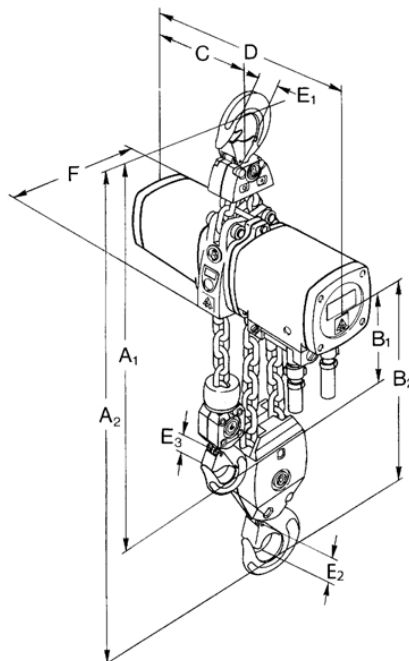

Type		B 24	B 48	B 612	M 64	M 63 D	M 77
A ₁ (minimum height overall with 1/1 chain falls)	mm	608	772.5	920	603	750	1150
A ₂ (minimum height overall with 1/2 chain falls)	mm	651	812	998	660	870	-
B ₁ (with 1/1 chain falls)	mm	310	418	462	313	370	585
B ₂ (with 1/2 chain falls)	mm	353	457.5	540	370	490	-
C	mm	230	286.5	330	175	237	376
D	mm	465	577	635	375	507	736
E ₁ (Hook jaw width)	mm	30	40	42	30	40	42
E ₂ (Hook jaw width)	mm	30	40	42	30	40	42
E ₃ (Hook jaw width)	mm	30	30	40	30	30	42
F (Maximum width)	mm	146	182	232	144	195	350



J.D. NEUHAUS

powered by air
powered by air



BA 901 GB · Issue: November 2002 · Alterations reserved · With the issue of this edition all previous versions are null and void · 11200205

J.D. Neuhaus GmbH & Co. KG_D-58449 Witten-Heven
Phone: +49(0)23 02-2 08-0_Fax: +49(0)23 02-2 08-286
web site: www.jdn.de_e-mail: info@jdn.de



J. D. NEUHAUS

powered by air
powered by air