



Lifting and Moving Solutions



www.gksweb.com

OPERATING INSTRUCTIONS NO.11/14 FOR REMOTE-CONTROLLED, BATTERY-OPERATED TRANSPORT SYSTEM **ROBOT 40**

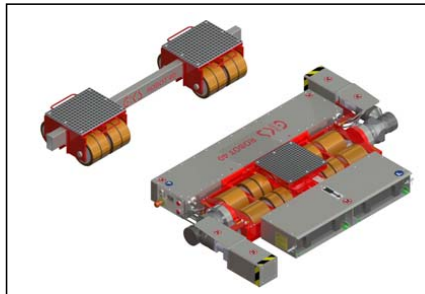

GENERAL INFORMATION

A battery driven steering dolly paired with an F- Dolly, and together they form a unit, which allows one person to transport a load of 40 tonnes using a remote control.
Due to the small turning circle, you can transport your heavy loads easily and safely anywhere you want.

TECHNICAL DATA

L-ROBOT (driven steering)		F-ROBOT (movable, nondriven)	
Article number 14007		Article number 14012	
Maximum capacity load	44,000 lbs.(20t)	Maximum capacity load	44,000 lbs.(20t)
Installation height	9.84"	Installation height	9.84"
Supporting surface	12,6x12,6"	Supporting surface (PA-rollers)	8.7 x 11" (2x)
		Supporting surface (PUR-rollers)	14.9 x 12.2" (2x)
Tare weight	1014 lbs.	Tare weight	PA: 220 lbs. RUR: 300 lbs.
External dimensions (LxBxH)	68.6 x 45.4 x 9.8"	External dimensions (LxBxH)	11 x 63 x 9.8"

TEST CERTIFICATE



GKS-LIFTING AND MOVING SOLUTIONS LLC

300 East Auburn Avenue
Springfield, OH 45505
USA

Tel.: +1(937)324-8867
Fax : +1(937)324-8171
E-mail : info@gks-web.com
Internet : www.gks-web.com

TABLE OF CONTENTS

Page

Technical Data	1
Scope of Supply, Operating Conditions	2
General and Special Safety Information	3,4
Operational Steps	5
Commissioning	6,7
Maintenance	8
Battery Charger	9
Synchronization of Remote Control	10,11
Safety Information on the Rechargeable Battery charger	12 ... 14
Warranty	15,16
Service, Declaration of Conformity	17
Appendix 1: Circuit diagram	





Lifting and Moving Solutions

GPERFECTKS®

www.gksweb.com

**OPERATING INSTRUCTIONS NO.11/14 FOR REMOTE-CONTROLLED; BATTERY-OPERATED
TRANSPORT SYSTEM ROBOT 40**

SCOPE OF SUPPLY

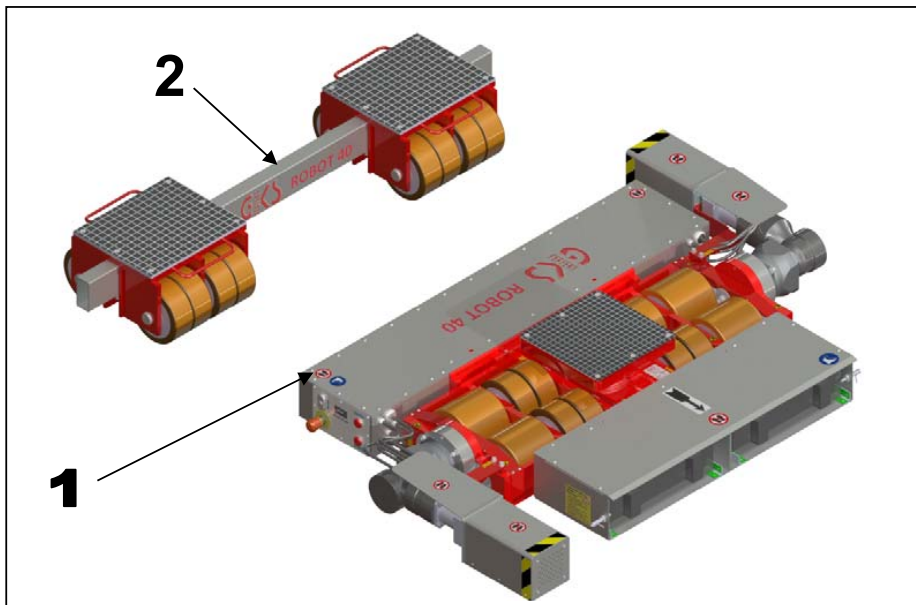

1. L-ROBOT (driven steering)
2. F-ROBOT (movable, nondriven)
3. Charger for battery of propulsion (2x)
4. Remote control with transmitter battery and charger
5. Operating instructions

OPERATING AND STORAGE CONDITIONS

- -20°C to +40°C
- 90% humidity at 25°C
- IP33 class of protection (remote control transmitter IP65)

**SCOPE OF SUPPLY
OPERATING AND
STORAGE CONDITIONS**



Lifting and Moving Solutions



www.gksweb.com

**OPERATING INSTRUCTIONS NO.11/14 FOR REMOTE-CONTROLLED, BATTERY-OPERATED
TRANSPORT SYSTEM **ROBOT 40****

**ALWAYS KEEP THE OPERATING INSTRUCTIONS CLOSE AT HAND
WHEN ROBOT IS IN USE!**

Dear customer,
always read this guide carefully before using your transport dolly
for the first time!

GENERAL SAFETY INFORMATION

The specifications of the German Accident Prevention Regulations (UVV) BGV D 27 always apply

Safety area: This includes the load, the area immediately around the load as well as an appropriately large additional distance such that no damage to property or personal injury can arise if the heavy load tips. The operating personnel must ensure that no unauthorized people are located in the safety area!

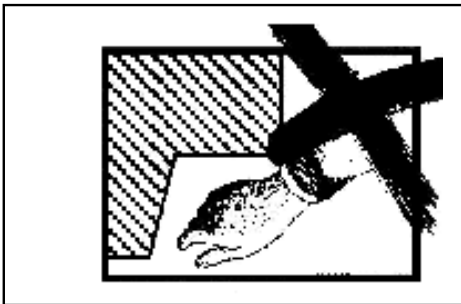

You must never have parts of your body, such as your hands, arms or feet under the load!



You must pay attention to protruding parts and attachments to avoid head injuries, for example!

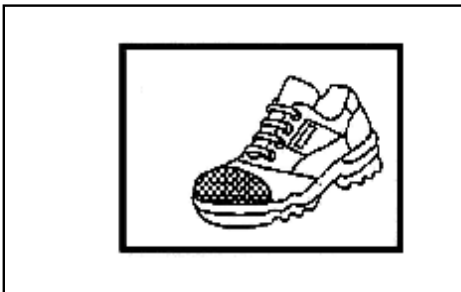

Operating personnel must always wear safety shoes with steel toecaps!

The operating personnel must receive appropriate orientation.



Lifting and Moving Solutions



www.gksweb.com

**OPERATING INSTRUCTIONS NO.11/14 FOR REMOTE-CONTROLLED, BATTERY-OPERATED
TRANSPORT SYSTEM ROBOT 40**

SPECIAL SAFETY INFORMATION

Before deploying the GKS-Perfekt transport dolly Type ROBOT 40, you must check the weight of the load to be lifted and the condition of the floor. Apart from this, you must comply with the accident prevention regulations that apply at the place of use.

- Use only for factory-internal transportation
- Protect the equipment from wet or damp conditions
- Before using the dolly and the drive modules, check them for visible defects
- Do not overload the transport dollies and the steering dollies, even with a off-centre load you must not exceed the permissible maximum capacity load of the individual steering dollies
- Only use the transport and steering dollies on firm, level surfaces
- On non-level surfaces, the dollies and the objects to be lifted must be firmly connected to one another – there are threaded holes in the supporting surfaces of the dollies.
- There is no braking equipment installed in the dollies; when parking on sloping surfaces, you must secure the dollies from rolling away
- No travel on upward or downward slopes
- Dollies must always stand parallel to one another and to the heavy load.
- Never use F-dollies without a connecting bar! If you use the device without a connecting bar, this can damage the rollers!
- Check whether there is other radio remote-controlled equipment in the vicinity
- It is absolutely forbidden to ride on the material being transported!
- The operator must always be within line of sight of the load.
- In unclear situations, there must be another person present to act as a pathfinder.
- If work is interrupted, you must switch off the main switches on the drive modules.

All liability claims in the case of damage to property or personal injury are excluded if this is due to one or more of the following causes:

- Noncompliance with the information in the Operating Instructions and in the Accident Prevention Regulations
- Unauthorized structural changes
- Inadequate monitoring of parts that are subject to wear
- Repairs that are carried out incorrectly
- Inappropriate use of the propulsion modules or the transport and steering dollies

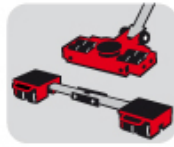
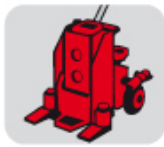

Lifting and Moving Solutions

www.gksweb.com

**OPERATING INSTRUCTIONS NO.11/14 FOR REMOTE-CONTROLLED, BATTERY-OPERATED
TRANSPORT SYSTEM **ROBOT 40****

SPECIAL SAFETY INFORMATION

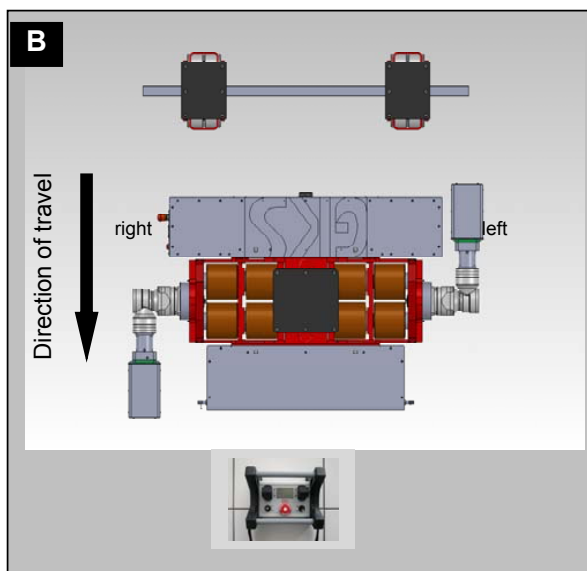
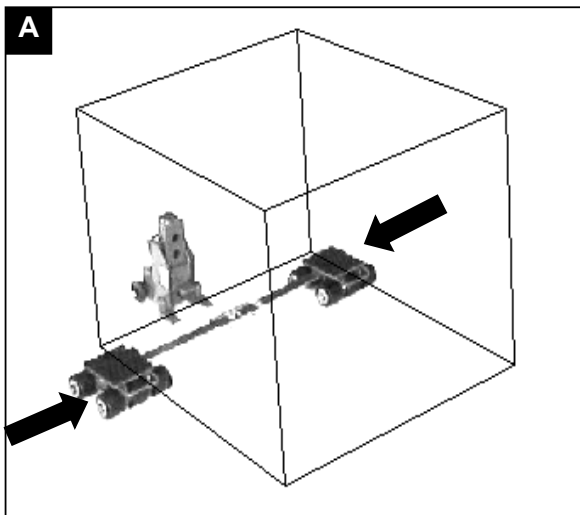

OPERATING STEPS

⚠ **Observe the section entitled "Control"! (Page 17)**

LOADING (Figure A / B)

- Determine the weight of the load
 - Choose a suitable toe jack
- We recommend our GKS-PERFEKT hydraulic jacks**
- Set the fixed dolly to the necessary distance
 - Raise the heavy cargo at the back and supporting
 - Push the movable transport dolly (nondriven) under the material to be lifted.
 - ⚠ **Do not reach under the suspended load!**
The supporting plates of the dollies must not protrude over the edges of the heavy cargo.
 - Place the heavy cargo on slowly and not in a shocklike way
 - If the floor is uneven, secure the dollies from rolling away before placing the next toe jack in position
 - Raise the heavy cargo at the front
 - Push the steering dolly under the material to be lifted.
 - ⚠ **Do not reach under the suspended load!**
You must push the steering dollies swivel top in the centre below the heavy cargo.



Lifting and Moving Solutions

GPERFEKT
KS®

www.gksweb.com

**OPERATING INSTRUCTIONS NO.11/14 FOR REMOTE-CONTROLLED BATTERY-OPERATED
TRANSPORTSYSTEM **ROBOT 40****

COMMISSIONING A

- Unlock EMERGENCY STOP at the L-ROBOT
- Switch on the L-ROBOT

You must keep to this order! Continue with commissioning B

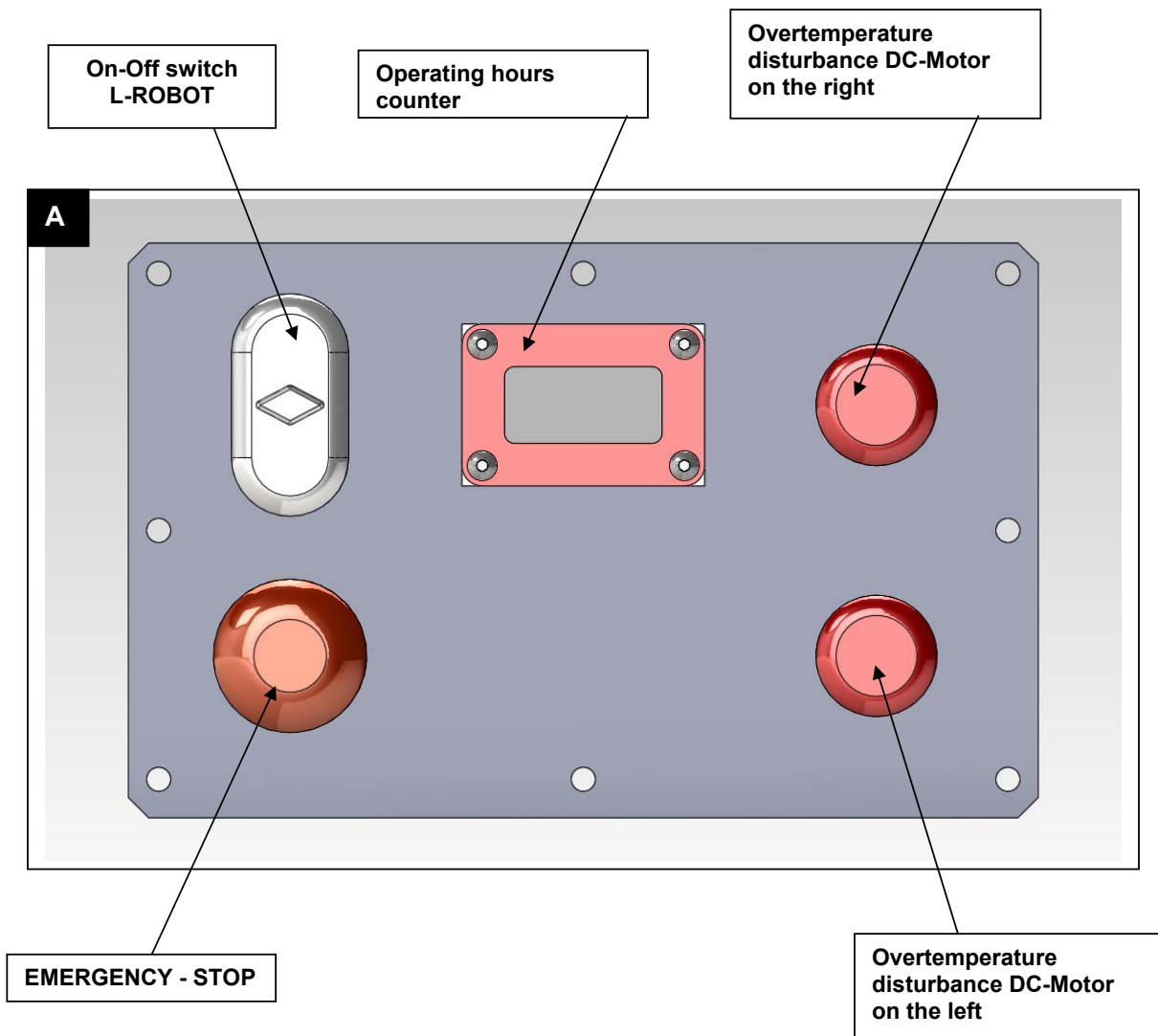



Lifting and Moving Solutions



www.gksweb.com

**OPERATING INSTRUCTIONS NO.11/14 FOR REMOTE-CONTROLLED, BATTERY-OPERATED
TRANSPORT SYSTEM **ROBOT 40****



COMMISSIONING B-C

- Insert keyswitch of transmitter
- Unlock EMERGENCY stop
- Switch on the remote control
- Choose the running step (3 or 6 m/min)
- Traverse the heavy cargo using both direction of travel and speed controllers taking into account all the safety information.

You must keep to this order!

⚠ The first time you push the button, you must check whether there is a mutual influence to or from other radio remote-controlled devices. If there is, you must immediately switch off the radio remote-control transmitter (using the stop switch). If you switch on again, the system automatically chooses a different frequency.

⚠ Never leave the transmitter unsupervised during operation and prevent unauthorized persons from operating it!

Transmitter of radio remote-control C

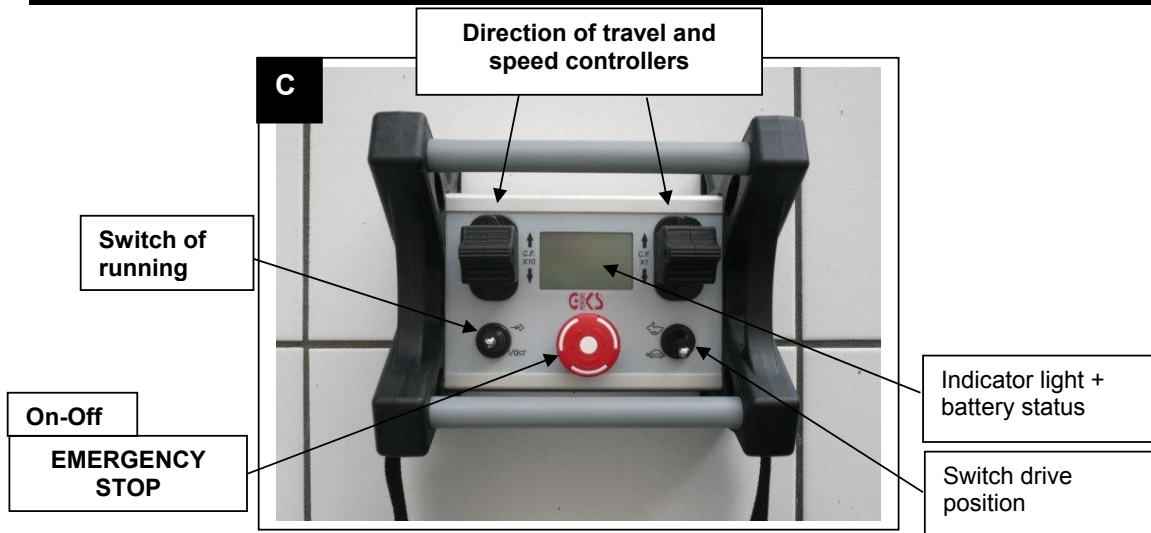

Please have a look at the added operating instructions „Radio remote-control“



Lifting and Moving Solutions

GKKS[®]
PERFECT

www.gksweb.com

**OPERATING INSTRUCTIONS NO.11/14 FOR REMOTE-CONTROLLED, BATTERY-OPERATED
TRANSPORT SYSTEM ROBOT 40**

Continued: OPERATIONAL STEPS

- F**  In the case of emergencies or irregularities, you must always press the red **EMERGENCY STOP** switch on the transmitter!



EMERGENCY
STOP

UNLOADING/SWITCHING OFF

- Switch off the ON-OFF switch on the remote-control transmitter
- Do not switch off the main switch (ON-OFF) on **both drive modules** until approximately **five minutes** of runtime have elapsed.
- on an uneven surface, secure the dollies from rolling away
- Raise the load on the front side
- First remove the steering dolly
-  **Do not reach under a suspended load!**
- Raise the load on the back and remove the F-ROBOT
- Lower the load with the hydraulic jacks

MAINTENANCE

- Check the battery charge status
- Check all the components for external damage
- If there are any other irregularities, please contact your supplier
- Lubricate the roller bearings every two months using roller bearing grease (e.g.FAG Arcanol or DIN51825 Class KP-standard greases)

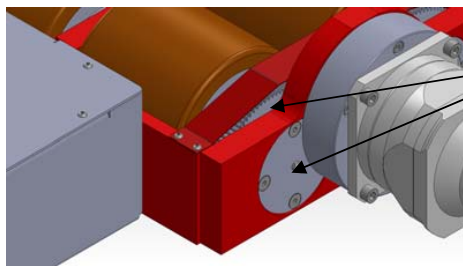

Lubricating
point

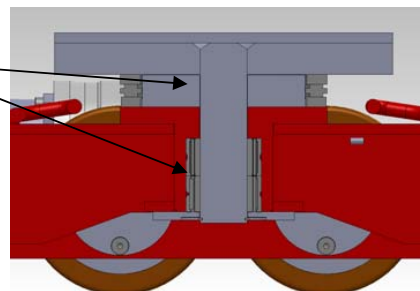

- Check that the bolts and nuts are tightened securely (before each use)
- Battery charge look at page 9ff
- Check the rollers for wear (before each use)



Lifting and Moving Solutions



www.gksweb.com

**OPERATING INSTRUCTIONS NO.11/14 FOR REMOTE-CONTROLLED, BATTERY-OPERATED
TRANSPORT SYSTEM **ROBOT 40****

CHARGER



Charger for internal Li-Polymer battery of L-ROBOT



Charger for transmitter battery of radio remote-control

Connector





Lifting and Moving Solutions



www.gksweb.com

**OPERATING INSTRUCTIONS NO.11/14 FOR REMOTE-CONTROLLED, BATTERY-OPERATED
TRANSPORT SYSTEM **ROBOT 40****

REMOTE CONTROL

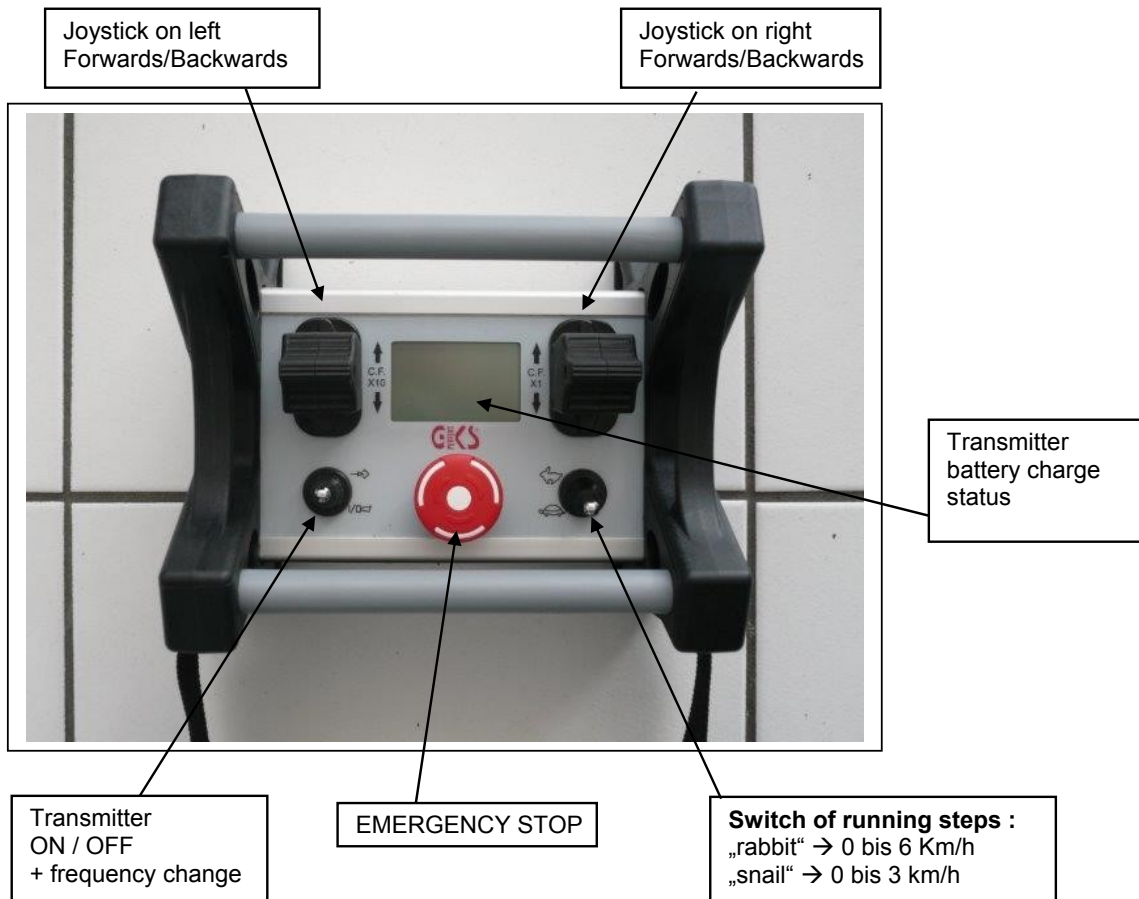



Lifting and Moving Solutions



www.gksweb.com

**OPERATING INSTRUCTIONS NO.11/14 FOR REMOTE-CONTROLLED, BATTERY-OPERATED
TRANSPORT SYSTEM ROBOT 40**



Akkubox type AA



Lifting and Moving Solutions



www.gksweb.com

OPERATING INSTRUCTIONS NO.11/14 FOR REMOTE-CONTROLLED, BATTERY-OPERATED TRANSPORT SYSTEM ROBOT 40

Special safety information on the rechargeable battery:

- Use the rechargeable battery for its intended purpose only.
- When charging, use only our charger that is supplied with sets; maximum charging current 5A, we accept no liability whatsoever for any other chargers.
- Only use the rechargeable batteries in a housing.
- You are prohibited from opening or working on the housing or the rechargeable battery.
- You must not deform the housing or the rechargeable battery.
- Only authorized specialists are allowed to carry out installation.
- You are prohibited from short-circuiting the rechargeable battery.
- You must not throw the rechargeable battery.
- Do not allow the rechargeable battery to come into contact with liquids.
- Keep the rechargeable battery away from sources of heat (keep out of direct sunlight), do not put it in a fire.
- Dispose of the battery at battery collection facilities.
- The product is not edible.
- Store the product away from children aged less than 12.

Charging/discharging: Lithium Polymer (LiPo) rechargeable batteries represent a new technical standard. LiPo rechargeable batteries are particularly sensitive to being over- or under-charged. This means that our rechargeable batteries are fitted with an electronic LiPo Power Management System. This protective module prevents the LiPo cells from being over- or under-charged; this means that you must **under no circumstances** remove this module, since this would mean that safe operation could no longer be guaranteed.

You must only ever charge the rechargeable battery under supervision, on a non-flammable, non-conductive, and heat-resistant surface!

Misuse, such as using the wrong charger, breaking the battery, damaging the battery or deformation, can result in danger of explosions, fire, smoke, and contamination. The maximum charge current is 5A.

Balancer: A balancer is integrated in the LiPo Power Management System. This guarantees that, after charging, all the cells are matched to the same voltage level. This means that your rechargeable battery will have excellent yield capacity over a long service life.

Storage: Charge the rechargeable battery to approximately 50% of capacity. Check the charge status about every 2-3 months; store it in a cool dry place at room temperature.

Extinguishing information:

You must extinguish burning LiPo rechargeable batteries using extinguishing powder, sand or similar extinguishants. Never use water, since the lithium that is contained in the LiPo cell reacts with the water. This can result in an explosion or similar.



Lifting and Moving Solutions



www.gksweb.com

OPERATING INSTRUCTIONS NO.11/14 FOR REMOTE-CONTROLLED, BATTERY-OPERATED TRANSPORT SYSTEM **ROBOT 40**

Important information on using your Lithium-Polymer charger

Liability exclusion statement: We are not able to monitor your compliance with this information and the conditions and methods of operation under which you use the charger. This means that we can accept no liability whatsoever for any losses, damage, or costs arising from or in the context of faulty use and operation.

Safety information: (the guarantee is void if you do NOT comply with the specified safety information):

- Only use the charger to charge rechargeable batteries with an integrated LMS protective system.
- Use the charger for its intended purpose only.
- You are prohibited from opening or working on the housing or the cable.
- You must not deform the housing or the connecting cable.
- You are prohibited from short-circuiting the charger.
- You must not throw the charger.
- Do not allow the charger to come into contact with liquids.
- Keep the charger away from sources of heat (keep out of direct sunlight), do not put it in a fire.
- The product is not edible.
- Store the product away from children aged less than 12.

Use: Using this Lithium Polymer charger, you are only allowed to charge our rechargeable batteries. Please note that this charger is not suitable for model-making Lithium Polymer cells and preassembled packages.

The rechargeable batteries to be charged must have a built-in protective circuit.

Connection: As standard, this charger is supplied with two terminals. The terminals are labelled as follows:

Red terminal: + Plus

Black terminal: - Minus

Alternative version with charging plug: the plug can only be inserted in the correct position!

Display: Using the display, you can establish whether the charger is operating.

LED lit up green: No rechargeable battery is connected or the battery is fully charged

LED lit up red: The rechargeable battery is being charged

Storage: Store the charger disconnected from the supply in a cool, dry place; the rechargeable battery must only be connected during charging; always store the rechargeable battery and the charger separate from one another with the rechargeable battery disconnected.



Lifting and Moving Solutions



www.gksweb.com

**OPERATING INSTRUCTIONS NO.11/14 FOR REMOTE-CONTROLLED, BATTERY-OPERATED
TRANSPORT SYSTEM **ROBOT 40****

Important information on using your Lithium-Polymer charger

Charging:

The period of charging (rest capacity 20%) is:

- with 1,5A – Battery charger 32 hours
- with 5,0A - Battery charger 12 hours (standard device, art.-no. 13419)
- with 12 A – Battery charger 5 hours
- with 18 A – Battery charger 3,5...4 hours (optional available art.-no. 13631)

standard charge rate 12A

Caution: only - use - original – battery - charger – from - GKS.



Lifting and Moving Solutions



www.gksweb.com

**OPERATING INSTRUCTIONS NO.11/14 FOR REMOTE-CONTROLLED, BATTERY-OPERATED
TRANSPORT SYSTEM **ROBOT 40****

WARRANTY

MECHANICAL SYSTEM/ELECTRICAL SYSTEM

As the manufacturer, Georg Kramp GmbH & Co.KG (referred to below as GKS) guarantees the object of the contract in accordance with the following provisions. The warranty starts on the day of delivery to the customer. The guarantee period is two years or 900 operating hours (whichever occurs first).

The warranty applies only to the purchaser named in the confirmation of order of GKS. Warranty claims are conditional on the customer immediately reporting any defects that occur in verifiable form to GKS. This must take place within, 14 days of the purchaser detecting the defect or after the point in time at which the defect becomes noticeable to the purchaser under normal usage of the object without close examination. The purchaser must include with their notification of defects appropriate evidence (photographs, sketches, descriptions of the damage, etc.).

In the case of a warranty claim, GKS is authorized to repair the delivered item a total of three times because of the same defect. Only after this repair by the manufacturer has failed is the purchaser entitled to replacement in the form of an equivalent delivered item. In the case of replacement, the manufacturer is entitled to supply the purchaser with a substitute item of an equivalent type and quality.

Parts subject to wear are excluded from the warranty. Any and all warranty claims are voided if – without the consent of the manufacturer – the purchaser has interfered with or modified the supplied products. If parts are installed that are not GKS original spare parts (third-party spares), this voids any warranty claims. This also and specifically applies to the use of rechargeable batteries that are not original GKS products.

The purchaser's warranty claim is also voided in the case of incorrect treatment, natural wear, breaching the operating, assembly and maintenance regulations and using incorrect and unsuitable operating materials. GKS's costs and warranty performance are limited to repairing or replacing in the sense above. The purchaser bears any and all further costs of transportation, packaging, etc. GKS bears no follow-up costs whatsoever. Place of performance of warranty is Fellbach.



Lifting and Moving Solutions



www.gksweb.com

**OPERATING INSTRUCTIONS NO.11/14 FOR REMOTE-CONTROLLED, BATTERY-OPERATED
TRANSPORT SYSTEM **ROBOT 40****

WARRANTY

RECHARGEABLE BATTERY

Parts subject to wear are excluded from the warranty. Any and all warranty claims are voided if – without the consent of the manufacturer – the purchaser has interfered with or modified the supplied products. If parts are installed that are not GKS original spare parts (third-party spares), this voids any warranty claims. This also and specifically applies to the use of rechargeable batteries that are not original GKS products.

If the safety information is complied with, the warranty period for Lithium-Polymer rechargeable batteries is one year with a maximum of 300 cycles and a maximum depth of discharge (DOD) of 80%.



Lifting and Moving Solutions

GKS
PERFEKT®

www.gksweb.com

**OPERATING INSTRUCTIONS NO.11/14 FOR REMOTE-CONTROLLED, BATTERY-OPERATED
TRANSPORT SYSTEM **ROBOT 40****

OTHER INFORMATION

SERVICE, REPAIRS AND ORDERING SPARE PARTS

- **Service/spare parts lists and ordering spare parts:**
For information and to order spare parts please call our

SERVICE NUMBER:

Phone: +1 (937)324 - 8867

Fax : +1 (937)324 - 8171

E-mail: info@gksweb.com

- **Repairs**
After giving you an estimate, we will carry out any necessary maintenance and repair work quickly and professionally. Send your device to us.

INSPECTION

Before **every use**, you must carry out a visual inspection on the transport and steering dollies:

- Inspect the weld seams
- Check for deformation of the trolley cassette, and the connecting bar
- Check the rollers for wear and dirt
- If the rollers are wearing unevenly, you must replace them on a cassette-by-cassette basis

SPECIAL DESIGNS

Our Design Department implements customer-specific lifting and moving systems and provides solutions for any heavy load-moving problems. Let us know how we can help you.

EC DECLARATION OF CONFORMITY

We hereby declare that the GKS-PERFEKT transport dollies of types:

ROBOT 40

for factory-internal transportation of machines and heavy cargo conform to the following relevant provisions:

- Directive 2006/42/EC of the European Parliament and Commission dated 17 May 2006, Appendix II A

Applicable international technical standards, in particular

- DIN EN ISO 12100: Safety of machines

Applicable national technical standards and specifications, in particular

- BGV D27: Accident prevention regulations for industrial trucks
- Machine Safety Code (GPSG)

Georg Kramp GmbH & Co. KG
GKS - PERFEKT Hebe- und Transportsysteme
Max-Planck-Str. 32
D 70736 Fellbach

Fellbach, 20.08.2014

Kramp



Lifting and Moving Solutions



www.gksweb.com

CIRCUIT DIAGRAM ON RIGHT

