



# OPERATION MANUAL

(800) 878-7305    Rentals@RentLGH.com    RentLGH.com

**HONDA**

**Power**

**Equipment**

## Owner's Manual GXV120 • 160

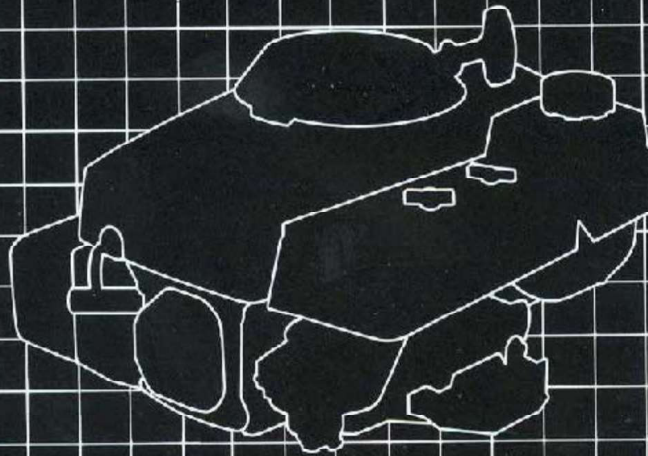

© HONDA MOTOR CO., LTD. 1985



## 2. COMPONENT IDENTIFICATION

---

GXV120

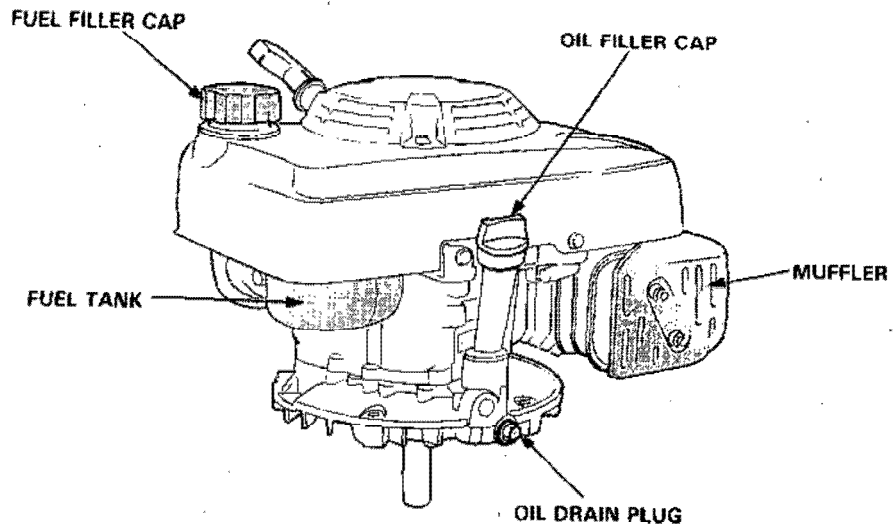
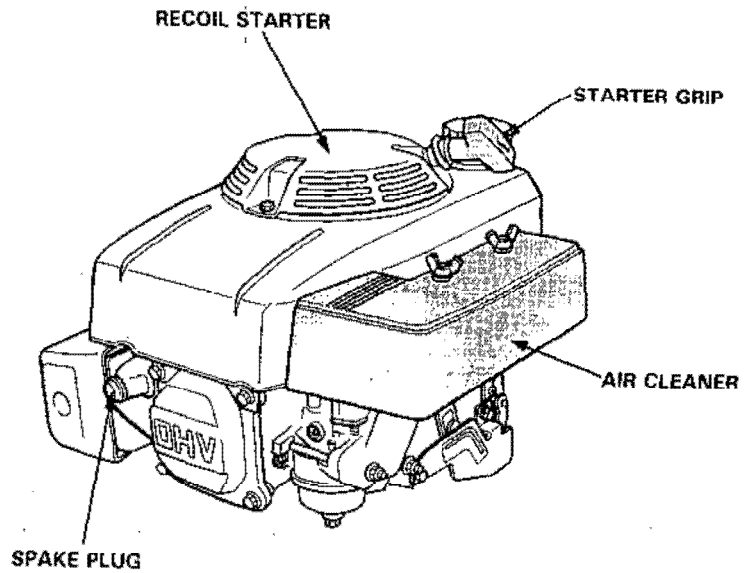

## CONTENTS

---

<del>1. SAFETY INSTRUCTIONS</del> .....	3
2. COMPONENT IDENTIFICATION .....	4
<del>3. BATTERY CONNECTIONS (for electric starter)</del> .....	6
4. PRE-OPERATION CHECK .....	7
5. STARTING THE ENGINE .....	11
<del>6. OPERATION</del> .....	13
7. STOPPING THE ENGINE .....	14
<del>8. MAINTENANCE</del> .....	15
9. TRANSPORTING/STORAGE .....	23
<del>10. TROUBLESHOOTING</del> .....	24
<del>11. SPECIFICATIONS</del> .....	26
• High altitude operation .....	27
<del>12. WARRANTY SERVICE</del> .....	28

# 1. SAFETY INSTRUCTIONS

---

## WARNING

To ensure safe operation —

- To prevent fire hazards and to provide adequate ventilation, keep the engine at least 3 ft away from buildings and other equipment during operation.
- Do not place flammable objects such as gasoline, matches, etc., close to the engine while it is running.
- Refuel in a well-ventilated area with the engine stopped. Gasoline is flammable and explosive under certain conditions.
- Do not overfill the tank. There should be no fuel in the filler neck. Make sure that the filler cap is closed securely.
- If any fuel is spilled, clean it up completely before starting the engine.
- Do not smoke or allow flames or sparks where the engine is refueled or where gasoline is stored.
- Exhaust gas contains poisonous carbon monoxide. Avoid inhalation of exhaust gases. Never run the engine in a closed garage or confined area.
- Operate the engine on a level surface. If the engine is tilted, fuel spillage may result.
- Do not place anything on the engine, as it may create a fire hazard.
- A spark arrester is available as an optional part for this engine. It is illegal in some areas to operate an engine without a spark arrester. Check local laws and regulations before operating.

## 2. COMPONENT IDENTIFICATION

---

GXV120

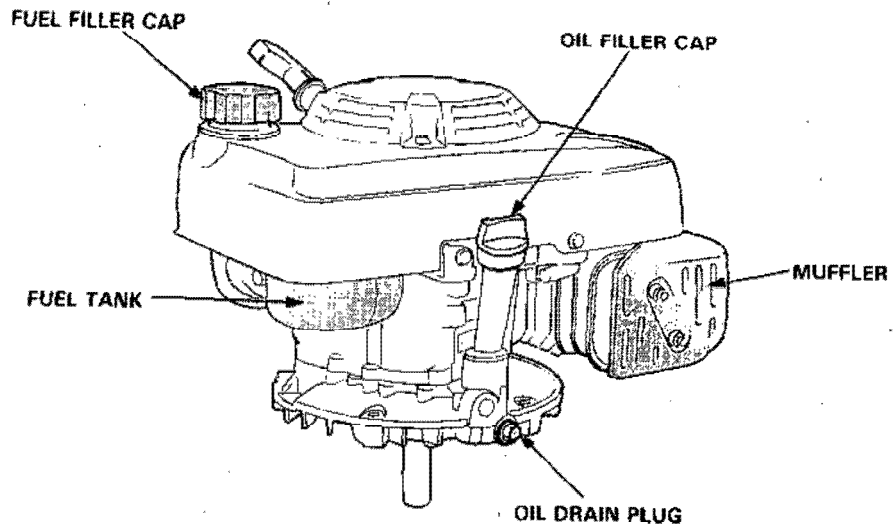
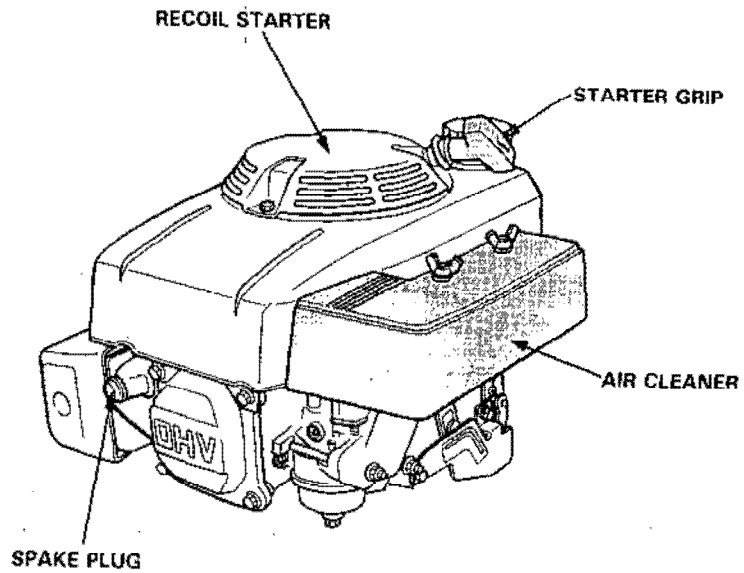

---

**GXV160**

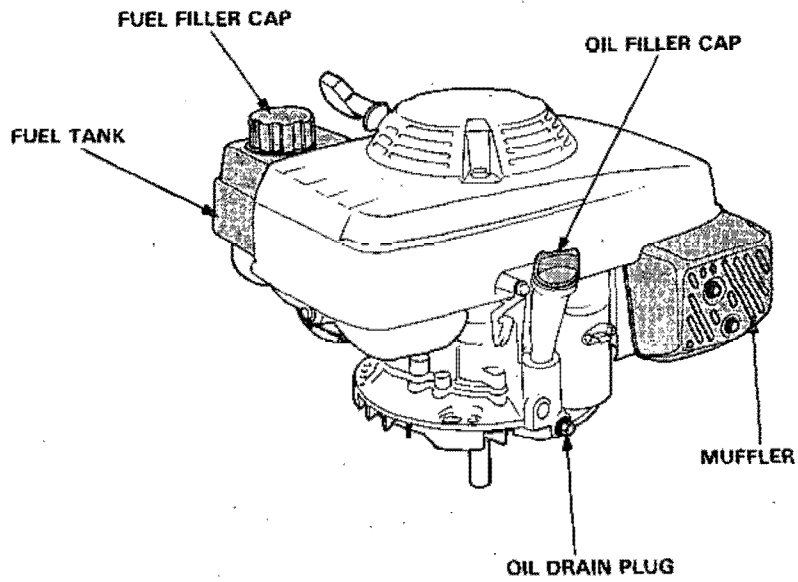
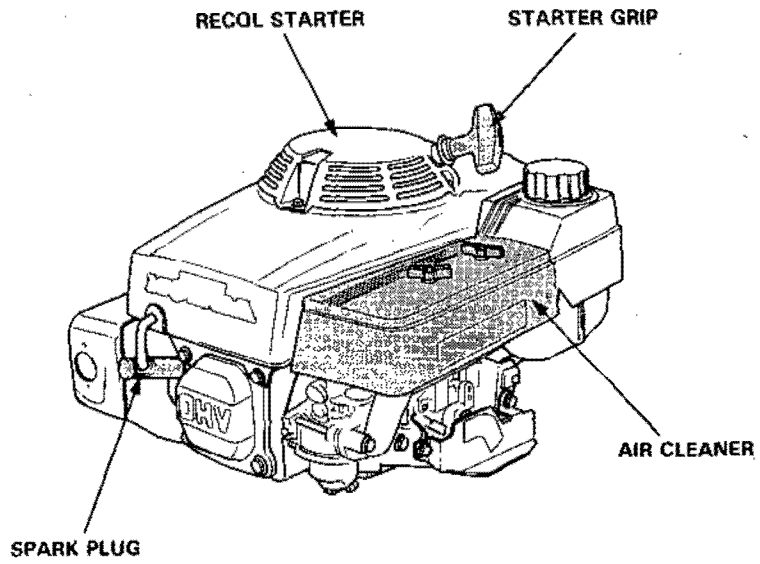

### **3. BATTERY CONNECTIONS (for electric starter)**

---

Use a 12 volt battery with an ampere-hour rating of at least 8 AH.

Connect the battery positive (+) cable to the starter solenoid terminal as shown.

Connect the battery negative (-) cable to an engine mounting bolt, frame bolt, or other good engine ground connection.

Check the battery cable connections to be sure the cables are secured and free of corrosion. Remove any corrosion and coat the terminals and cable ends with grease.

#### **WARNING**

- The battery gives off explosive gases; keep sparks, flames and cigarettes away. Provide adequate ventilation when charging or using batteries in an enclosed space.
- The battery contains sulfuric acid (electrolyte). Contact with skin or eyes may cause severe burns. Wear protective clothing and a face shield.
  - If electrolyte gets on your skin, flush with water.
  - If electrolyte gets in your eyes, flush with water for at least 15 minutes and call a physician immediately.
- Electrolyte is poisonous.
  - If swallowed, drink large quantities of water or milk and follow with milk of magnesia or vegetable oil and call a physician.
- **KEEP OUT OF REACH OF CHILDREN.**

#### **CAUTION:**

- Use only distilled water in the battery. Tap water will shorten the service life of the battery.
- Filling the battery above the **UPPER LEVEL** line may cause the electrolyte to overflow, resulting in corrosion to engine or nearby parts. Immediately wash off any spilled electrolyte.
- Do not connect the battery in reverse polarity as this will short circuit the battery charging system.

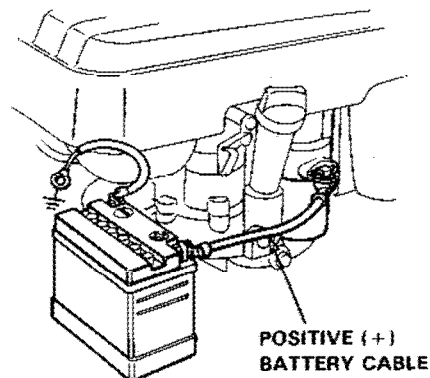

## 4. PRE-OPERATION CHECK

### 1. ENGINE OIL

#### CAUTION:

- Engine oil is a major factor affecting engine performance and service life. Non-detergent oils and vegetable oils are not recommended.
- Be sure to check the engine on a level surface with the engine stopped.

Use Honda 4-stroke oil or an equivalent high-detergent, premium quality motor oil certified to meet or exceed U.S. automobile manufacturer's requirements for Service Classification SE or SF. Motor oils classified SE or SF will show this designation on the container.

SAE 10W-40 is recommended for general, all-temperature use.

Other viscosities shown in the chart may be used when the average temperature in your area is within the indicated range.

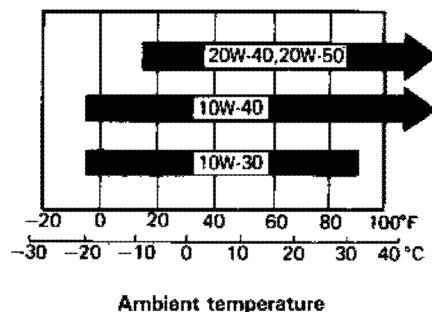

1. Remove the oil filler cap and wipe the dipstick clean.
2. Insert the dipstick into the oil filler neck but do not screw it in.
3. If the level is low, add the recommended oil to the upper mark on the dipstick.

**CAUTION:** Running the engine with insufficient oil can cause serious engine damage.

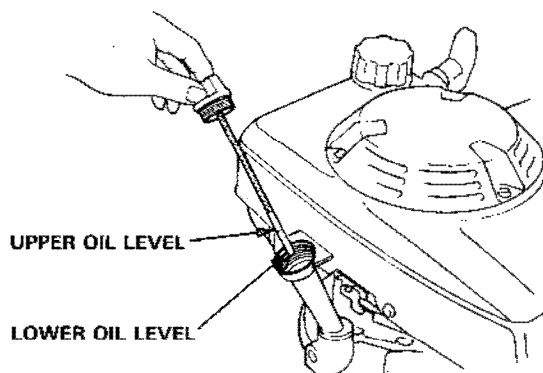

---

## 2. AIR CLEANER

Check the air cleaner elements to be sure they are clean and in good condition.

Clean or replace the elements if necessary (page 17).

**CAUTION:** Never run the engine without the air cleaner. Rapid engine wear will result.

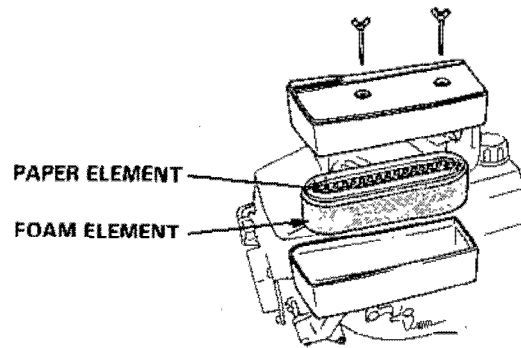

---

### 3. FUEL

Your engine is designed to use any gasoline that has a pump octane number  $(\frac{R+M}{2})$  of 86 or higher, or that has a research octane number of 91 or higher. Gasoline pumps at service station normally display the pump octane number.

We recommend that you use unleaded fuel because it produces fewer engine and spark plug deposits and extends the life of exhaust system components.

Never use stale or contaminated gasoline or an oil/gasoline mixture. Avoid getting dirt, dust or water in the fuel tank. Use of a lower octane gasoline can cause persistent "pinging" or heavy "spark knock" (a metallic rapping noise) which, if severe, can lead to engine damage.

**CAUTION:** If "spark knock" or "pinging" occurs at a steady engine speed under normal load, change brands of gasoline. If spark knock or pinging persists, consult your authorized Honda dealer. Failure to do so is considered misuse, and damage caused by misuse is not covered by Honda's Limited Warranty.

Occasionally you may experience light spark knock while operating under heavy loads. This is no cause for concern, it simply means your engine is operating efficiently.

**WARNING**

- Gasoline is extremely flammable and is explosive under certain conditions.
- Refuel in a well-ventilated area with the engine stopped. Do not smoke or allow flames or sparks in the area where the engine is refueled or where gasoline is stored.
- Do not overfill the fuel tank (there should be no fuel in the filler neck). After refueling, make sure the tank cap is closed properly and securely.
- Be careful not to spill fuel when refueling. Spilled fuel or fuel vapor may ignite. If any fuel is spilled, make sure the area is dry before starting the engine.
- Avoid repeated or prolonged contact with skin or breathing of vapor.  
**KEEP OUT OF REACH OF CHILDREN.**

Fuel tank capacity: GXV120 1.0l (0.26 US Gal, 0.22 Imp gal)  
GXV160 2.0l (0.53 US Gal, 0.44 Imp gal)

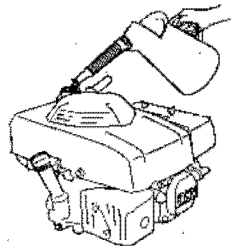

---

## **GASOLINES CONTAINING ALCOHOL**

If you decide to use a gasoline containing alcohol (gasohol), be sure it's octane rating is at least as high as that recommended by Honda. There are two types of "gasohol": one containing ethanol, and the other containing methanol. Do not use gasohol that contains more than 10% ethanol. Do not use gasoline containing methanol (methyl or wood alcohol) that does not also contain cosolvents and corrosion inhibitors for methanol. Never use gasoline containing more than 5% methanol, even if it has cosolvents and corrosion inhibitors.

### **NOTE:**

- Fuel system damage or engine performance problems resulting from the use of fuels that contain alcohol is not covered under the warranty. Honda cannot endorse the use of fuels containing methanol since evidence of their suitability is as yet incomplete.
- Before buying fuel from an unfamiliar station, try to find out if the fuel contains alcohol, if it does, confirm the type and percentage of alcohol used. If you notice any undesirable operating symptoms while using a gasoline that contains alcohol, or one that you think contains alcohol, switch to a gasoline that you know does not contain alcohol.

## 5. STARTING THE ENGINE

---

1. Turn the fuel valve to the ON position.

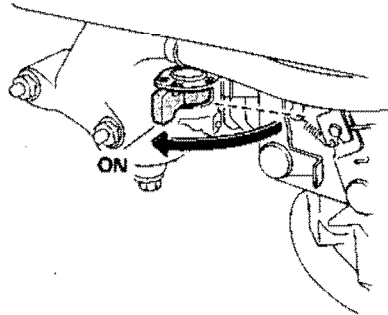

(GXV120)

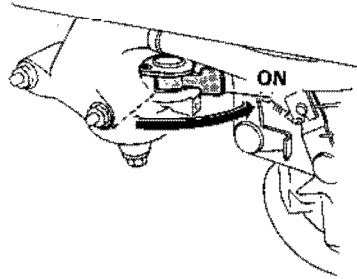

(GXV160)

2. Move the control lever to the CHOKE position.

Do not use the choke if the engine is warm or the ambient temperature is high.

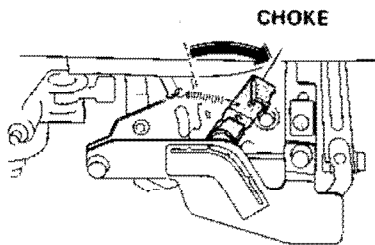

- 
- With recoil starter:  
Pull the starter grip lightly until resistance is felt, then pull briskly.

**CAUTION:** Do not allow the starter grip to snap back against the engine. Return it gently to prevent damage to the starter.

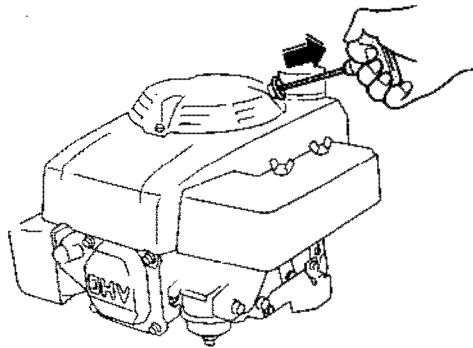

- With electric starter:  
Turn the engine switch to the **START** position and hold it there until the engine starts.

**NOTE:** Do not use the electric starter for more than 5 seconds at a time. If the engine fails to start, release the switch and wait 10 seconds before operating the starter again.

When the engine starts, allow the engine switch to return to the **ON** position.

## 6. OPERATION

---

When the engine warms up, move the control lever from the CHOKE position to the operating position for the desired engine speed.

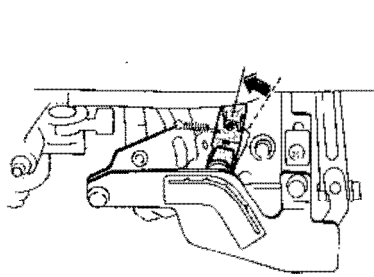

## 7. STOPPING THE ENGINE

---

1. Move the control lever to the STOP position.

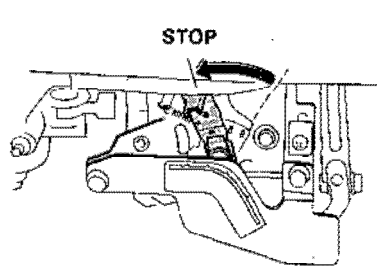

2. Turn the fuel valve to the OFF position.

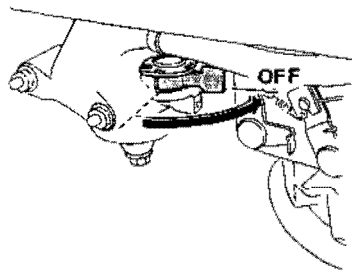

(GXV120)

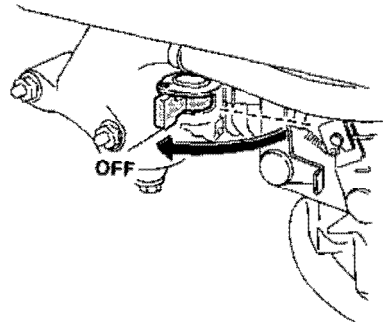

(GXV160)

## 8. MAINTENANCE

The purpose of the maintenance and adjustment schedule is to keep the engine in good operating condition. Inspect or service as scheduled in the table below.

**WARNING** Shut off the engine before performing any maintenance. If the engine must be run, make sure the area is well ventilated. The exhaust contains poisonous carbon monoxide gas.

**CAUTION:** Use only genuine HONDA parts or their equivalent. The use of replacement parts which are not of equivalent quality may damage the engine.

### Maintenance Schedule

REGULAR SERVICE PERIOD Performed at every indicated month or operating hour interval, whichever comes First.		Each use	First month or 20 Hrs.	Every 3 months or 50 Hrs.	Every 6 months or 100 Hrs.	Every year or 300 Hrs.
ITEM						
Engine oil	Check level	○				
	Change		○		○	
Air cleaner	Check	○				
	Clean			○(1)		
Flywheel brake pad	Check (Replace if necessary)			○(2)		
Spark plug	Clean-Readjust				○	
Spark arrester (optional part)	Clean				○	
Valve clearance	Check-Readjust					○(2)
Fuel tank and strainer	Clean					○(2)
Fuel line	Check (Replace if necessary)		Every 3 years (2)			

NOTE: (1) Service more frequently when used in dusty areas.

(2) These items should be serviced by an authorized Honda dealer, unless the owner has the proper tools and is mechanically proficient. See the Honda Shop Manual.

---

## 1. Oil change

Drain the oil while the engine is still warm to assure rapid and complete draining.

1. Remove the oil filler cap and drain plug to drain the oil.
2. Install the drain plug and tighten it securely.
3. Refill with the recommended oil (see page 7) and check the oil level.
4. Install the oil filler cap.

**ENGINE OIL CAPACITY: GXV120 0.6 l (0.63 US qt, 0.53 Imp qt)  
GXV160 0.65 l (0.69 US qt, 0.57 Imp qt)**

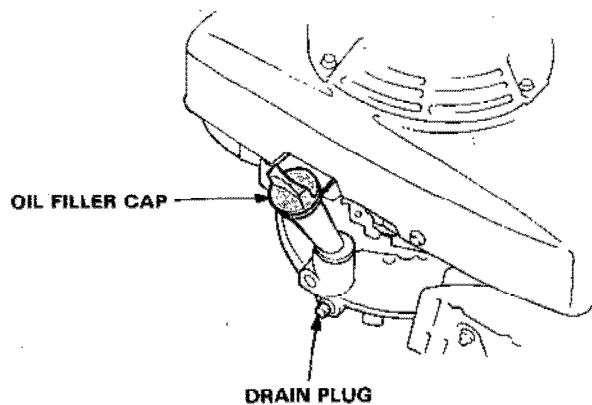

**CAUTION:** Used motor oil may cause skin cancer if repeatedly left in contact with the skin for prolonged periods. Although this is unlikely unless you handle used oil on a daily basis, it is still advisable to thoroughly wash your hands with soap and water as soon as possible after handling used oil.

**NOTE:** Please dispose of used motor oil in a manner that is compatible with the environment. We suggest you take it in a sealed container to your local service station for reclamation. Do not throw it in the trash or pour it on the ground.

---

## 2. Air cleaner service

A dirty air cleaner will restrict air flow to the carburetor. To prevent carburetor malfunction, service the air cleaner regularly. Service more frequently when operating the engine in extremely dusty areas.

**WARNING** Never use gasoline or low flash point solvents for cleaning the air cleaner element. A fire or explosion could result.

**CAUTION:** Never run the engine without the air cleaner. Rapid engine wear will result.

1. Remove the wing nut and the air cleaner cover. Remove the elements and separate them. Carefully check both elements for holes or tears and replace if damaged.
2. Foam element: Wash the element in a solution of household detergent and warm water, then rinse thoroughly, or wash in nonflammable or high flash point solvent. Allow the element to dry thoroughly. Soak the element in clean engine oil and squeeze out the excess oil. The engine will smoke during initial start-up if too much oil is left in the foam.
3. Paper element: Tap the element lightly several times on a hard surface to remove excess dirt, or blow compressed air through the filter from the inside out. Never try to brush the dirt off; brushing will force dirt into the fibers. Replace the paper element if it is excessively dirty.

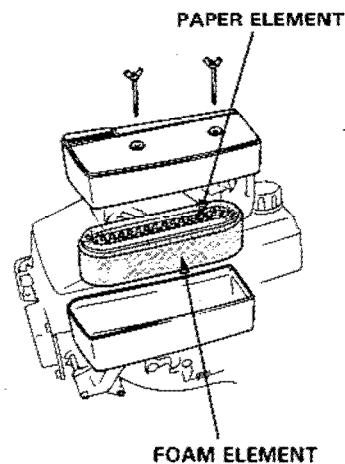

---

#### 4. Spark plug service

Recommended spark plug: **BP5ES, BPR5ES (NGK)**  
**W16EP-U, W16EPR-U (ND)**

**CAUTION:** Never use a spark plug of incorrect heat range.

To ensure proper engine operation, the spark plug must be properly gapped and free of deposits.

1. Remove the spark plug cap and use a spark plug wrench to remove the plug.

**WARNING** If the engine has been running, the muffler will be very hot. Be careful not to touch the muffler.

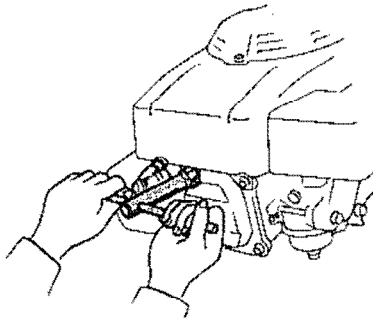

2. Visually inspect the spark plug. Discard it if the insulator is cracked or chipped. Clean the spark plug with a wire brush if it is to be reused.
3. Measure the plug gap with a feeler gauge. The gap should be 0.7–0.8 mm (0.028–0.031 in). Correct as necessary by bending the side electrode.

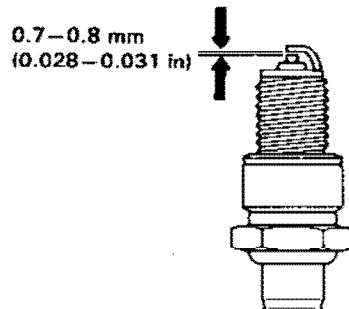

- 
4. Check that the spark plug washer is in good condition and thread the spark plug in by hand to prevent cross-threading.

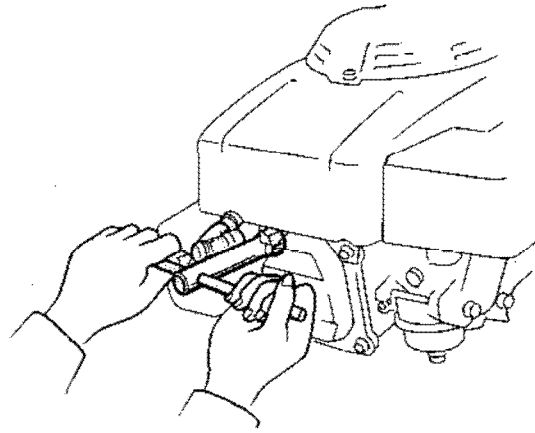

5. After the spark plug is seated, tighten with a spark plug wrench to compress the washer.

**NOTE:** When installing a new spark plug, tighten  $1/2$  turn after the spark plug seats to compress the washer. When reinstalling a used spark plug, tighten  $1/8 - 1/4$  turn after the spark plug seats to compress the washer.

**CAUTION:** The spark plug must be securely tightened. An improperly tightened spark plug can become very hot and may damage the engine.

---

## 5. Spark arrester maintenance (optional part)

**WARNING** If the engine has been running, the muffler will be very hot. Allow it to cool before proceeding.

1. Loosen the three 6 mm nuts and remove the muffler protector, identification plate, muffler and gasket.
2. Remove the spark arrester from the muffler (take care not to damage the wire mesh).

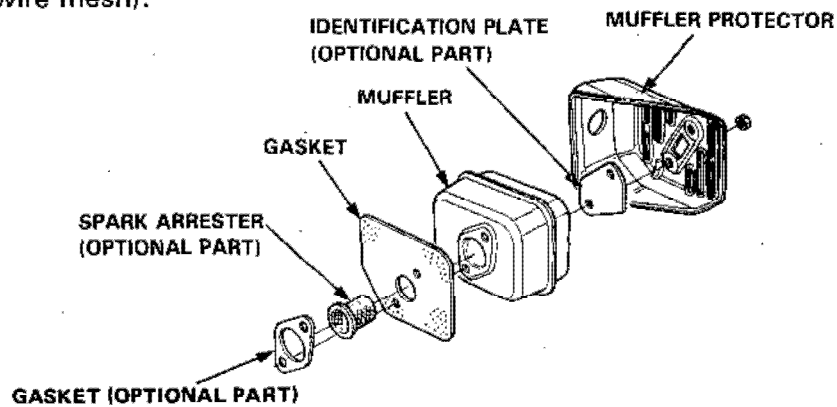

3. Use a brush to remove carbon deposits from the spark arrester screen.

**CAUTION:** Be careful not to damage the spark arrester screen.



**NOTE:** The spark arrester must be free of breaks and holes. Replace, if necessary.

4. Install the spark arrester and the muffler in the reverse order of disassembly.

---

## 6. Carburetor adjustment

1. Start the engine and allow it to warm up to normal operating temperature.
2. With the engine idling, turn the pilot screw in or out to the setting that produces the highest idle rpm. The correct setting will usually be approximately 3 turns out (GXV120), 2-1/8 (GXV160) turns out from the fully closed position.

**CAUTION:** Do not tighten the pilot screw against its seat; this will damage the pilot screw or seat.

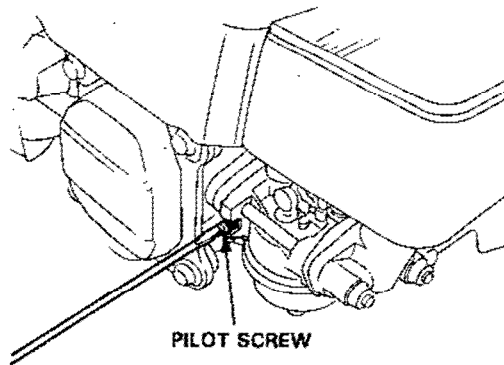

3. After the pilot screw is correctly adjusted, turn the throttle stop screw to obtain the standard idle speed.

**Standard idle speed: GXV120 2,000 ± 150 rpm.  
GXV160 1,700 ± 150 rpm.**

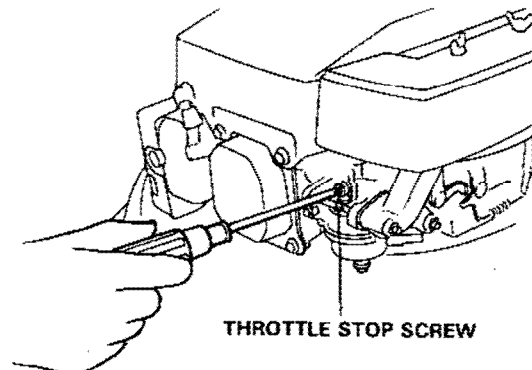

## 9. TRANSPORTING/STORAGE

---

**WARNING** When transporting the engine, turn the fuel valve to the OFF position and keep the engine level to prevent fuel spillage. Fuel vapor or spilled fuel may ignite.

Before storing the unit for an extended period;

1. Be sure the storage area is free of excessive humidity and dust.
2. Drain the fuel tank and carburetor into a suitable gasoline container:
  - a. Remove the fuel tube and drain the fuel tank.
  - b. Loosen the carburetor drain bolt to drain the carburetor.

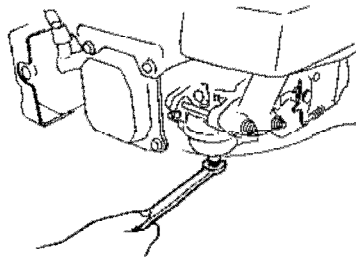

- c. Retighten the drain bolt, connect the fuel tube and turn the fuel valve OFF.

**WARNING** Gasoline is extremely flammable and is explosive under certain conditions. Do not smoke or allow flames or sparks in the area.

3. Change the engine oil (page 16).
4. Remove the spark plug and pour about a tablespoon of clean engine oil into the cylinder. Crank the engine several revolutions to distribute the oil, then reinstall the spark plug.
5. Pull the starter rope slowly until resistance is felt. This closes the valves and will help to protect the engine from internal corrosion.

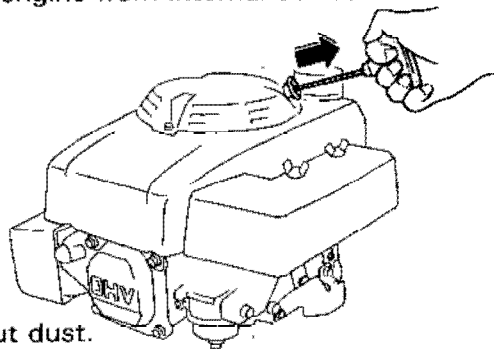

6. Cover the engine to keep out dust.

## 10. TROUBLESHOOTING

Engine will not start using recoil starter:

1. Is the control lever in the CHOKE position?
2. Is the fuel valve ON?
3. Is there fuel in the fuel tank?
4. Is gasoline reaching the carburetor?

To check, loosen the drain screw with the fuel valve on.

**WARNING** If any fuel is spilled, make sure the area is dry before testing the spark plug or starting the engine. Fuel vapor or spilled fuel may ignite.

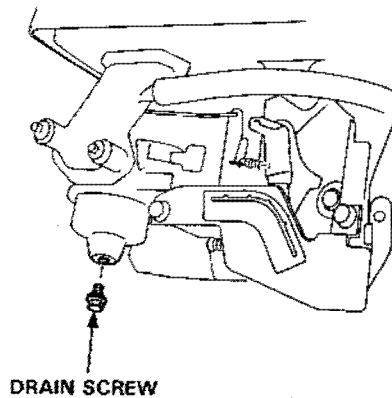

5. Is there a spark at the spark plug?
  - a. Remove the spark plug cap. Clean any dirt from around the spark plug base, then remove the spark plug.
  - b. Install the spark plug in the plug cap.
  - c. Turn the engine switch on.
  - d. Grounding the side electrode to any engine ground, and pull the recoil starter to see if sparks jump across the gap.
  - e. If there is no spark, replace the plug.  
If OK, reinstall the spark plug and try to start the engine again according to the instructions.
6. If the engine still does not start, take the engine to an authorized Honda dealer.

---

Engine will not start using electric starter:

1. Are the battery cables securely connected and free of corrosion?
2. Is the battery fully charged?
3. If the starter motor operates but the engine will not start, follow the troubleshooting procedures described under recoil starter operation.

## 11. SPECIFICATIONS

Dimensions	GXV120A <sub>1</sub>	GXV120D <sub>1</sub>
Length x Width x Height	375 x 355 x 335 mm (14.8 x 14.0 x 13.2 in)	←
Dry weight	12.1 kg (26.7 lb)	12.6 kg (27.8 lb)

### Engine

Engine type	4-stroke, overhead valve, single cylinder
Displacement [Bore x Stroke]	118 cc (7.2 cu in) [60 x 42 mm (2.4 x 1.7 in)]
Max. output	4.0 HP/3,600 rpm
Max. torque	0.82 kg-m (5.93 ft-lb)/2,700 rpm
Fuel consumption	250 g/HPh (0.55 lb/HPh)
Cooling system	Forced air
Ignition system	Transistorized magneto
PTO shaft rotation	Counterclockwise

Dimensions	GXV160
Power equipment description code	GJ03
Length x Width x Height	435 x 345 x 355 mm (17.1 x 13.6 x 14.0 in)
Dry weight	15.5 kg (34.17 lb)

### Engine

Engine type	4-stroke, overhead valve, single cylinder
Displacement [Bore x Stroke]	163 cc (9.9 cu in) [68 x 45 mm (2.7 x 1.8 in)]
Max. output	5.5 HP/3,600 rpm
Max. torque	1.1 kg-m (7.96 ft-lb)/2,500 rpm
Fuel consumption	250 g/HPh (0.55 lb/HPh)
Cooling system	Forced air
Ignition system	Transistorized magneto
PTO shaft rotation	Counterclockwise

---

- **High altitude operation**

At high altitude, the standard carburetor air-fuel mixture will be excessively rich. Performance will decrease, and fuel consumption will increase.

High altitude performance can be improved by installing a smaller diameter main fuel jet in the carburetor and readjusting the pilot screw. If you always operate the engine at altitudes higher than 6,000 feet above sea level, have your authorized Honda Engine dealer perform these carburetor modifications.

Even with suitable carburetor jetting, engine horsepower will decrease approximately 3.5% for each 1,000 foot increase in altitude. The affect of altitude on horsepower will be greater than this if no carburetor modification is made.

**CAUTION:** Operation of the engine at an altitude lower than the carburetor is jetted for may result in reduced performance, overheating, and serious engine damage caused by an excessively lean air/fuel mixture.

## 12. WARRANTY SERVICE

---

### Owner Satisfaction

Your satisfaction and goodwill are important to your dealer and to us. All Honda warranty details are explained in the Distributor's Limited Warranty. Warranty service is available at any dealership displaying the Honda Power Equipment Engines sign. To locate dealers in your area, look in the yellow pages of your telephone directory under Gasoline Engines, Garden & Lawn Equipment & Supplies, Lawn Mowers, etc.

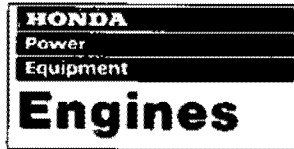

Normally, any problem concerning the engine will be handled by the dealer's service department. If you have a warranty problem that has not been handled to your satisfaction, we suggest you take the following action:

- Discuss your problem with a member of dealership management. Often complaints can be quickly resolved at that level. If the problem has already been reviewed with the Service Manager, contact the owner of the dealership or the General Manager.
- If your problem still has not been resolved to your satisfaction, contact the Power Equipment Customer Relations Department of American Honda Motor Co., Inc.

American Honda Motor Co., Inc.  
Power Equipment Customer Relations Department  
P.O. Box 50  
Gardena, California 90247-0805  
Telephone: (213) 604-2400

We still need the following information in order to assist you:

- Your name, address, and telephone number
- Engine model and serial number
- Date of purchase
- Dealer name and address
- Product or equipment in which the engine is installed.
- Nature of the problem

After reviewing all the facts involved, you will be advised of what action can be taken. Please bear in mind that your problem will likely be resolved at the dealership, using the dealer's facilities, equipment, and personnel, so it is very important that your initial contact be with the dealer.

Your purchase of a Honda engine is greatly appreciated by both your dealer and American Honda Motor Co., Inc. We want to assist you in every way possible to assure your complete satisfaction with your purchase.

## **Current customer service contact information:**

Servicing dealership personnel are trained professionals. They should be able to answer any question you may have. If you encounter a problem that your dealer does not solve to your satisfaction, please discuss it with the dealership's management. The Service Manager, General Manager, or Owner can help. Almost all problems are solved in this way.

### **United States, Puerto Rico, and U.S. Virgin Islands:**

If you are dissatisfied with the decision made by the dealership's management, contact the Honda Regional Engine Distributor for your area ([www.honda-engines.com/dea.htm](http://www.honda-engines.com/dea.htm)).

If you are still dissatisfied after speaking with the Regional Engine Distributor, you may contact the Honda Office as shown.

American Honda Motor Co., Inc.  
Power Equipment Division  
Customer Relations Office  
4900 Marconi Drive  
Alpharetta, GA 30005-8847

Or telephone: (770) 497-6400 M-F, 8:30 am - 7:00 pm EST

When you write or call, please provide the following information:

- Equipment manufacturer's name and model number that the engine is mounted on
- Engine model, serial number, and type
- Name of the dealer who sold the engine to you
- Name, address, and contact person of the dealer who services your engine
- Date of purchase
- Your name, address, and telephone number
- A detailed description of the problem





**HONDA**  
HONDA MOTOR CO., LTD. TOKYO, JAPAN

31ZE6030  
00X31-ZE6-0300

Ⓐ Ⓑ Ⓒ 5108811  
PRINTED IN JAPAN