



THE LIFTING EXPERTS

(800) 878-7305

www.RentLGH.com

Rentals@RentLGH.com

Digital Load Links | 110,000 - 330,000 Lbs. | WN Series | Wireless Compression Load Cell

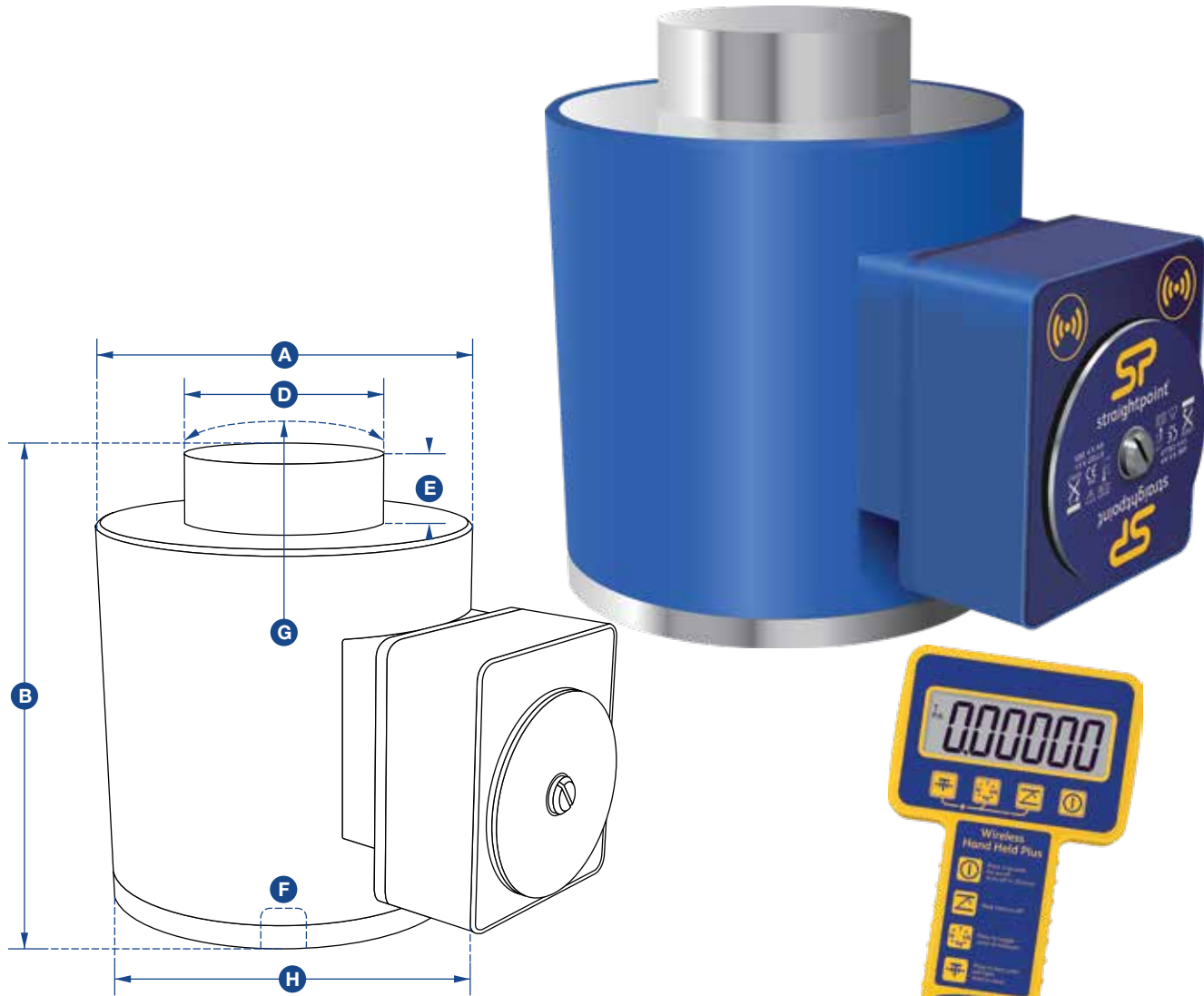

Dimensions							
Model	A	B	D	E	F	G	H
WN150TCU	4.02	5.00	2.32	0.51	M20 x 2.5	5.98	6.22
WN1150TCU	5.98	7.24	3.15	1.02	M20 x 2.5	17.01	8.19

Green shading reflects rental inventory.

Note: Requires the use of a wireless handheld display or wireless software package

Straightpoint WN150TCU													
Model	Capacity	Resolution	Units	Weight	Safety Factor	Battery Type	Battery Life	Operating Temp	Accuracy	Frequency	System Range	Data Rate	Protection
WN150TCU	110,000	20	lb	13.64	3:1	Load cell 4 x AA Alkaline	Load cell 1200 hrs continuous	14 F to 122 F	± 0.3% of applied load	2.4Ghz	2300 feet	3 Hz (Configurable to 200 Hz)	IP67 / NEMA 6
WN1150TCU	330,000	100	lb	34									

Green shading reflects rental inventory.





THE LIFTING EXPERTS

(800) 878-7305

www.RentLGH.com

Rentals@RentLGH.com

Digital Load Links | 110,000 - 330,000 Lbs. | WN Series | Wireless Compression Load Cell

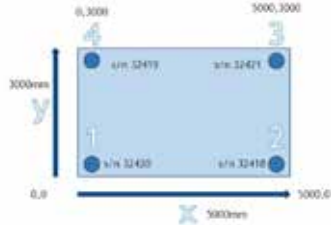

Now you will get read-outs of the load placed on each load cell, total weight, as well as a display of the center of gravity. The larger the circle the larger the weight.

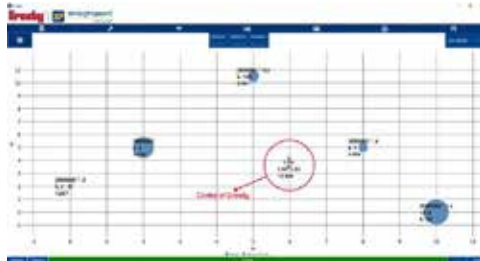

- SAFETY
- RELIABILITY
- INNOVATION

Cell Position	Cell Description	X	Y	Cell Position	Description	Weighting 1	Weighting 2	Weighting 3	Weighting 4
1	12420	0	0	1	12420	23.9	23.9	23.9	23.9
2	12420	0	0	2	12420	23.9	23.9	23.9	23.9
3	12420	0	0	3	12420	23.9	23.9	23.9	23.9
4	12420	0	0	4	12420	23.9	23.9	23.9	23.9
TOTAL						95.6	95.6	95.6	95.6

Insight Software

Insight has four main features:

- Multi-channel display and data logging mode - View and log load data from connected load cells plus totals loads live on screen and directly into a .csv file for later analysis at speeds of up to 200Hz.
- Centre of gravity mode - Connect to SP's range of wireless compression load cells and use this feature to weigh and calculate the center of gravity of large items and structures.
- Proof load testing - Real time graphing of load test and auto generated test certificates.

Features and Benefits:

- Logging at timed intervals, manual or on overload/underload
- Visual and audible alarms indicate overload, underload, low battery, and communications error
- 100% wireless, no easily damaged cables
- 700m or 2300ft range allows operator to stand at safe distance from test
- Connects to any Straightpoint wireless load cell
- Real-time load vs time graph display
- Three weighing's per C of G report with averages and statistical analysis to ISO19901
- Plot load cell positioning using measurements or GPS co-ordinates
- Free extra entry fields for operator, client, wind speed, sea states and temperature available for reporting

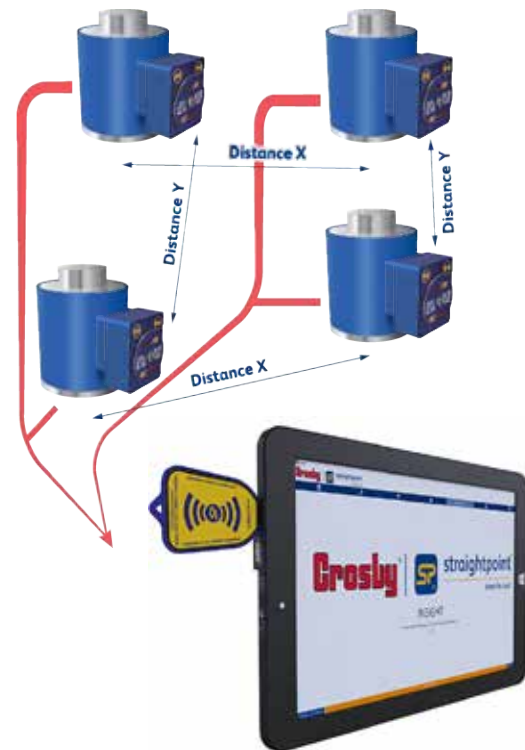

Straightpoint Insight								
Model	IP Rating (SW-USBSE)	Operating Temperature	License	Frequency	Range	Loadcell Inputs	PC Requirements	Operating System
Insight	IP65 or NEMA 4X	-20C to +70C or -4F to 158F	License Free	2.4GHz	700 meters / 2300 ft	Up to 126	Intel i3 processor with 2GB RAM	Windows 10 + 11

Green shading reflects rental inventory.

