

## Telescopic Spreader Beams | 25 - 75 Ton | Spreader Lifting Beam

AD32000A-1PA  
Telescopic Spreader, 23'-40'

- WLL: 25 Tons (50,000 Lbs.)
- Proof-tested and certified to 125% (62,500 Lbs.)
- Designed and manufactured to meet or exceed ASME B30.20
- Calculated weight: 1,825 Lbs.

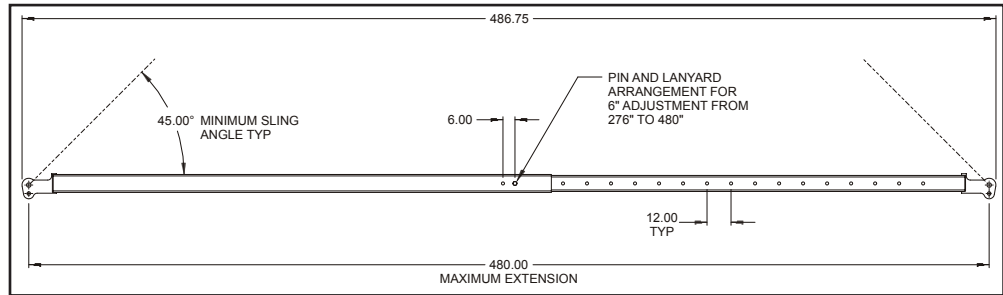

AA19000A-1PA  
Telescopic Spreader, 10.5'-18'

- WLL: 30 Tons (60,000 Lbs.)
- Proof-tested and certified to 125% (75,000 Lbs.)
- Standard specification #EA-D21000A applies.
- Designed and manufactured to meet or exceed ASME B30.20 and BTH-1, design category B, service class 0.
- Calculated weight: 560 Lbs.

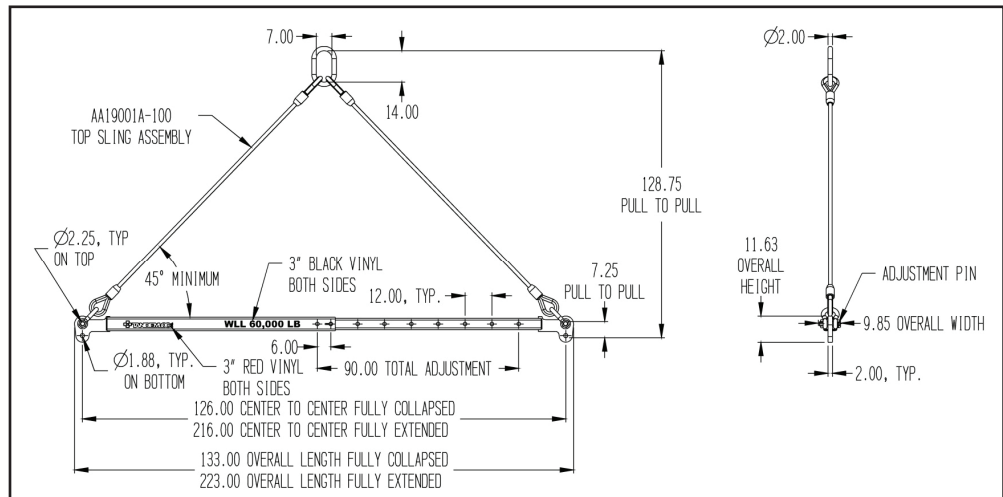

## Telescopic Spreader Beams | 25 - 75 Ton | Spreader Lifting Beam

### AA12000A-1PA

Telescopic Spreader, 15'-24'

- WLL: 75 Tons (150,000 Lbs.)
- Proof-tested to 125% (187,500 Lbs.) and certified (per OSHA 2232)
- Standard specification #EAD21000A applies.
- Designed and manufactured to meet or exceed ASME B30.20 and BTH-1, design category B, service class 0.
- Calculated weight: 1,650 Lbs.

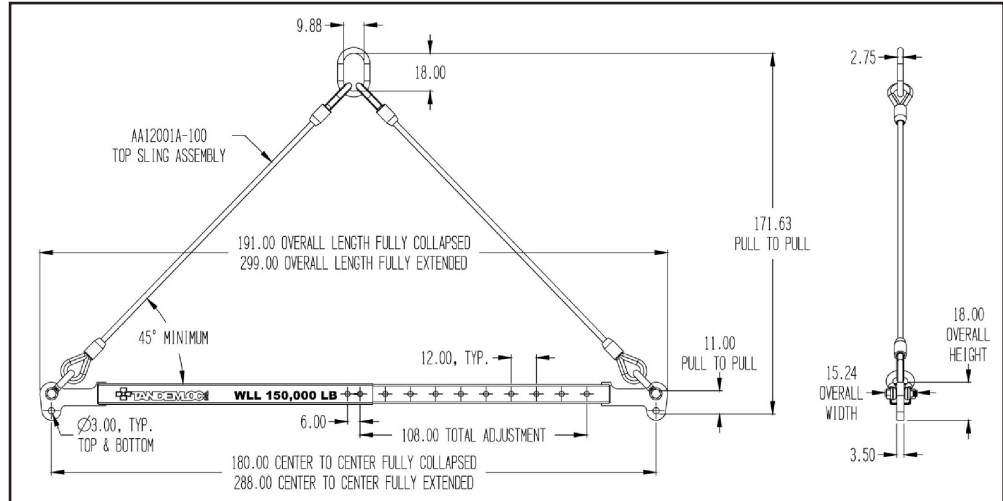

### AT14A060-216PA

Telescopic Spreader, 11'-18'

- WLL: 60,000 Lbs
- Proof-tested to 125% (75,000 Lbs.) and certified (per OSHA 2232)
- Standard specification #EAD21000A applies.
- Designed and manufactured to meet or exceed ASME B30.20 and BTH-1, design category B, service class 0.
- Calculated weight: 1,160 Lbs.

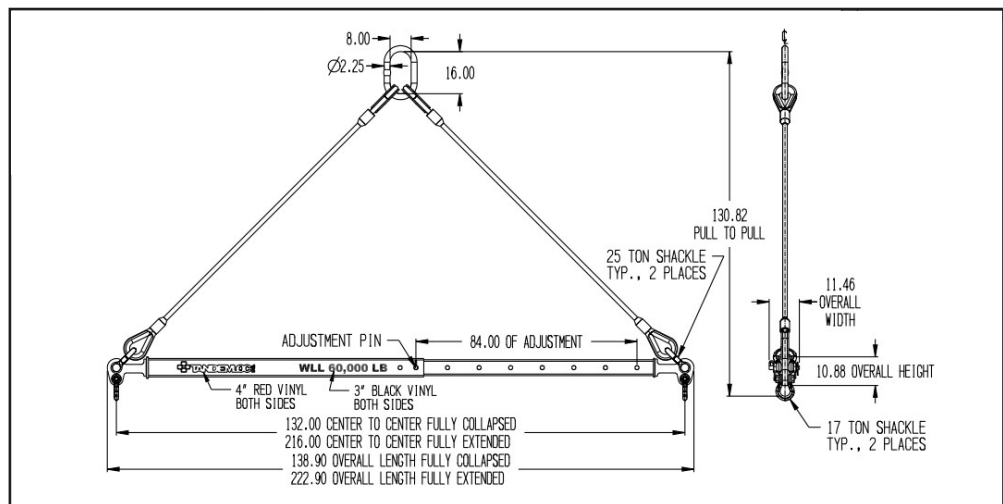

### Specifications

Model	Capacity (ton)	Weight (lbs.)	Min Length (ft.)	Max Length (ft.)
AD32000A-1PA	25	1825	23	40
AA19000A-0S-1PA	30	560	10.5	18
AA12000A-0S-1PA	75	1650	15	24
AT14A060-216PA	30	1160	11	18

Green shading reflects rental inventory.

